

STANDARD SPECIFICATIONS AND DETAILS FOR  
PUBLIC WORKS CONSTRUCTION



DEPARTMENT OF PUBLIC WORKS  
TOWN OF DENTON, MARYLAND

**REVISED MAY 2023**

---

Mark A. Chandler  
Superintendent of Public Works

---

Scott W. Getchell, PO  
Town Administrator

**TOWN OF DENTON  
DEPARTMENT OF PUBLIC WORKS**

**STANDARD SPECIFICATIONS AND DETAILS  
FOR  
PUBLIC WORKS CONSTRUCTION**

**TABLE OF CONTENTS**

<b>TITLE</b>	<b>PAGE</b>
<b><u>GENERAL PROVISIONS</u></b>	
Purpose .....	GP-1
Definitions.....	GP-1 thru GP-2
Abbreviations.....	GP-3
General Conditions.....	GP-4
<b><u>CONSTRUCTION SPECIFICATIONS</u></b>	
<b>Sanitary Sewer System</b>	
Section 1 - Excavation, Backfill & Surface Restoration .....	1-1 thru 1-17
Section 2 - Sanitary Sewers and Appurtenances .....	2-1 thru 2-10
Section 3 - Sewer House Laterals and Appurtenances .....	3-1 thru 3-3
Section 4 - Sanitary Sewer Manholes and Cleanouts .....	4-1 thru 4-5
Section 5 - Precast Concrete Grease Trap.....	5-1 thru 5-2
Section 6 - Force Mains and Appurtenances.....	6-1 thru 6-5
<b>Water System</b>	
Section 7 - Water Mains and Appurtenances .....	7-1 thru 7-8
Section 8 - Water House Services and Appurtenances.....	8-1 thru 8-3
<b>Storm Drains</b>	
Section 9 - Storm Drains and Appurtenances .....	9-1 thru 9-3
Section 10 - Storm Drain Manholes and Catch Basins.....	10-1 thru 10-5
<b>Streets</b>	
Section 11 - Concrete Curb, Gutter, and Sidewalk.....	11-1 thru 11-6
Section 12 - Preparation of Roadway Base.....	12-1 thru 12-3
Section 13 - Bituminous Concrete Pavement and Bituminous Surface Treatment.....	13-1 thru 13-2
Section 14 - Miscellaneous.....	14-1 thru 14-4

## DETAIL SHEETS

TITLE	PAGE
<b><u>GENERAL DETAILS</u></b>	
Barricade .....	G-1.00
Decorative Street Light Pedestrian Scale Height.....	G-2.00
<b><u>STANDARD SANITARY SEWER DETAILS</u></b>	
Pipe Bedding and Backfill Detail.....	SS-1.00
Precast Concrete Manhole .....	SS-2.00
Precast Concrete Inside Drop Manhole.....	SS-2.10
Shallow Precast Manhole .....	SS-2.20
Alternate Manhole Base (Doghouse manhole) .....	SS-2.30
Manhole Flow Channel .....	SS-2.40
Manhole Frame and Cover.....	SS-2.50
Manhole Inserts .....	SS-2.60
Mainline Cleanout.....	SS-3.00
Watertight Mainline Cleanout Frame and Cover .....	SS-3.10
Standard House Connections Shallow Main .....	SS-4.00
Standard House Connections Deep Main .....	SS-4.10
House Connection .....	SS-5.00
Lateral Cleanout for Grass Areas .....	SS-5.10
Lateral Cleanout for Traffic Areas.....	SS-5.20
Heavy Duty Cleanout Frame and Cover.....	SS-6.00
PVC Force Main Installation .....	SS-7.00
Force Main Discharge Manhole.....	SS-7.10
Air Release Valve .....	SS-7.20
Grease Trap .....	SS-8.00
<b><u>STANDARD WATER MAIN DETAILS</u></b>	
PVC Water Main Installation and Cover .....	W-1.00
Standard 1" Water Meter and 1 1/2" Service Connection .....	W-2.00
Dual Water Meter and 1 1/2" Service Connection .....	W-3.00
Double Meter Service Installation (Irrigation/Domestic).....	W-3.10
Water Meter and 1 1/2" Service Connection.....	W-4.00
Water Meter and 2" Service Connection.....	W-4.10
Typical Fire Hydrant Installation .....	W-5.00
Buttress for Upper Vertical Bends .....	W-6.00
Buttress for Tees, Plugs, & Caps.....	W-6.10
2" Blowoff Assembly .....	W-7.00

## **STANDARD STORM DRAIN DETAILS**

Precast Concrete Manhole .....	SD-1.00
Shallow Precast Manhole .....	SD-1.10
Standard "NR" Inlet .....	SD-2.00
Standard "WR" Inlet.....	SD-2.10
Pine Bedding & Backfill .....	SD-3.00

## **PAVEMENT AND CONCRETE DETAILS**

Collector Streets Residential Areas .....	PW-1.00
Minor Streets in Single Family Residential Areas .....	PW-1.10
Cul-de-Sac in Single Family Residential Areas .....	PW-1.20
Residential Alley .....	PW-1.30
Collector Streets Commercial & Industrial Areas.....	PW-1.40
Standard Roadway Cross-Section-Minor Collector .....	PW-1.50
Standard Roadway Cross-Section-Local Access .....	PW-1.60
Combination Concrete Curb & Gutter.....	PW-2.00
Valley Gutter and Intersectional Detail .....	PW-3.00
Typical Driveway Entrance with Grass Strip .....	PW-4.00
Typical Driveway Entrance Without Grass Strip .....	PW-4.10
Typical Sidewalks .....	PW-5.00
Typical Curb, Gutter, & Sidewalk Expansion Joints.....	PW-5.10
Handicap Ramp.....	PW-6.00
Handicap Ramp with Grass Strip.....	PW-6.10
Pavement Restoration .....	PW-7.00
Street Name Sign .....	PW-8.00
Vehicle Accommodation Area Surfaces .....	PW-9.00

## **GENERAL PROVISIONS**

### **PURPOSE**

The Purpose of these "Standard Specifications and Details for Public Works Construction" is to set forth the requirements of the Town of Denton, Maryland, Department of Public Works for the construction, renovation, or replacement of streets, water, sewage, and storm drainage facilities.

### **DEFINITIONS**

Wherever used in these specifications, the following terms shall have the meanings indicated which shall be applicable to both the singular and plural thereof:

1. Collector Street - A street which is intended to collect traffic from the minor streets within a neighborhood or a portion thereof and to distribute such traffic to major thoroughfares, in addition to providing access to properties abutting thereon.
2. Cul-de-sac - A minor street having but one end open for vehicular traffic and with the other end permanently terminated by a turnaround or backaround for vehicles.
3. Contract Documents - The contract, including Advertisement for Bids, Information for Bidders, Bid, Bid Bond, Agreement, Payment Bond, Performance Bond, Notice of Award, Notice to Proceed, Change Order, Drawings, Specifications, and Addenda.
4. Contractor - The individual or entity responsible for performing and completing the construction of a project required by the Contract Documents.
5. Drawings - The part of the Contract Documents which show the characteristics and scope of the work to be performed and which have been prepared or approved by the Engineer.
6. Engineer - Person or organization professionally qualified and duly licensed to perform architectural or engineering services; which may include but not necessarily be limited to development of project requirements; creation and development of project design; preparation of drawings, specifications, and bidding requirements; and providing of services during the construction and start-up phases of the project.

7. Maryland State Highway Administration Specifications - The Maryland Department of Transportation State Highway Administration Standard Specifications for Construction and Materials July 2020.
8. Minor Street - A street other than a major thoroughfare or collector street and intended primarily for providing access to abutting properties.
9. Owner - The Mayor and Town Council of the Town of Denton, Maryland or individual or group for whom the work is to be performed.
10. Resident Project Representative - The authorized representative of the Owner who administers the construction contract and monitors progress and relationships among the project site personnel.
11. Service Drive - A minor street which is parallel to and adjacent to a major thoroughfare, and which provides access to abutting properties and restricts access to the major thoroughfare.
12. Shop Drawings - All drawings, diagrams, illustrations, brochures, schedules and other data which are prepared by the Contractor, a Subcontractor, manufacturer, Supplier or distributor, which illustrate how specific portions of the work shall be fabricated or installed.
13. Specifications - A part of the Contract Documents consisting of written descriptions of a technical nature or materials, equipment, construction systems, standards and workmanship.
14. Subcontractor - An individual, firm or corporation having a direct contract with the Contractor or with any other subcontractor for the performance of a part of the work at the site.
15. Supplier - Any person or organization who supplies materials or equipment for the work, including that fabricated to a special design, but who does not perform labor at the site.
16. Work - All labor necessary to produce the construction required by the Construction Documents, and all materials and equipment incorporated or to be incorporated into the project.
17. Where "as shown", "as indicated", "as detailed", or words of similar import are used, it is understood that reference to the drawings accompanying this specification is made unless stated otherwise.
18. Where "as directed", "as required", "as selected", "permitted", "acceptance", or words of similar import are used, it is understood that direction, requirement,

selection, permission or acceptance by the Engineer and compliance with codes and regulations are intended unless stated otherwise.

19. Where used, "provide" is understood to mean "provide complete in place"; that is, "furnished and installed."
20. Where "items of material, equipment, work, etc.," and "methods of installation, finish, and accomplishment, etc." are referred to in this specification it is understood to refer to all such "items, materials, equipment, work, finish, etc."
21. Where "includes" is used, it understood to mean "includes, but is not limited to."
22. Where "equal to", "or equal", or "approved equal", are used, the Contractor may substitute a product or material, which in the judgment of the Engineer, expressed in writing, is equal to that specified.

### **ABBREVIATIONS**

Where used in these specifications or on details, the following abbreviations shall have the meanings indicated below:

AASHTO	American Association of State Highway and Transportation Officials
ANSI	American National Standards Institute
ASTM	American Society of Testing and Materials
AWWA	American Water Works Association
CL	Class
CTS	Copper Tube Size
DI	Ductile Iron
FIP	Female Iron Pipe
GAB	Graded Aggregate Base
HDPE	High Density Polyethylene
IPS	Iron Pipe Size
LF	Lineal Feet
MDE	Maryland Department of Environment
MDOT SHA	Maryland Department of Transportation State Highway Administration
MIP	Male Iron Pipe
MJ	Mechanical Joint
OSHA	Occupational Safety and Health Administration
P/J	Pack Joint
PEP	Polyethylene Pipe
PSI	Pounds per Square Inch
PVC	Polyvinyl Chloride
ROW	Right-Of-Way
SDR	Standard Dimension Ratio

## **GENERAL CONDITIONS**

The Specifications and Details contained herein are intended to provide requirements for all public works construction undertaken within the Town of Denton. These Specifications and Details are consistent with existing Town of Denton standards, policies, and regulations. In addition to the requirements contained herein, all public works construction shall be in accordance with the most current edition of the following documents.

1. Town of Denton Critical Area Program
2. Comprehensive Plan
3. Land Subdivision Regulations
4. Zoning Ordinance
5. Forest Conservation Ordinance

All construction shall be in accordance with applicable county, state and federal requirements including but not limited to Sediment and Erosion control and Stormwater Management, Maryland Department of Transportation State Highway Administration, Maryland Department of the Environment and U.S. Army Corp of Engineers requirements. In the event of a conflict between the standards and details contained herein and applicable county, state, or federal requirements, the conflict shall be resolved in favor of the stricter requirement.

Upon completion of construction of the public works facilities and final approval thereof by the Town of Denton, right, title and interest in and to said facilities shall be conveyed to the Town of Denton free and clear of any and all liens, claims, charges and encumbrances attaching thereto. Said transfer of the right, title, and interest in and to said facilities shall be accomplished by such documentation as the Town attorney shall deem necessary and appropriate.

Where any article or material is specified by proprietary name, trade name, and/or manufacturer's name, with or without the addition of such expressions as "or equal", or "approved equal", it is to be understood that the article named or the equal thereof, is intended, subject to the approval of the Engineer. It is distinctly understood that; (1) The Engineer is to use his/her own judgment in determining from time to time whether or not any article or material proposed to be substituted is the equal of any article or thing specified; (2) The decision of the Engineer on all such questions or equality shall be final; (3) In the event of any adverse decision by the Engineer no claim of any sort shall be made or allowed against the Engineer or the Owner.

Design parameters for water and sewer utilities shall be in accordance with the latest editions of the Ten State Standards and Maryland Department of the Environment Design Guidelines.

**END OF SECTION**



## **SECTION 1**

### **EXCAVATION, BACKFILL & SURFACE RESTORATION**

#### **1. GENERAL**

A. The Contractor shall excavate, protect, and backfill all excavations that may be necessary for completing the work to be done under the contract. Excavations shall be open cut except where and to such extent as the Engineer or permit requirements may authorize or direct that the same be done by other methods. Trenches may in general be excavated and backfilled either by machinery or by hand as the Contractor may elect provided, however, that the Engineer shall be empowered, wherever he shall decide that such necessity exists, to direct that hand excavation shall be employed, and provided further that backfilling by hand shall be done to the extent hereinafter specified. The Contractor shall have no claim for extra compensation due to the fact that hand instead of machine excavation may be required at any location where necessary from any cause whatever.

B. All excavation under this contract is unclassified; that is, the prices bid for furnishing and laying pipe shall be taken to include and cover all materials required to be excavated and backfilled, whether wet or dry, and regardless of the character of the materials. The excavations, removal and replacement of road surfacing materials, curb, sidewalk, and gutter, as required, shall be included in the unit prices bid for furnishing and laying pipe with any exceptions as noted herein or as designated on the plans.

C. In all areas which the Maryland Department of Transportation State Highway Administration exercises jurisdiction, all excavation and backfill shall be accomplished in full conformance with their requirements.

#### **2. REMOVAL AND STORAGE OF SURFACE AND SUBGRADE MATERIALS**

A. The Contractor shall grub and clear the surface and remove all surface and subgrade materials of whatever nature over the line of the trench and the site of other structures and areas to be graded; and he shall properly store, guard, and preserve such of said materials as may be required for use in backfilling, resurfacing, repaving, or for any other purposes.

B. All curb, gutter, sidewalk, concrete traffic markers, brick and flagstones, and all paving material which may be removed for re-use together with all materials taken from trenches, shall be stored in such parts of the roadway or such other suitable places and in such manner as shall be approved or directed. The Contractor shall be responsible for any loss of or damage to curb, gutter, sidewalk, concrete traffic markers, brick, and

flagstones, and to paving material through their careless, or neglectful, or wasteful storage, disposal, or use.

C. Materials shall not be deposited or temporarily stockpiled on private property unless permission is obtained from the individual Owner(s) in writing and the acceptance of the Engineer is secured by the Contractor. Prior to completion and acceptance of the work, a written release shall be obtained from those property owners having accepted disposal materials absolving the Owner from any liability connected therewith. The Contractor shall provide the Engineer with copies of each release.

D. Stockpiled materials shall in no case be placed in such a manner as to endanger the trench, existing structures, private property, or the environmental quality of the area. Measures shall be taken to insure no blockage of existing surface drainage and to minimize the possibility of erosion and siltation of these materials.

E. All materials not suitable for incorporation in the finished work shall be disposed of by the Contractor at a location approved by the Engineer. The Contractor shall be responsible for obtaining a disposal site.

### 3. WIDTH AND DEPTH OF TRENCHES

A. Trenches shall be excavated to the necessary width as shown on applicable Town of Denton standard details or as described herein and to the necessary depth as shown on the drawings, or as directed.

<u>Pipe Dia.</u>	<u>Trench Width</u>
4" thru 24"	4'-0"
27" thru 30"	5'-0"

B. Where excavation is carried below specified subgrade elevations, or to a greater than detailed trench width, the Contractor shall, at no additional expense to the Owner unless specifically provided for by an approved contingency item associated with a bid proposal, make corrections to subgrade and width using approved backfill materials. Materials so used shall be thoroughly compacted to provide a firm and unyielding subgrade, acceptable to the Engineer.

C. The side of the trenches shall be supported or sheeted where required for safety, or as required by OSHA and/or State safety regulations.

### 4. LENGTH OF OPEN TRENCH

A. No greater length of trench in any location shall be left open in advance of the completed structure placed therein than shall be authorized or directed. The Engineer shall be empowered at any time to require the backfilling of open trenches over completed pipe lines if in his judgement such action is necessary, and the Contractor

shall thereby have no claim for extra compensation even though to accomplish said backfilling he is compelled temporarily to stop excavation or other work at any place.

B. If work is stopped on any trench for any reason and the excavation is left open in advance of construction, the Contractor shall, if so directed, backfill said trench at his own cost and shall not again open said trench until he is ready to complete the structure therein. If the Contractor shall refuse or fail to backfill said trench completely within 48 hours after said notice, the Owner shall be authorized to so do the work and the Owner shall charge the expense thereof to the Contractor and retain the same out of any monies due, or to become due, to him under the contract.

C. The excavation of all trenches shall be fully completed at least 20 feet in advance of pipe laying unless otherwise authorized.

## **5. EXCAVATION BELOW SUBGRADE**

A. Whenever the character of the material at the bottom of an excavation is such, in the opinion of the Engineer, as to require excavation to an additional depth for adequate foundation, or wherever a trench has been excavated by machinery to the grade directed by the Engineer and he deems it necessary on account of a change in plan to excavate deeper such additional depth shall be excavated by the Contractor as directed by the Engineer.

B. Except as modified above, subgrade in the case of pipe lines shall be termed the underside of the pipe foundation as shown on the plans. For miscellaneous structures, subgrade shall be termed the underside of the masonry slab, foundation or gravel bedding as shown on the plans, or as described in the specifications.

## **6. PREPARATION OF FOUNDATION**

A. The Contractor shall complete excavations in earth as nearly as practicable to the neat lines of the structures to be built therein. All irregularities and cavities in the bottoms of trenches shall be filled to the required level with clean earth, or other approved material firmly compacted before pipe lines are laid therein and without extra compensation unless said cavities have been formed at the direction of the Engineer.

B. As directed, the Contractor shall use suitable material from excavation, special backfill, gravel or concrete, or a combination thereof in backfilling excavations below subgrade. The Engineers opinion regarding suitability of excavated material for use in preparation of subgrade shall be final. In general, organic material, refuse, large lumps or stones having any dimensions greater than 2 inches, paving material, frozen earth, or materials which will not readily consolidate or compact in the trench will be considered unsuitable.

C. The requirements for dewatering pipe trenches include an obligation on the part of the Contractor to secure a dry trench bottom. If the Contractor elects to use gravel bedding to assist in drainage of trench bottom, he may do so to the extent approved by the Engineer.

## **7. DEWATERING**

A. Dewatering shall be accomplished by methods which shall insure that the groundwater will be drawn down to an elevation below the bottom of the bedding. Said methods may include deep wells, well points, and other means, subject to acceptance of the Engineer. Upon removal of such dewatering equipment, the Contractor shall backfill, consolidate and pave (in roads) all holes, including restoration of adjacent disturbed areas to pre-existing, or better, conditions.

B. Dewatering for structures and pipelines shall commence when groundwater is first encountered and shall be continued until such time as backfill operations have been completed.

C. The Contractor shall provide for the disposal of all water removed from excavations so that it will not cause injury to the public health, to public or private property, or to any portion of the work completed or in progress, or cause any impediment to the use of the streets by the public. Excessive local ponding and siltation, or its deposition will not be tolerated.

D. Dewatering operations in trenches adjacent to existing structures shall be accomplished in a manner which will exclude the possibility of earth material being washed from areas outside the confines of the trench structurally endangering existing structures.

E. Should the Contractor's dewatering operations affect any existing private water supply well used exclusively as a primary potable water source, the Contractor shall, at no additional cost to the Owner, take whatever steps are necessary to provide uninterrupted water service, including the installation of temporary water lines, if required.

F. The cost of dewatering and associated work shall be considered as incidental to other bid items and included in the prices bid for them.

G. It shall be the Contractor's responsibility to verify groundwater conditions prior to bidding. Should soil boring information provided as a part of the Contract Documents indicate no ground water present at the time they were prepared, this does not relieve the Contractor of his responsibility. The presence or absence of groundwater at the time of construction shall not entitle the Contractor to additional compensation.

## **8. SHEETING, SHORING AND/OR BRACING**

A. The Contractor shall support the sides and ends of all excavations, wherever necessary, with sheeting, shoring and/or bracing of the quality and character as required. All sheeting, shoring and/or bracing shall be put in place by men skilled in such work and shall be so arranged that it may be withdrawn, as backfilling proceeds, without injury to the structures built under the contract, or to any road bed or adjacent structure, or property.

B. All sheeting, shoring and/or bracing in excavations shall be withdrawn in stages on both sides of trenches (to prevent lateral movement of the pipe) as the backfilling is being done, except where and to such extent as the Engineer shall order in writing that said sheeting be left in place, or where he shall permit the same to be left in place at the Contractor's expense upon his request. The Contractor shall cut off any sheeting ordered left in place as directed and shall remove the material cut off without compensation therefore.

C. Wherever necessary in quicksand, or soft ground, or for the protection of any structure or property, sheeting shall be driven without extra compensation to such additional depth below the bottom of the trench as may be required or directed.

D. The cost of installing and removing sheeting will be included in the unit prices bid for furnishing and installing pipe.

E. A trench box may be used in lieu of sheeting, shoring and/or bracing only upon approval of appropriate Safety Agencies.

## **9. MISCELLANEOUS EXCAVATION**

A. The Contractor shall perform such miscellaneous excavation as may be necessary or directed. Such excavation shall be subject to the same conditions and requirements as specified for trench excavation.

B. Miscellaneous Excavation shall include the digging of test pits, extra width of trench made necessary by change in its location, or excavation for any special structures outside the trench that may not be shown on the drawings or described in the specifications, where such excavation is done at the direction of the Engineer.

C. Test pits shall be dug by the Contractor, whenever directed. The depth and size shall be such as required by the Engineer. Test pits shall be dug by the Contractor, without being directed to do so, along the lines of the trenches as shown on the drawings in advance of the excavation for the purpose of satisfying himself as to the location and elevation of underground obstructions or conditions.

## 10. BACKFILLING

A. The Contractor shall backfill all excavations as rapidly as practicable after the completion of construction work therein or after the excavations have served their purpose. All unauthorized excavations made by the Contractor shall be immediately backfilled. All backfilling shall be accomplished as specified herein and as indicated on applicable trench cross section details.

B. Materials from excavation shall be used for backfill unless, in the opinion of the Engineer, such material is not suitable for such use. In general, organic material, refuse, large lumps or stones having any dimension greater than 2-inches, paving material, frozen earth, or materials which will not readily consolidate or compact in the trench will be considered unsuitable. The Engineer's decision regarding suitability or unsuitability of materials shall be final.

C. Backfill materials shall be carefully placed and compacted along the haunch of the pipe. Unless otherwise indicated or directed, backfill materials shall be hand placed in 6-inch lifts to a point at least one foot above the pipe crown. Each layer shall be thoroughly compacted for the full trench width and under, around and over the pipe, using mechanical tampers exerting a pressure of not less than 250 foot-pounds per square foot of tamping force.

D. Unless otherwise indicated or directed, the remainder of trench, more than one foot above pipe crown, may be backfilled by machinery. In areas under MDOT SHA jurisdiction the trench will be backfilled in 8" layers. All other areas may be backfilled in 12" layers. Each layer shall be thoroughly compacted for the full trench width using mechanical tampers or other suitable equipment. Heavy duty equipment shall not be run over the trench unless pipe cover exceeds three (3) feet.

E. All backfill materials under roadways, driveways, or shoulder areas shall be compacted to 95% density. All other areas shall have backfill materials compacted to 90 percent of maximum density at optimum moisture content for the specific soil classification, as determined by the modified Proctor Test AASHTO T-180 Method A or ASTM D-1557. If the Engineer has reason to believe that proper compaction of trench backfill is not being obtained, he may direct that Proctor and field density testing be done to determine the degree of compaction. Such testing shall be arranged by the Contractor and performed by an independent testing agency approved by the Engineer. Whenever test results indicate compaction densities less than specified, the Contractor shall secure the specified compaction using methods approved by the Engineer. The testing agency, so employed by the Contractor, shall submit a copy of all testing reports directly to the Engineer. Each report shall contain the project identification name and number, name of Contractor, name of testing agency, and location of sample tested by station, street and depth, as a minimum.

F. After completion of backfilling, all material not used shall be removed and disposed of in such manner and at such point as shall be approved, or directed, and all roads, sidewalks, and other places on the line of the work shall be left free, clean and in good order. Said cleaning up shall be done by the Contractor, and if he shall fail to do such work within a reasonable time after receipt of notice, it will be performed by the Owner, and the cost shall be retained out of the monies due, or to become due, the Contractor under the contract.

G. Vibratory rollers may be used at the surface if approved by the Engineer. Variation in depth of fill layers will not be permitted because of the use of vibratory rollers.

H. No pipelines shall be backfilled until measurements of pipe, etc. have been made by the Engineer and until the Engineer's permission to backfill has been secured. Any pipelines covered without authorization shall, if required by the Engineer, be unearthed for any required inspections, measurements, or testing.

## **11. SPECIAL BACKFILL**

A. Should any excavated materials be considered by the Engineer to be unsatisfactory for backfill, the Contractor shall remove and dispose of such material at an approved location.

B. If sufficient approved material from excavation at other work locations is not available for backfill, the Contractor shall secure and place sufficient approved material from borrow to complete the backfill.

C. All requirements for placement, compaction, and field testing of backfill material shall apply as well to "Special Backfill."

E. The Contractor shall be required to submit a MDOT SHA approved source of supply for borrow materials at the pre-construction conference.

## **12. PRODUCTS**

A. Special Backfill: Material from borrow conforming to MDOT SHA Specification Section 916.01.

B. Gravel Bedding: Crushed stone or gravel meeting MDOT SHA Specification Section 901.01 for No. 57.

C. Misc. Concrete: 3000 psi concrete.

D. Crusher Run: Graded aggregates meeting, MDOT SHA Specification Section 901.01 for Graded Aggregate (GA) Base.

### **13. RESPONSIBILITY FOR CONDITION OF EXCAVATION**

A. The Contractor shall be responsible for the condition of all excavations made by him. All slides and caves shall be removed without extra compensation at whatever time and under whatever circumstances they occur.

B. The neglect, failure or refusal of the Engineer to order the use of bracing or sheeting of a better quality or larger size of timber, or to order sheeting, bracing, or shoring to be left in place, or the giving or failure to give order or directions as to the manner or methods of placing or driving sheeting, braces, or shores, shall not in any way or to any extent relieve the Contractor of any responsibility concerning the condition of excavations or of any of his obligations under the contract; nor shall any delay, whether caused by any action or want of action on the part of the Contractor or by any act or want of action of the Owner or his agents or employees resulting in the keeping of an excavation open longer than would otherwise have been necessary, relieve the Contractor from the necessity of properly and adequately protecting the excavation from caving or slipping or from any of his obligations under the contract relating to injury of person or property nor entitle him to any claim for extra compensation.

### **14. PROTECTION OF PROPERTY AND STRUCTURES**

A. The Contractor shall sustain in their places and protect from direct or indirect injury all pipes, wires, conduits, poles, tracks, walls, signs, wells, septic tanks, buildings, and other structures or property in the vicinity of his work whether above or below ground, or that may appear in the trench. He shall at all times have a sufficient quantity of timber and plank, chains, ropes, etc. on the site and shall use them as necessary for sheeting his excavations and for sustaining or supporting any structures that are uncovered, undermined, endangered, threatened, or weakened. The Contractor shall take all risks attending the presence or proximity of pipes, wires, conduits, poles, tracks, walls, buildings, and other structures and property of every kind and description in or over his trenches or in the vicinity of his work whether above or below the ground surface, and he shall be responsible for all damage and assume all expense for direct or indirect injury caused by his work to any of them or to any person or property by reason of injury to them, whether such structures are, or are not, shown on the drawings.

### **15. OBSTRUCTIONS SHOWN/NOT SHOWN ON DRAWINGS**

A. Certain information regarding the reputed presence, size, character, and location of existing underground and above ground structures have been shown on the plans. There is no certainty as to the accuracy of this information, and it shall be considered by the Contractor in this light. The locations and elevations of underground and/or above ground structures shown may be inaccurate, and obstructions other than those shown may be encountered. The Contractor shall hereby distinctly understand that the Owner



is not responsible for the correctness or sufficiency of the information given, or on account of the insufficiency or absence of information regarding obstructions either revealed, or not revealed by the drawings; and that he shall have no claim for relief from the obligation or responsibility under the contract in case the location, size or character of any pipe, wire, conduit, pole, sign or other underground and/or above ground structure is not as indicated on the drawings or in case any pipe, wire, conduit, pole, sign or other underground and/or above ground structure is encountered that is not shown on the drawings.

B. The Contractor shall locate, protect, change, remove, realign, relocate, replace, or repair all signs and overhead and underground obstructions, structures and utilities whether shown on the drawings or not, as necessary for construction of the project. The contractor shall contact "Miss Utility" prior to any excavation activities. The Contractor shall uncover and support such structures before such removal, and before and after such alignment or change, as a part of the contract; and the Contractor shall not be entitled to any claim for damage on account of the presence of said structure or on account of any delay in the removal or rearrangement of same. The Contractor shall break through and reconstruct if necessary the invert or arch of any sewer, culvert, or conduit that may be encountered if said structure is in such position as, in the judgment of the Engineer, does not require its removal, realignment, or complete reconstruction. The Contractor shall obtain the written permission of the property owner affected prior to the Contractor relocating, realigning and/or replacing any obstructions to construction owned by said affected property owner.

## **16. REMOVAL OF OBSTRUCTIONS**

A. Except for items specifically noted to be removed or relocated, if the position of any pipe, conduit, pole, or other structure above or below ground, and not shown on the plans, be such, in the opinion of the Engineer, as to require its removal, realignment, or change due to work to be done under the contract, the work or removal, realignment or change will be done as extra work, or will be done by the Owner of the obstructions without cost to the Contractor; but the Contractor shall uncover and support such structures before such removal, and before and after such alignment or change, as a part of the contract; and the Contractor shall not be entitled to any claim for damage on account of the presence of said structure or on account of any delay in the removal or rearrangement of same.

B. The Contractor shall not interfere with any persons, firms, or corporations or with the Owner in protecting, removing, changing or replacing their pipes, wires, conduits, poles, or other structures; but he shall suffer said persons, firms or corporations or the Owner to take all such measures as they may deem necessary or advisable for the purpose aforesaid; and the Contractor shall thereby be in no way relieved of any of his responsibilities under the contract.

## **17. CHANGE OF TRENCH LOCATION**

A. In case the Engineer shall direct that the location of a trench be changed to a reasonable extent from that shown on the plans on account of the presence of an obstruction or from other cause or if a changed location shall be authorized upon the Contractor's request, the Contractor shall not be entitled to extra compensation or to a claim for damage provided that the change is made before the excavation is begun. If, however, such change, made at the direction of the Engineer, involved the abandonment of excavation already made, such abandoned excavation together with the necessary refill will be classed as "Miscellaneous Excavation and Backfill". In the event that the trench is abandoned in favor of a new location at the Contractor's request, the abandoned excavation and refill shall be at the Contractor's expense.

B. If an obstruction shall lie within the trench in such manner that the trench has to be excavated to extra width in order that sheeting, shoring and/or bracing may be properly placed or in order that the structure to be placed in the trench may be properly built, such extra width of trench shall be classed as "Miscellaneous Excavation and Backfill". No sloping of sides of excavations, however, will be considered as miscellaneous excavation.

## **18. MATERIAL EXCAVATED NOT THE PROPERTY OF CONTRACTOR**

A. The Contractor shall have no property right to any material taken from any excavations, and shall not remove any earth, sand, or other material from the site of the work, except upon direction or written permission of the Engineer, or as hereinbefore specified.

B. The Contractor shall not be relieved by the above provisions of any of his obligations to remove and dispose of materials excavated, with or without rehandling, as elsewhere herein provided.

## **19. MAINTENANCE OF BACKFILLED EXCAVATIONS**

A. The Contractor shall maintain at his own expense all back-filled, repaved, topsoiled or otherwise restored areas in proper condition until the end of the guarantee period for the project. All defects shall be promptly corrected. If the Contractor shall fail to do so within a reasonable time after the receipt of written notice from the Engineer, the Engineer may remedy such defects and the cost thereof shall be deducted from any monies due or to become due the Contractor under the contract. In case of emergency, the Engineer may correct any dangerous condition without giving previous notice to the Contractor; and the cost of so doing shall be retained from any monies due the Contractor.

B. The Contractor shall be responsible for any injury or damage that may result from improper maintenance of trenches or pavement at any time prior to the end of the aforementioned guarantee period.

## **20. ACCOMMODATION OF TRAFFIC**

A. Any restriction or diversion of traffic at any time shall be subject to the approval of the Engineer and the requirements of that agency having jurisdiction over the road in which the Contractor is working.

B. During the progress of the work, sidewalks and crossings shall be kept open for the passage of pedestrians unless otherwise authorized. Streets shall not be unnecessarily obstructed; and unless the Engineer, MDOT SHA and/or Town of Denton as applicable, shall authorize the complete closing of a street, the Contractor shall take such measures at his own expense as may be necessary to keep the street open for traffic. This shall include but not necessarily be limited to the provision, erection and maintenance of all necessary signs, barricades, lights and flagmen or uniformed traffic directors.

C. The Contractor shall construct and maintain without extra compensation such adequate and proper bridges over excavations as may be necessary or directed for purpose of accommodating pedestrian and/or motor vehicles.

D. Construction activities which may temporarily interfere with property access shall be coordinated in advance with the individual property owners.

E. Access to fire hydrants shall be possible at all times and, wherever possible, one lane of traffic shall be maintained to accommodate access by emergency vehicles.

F. If full road closure is authorized, contractor shall make notice, in advance, to all local emergency service agencies including, but not limited to, police, fire, and ambulance departments.

## **21. ACCOMMODATION OF DRAINAGE**

A. Gutters and drains shall be kept open at all times for surface drainage. No damming or ponding of water in gutters or other waterways will be permitted, except to a limited extent where the Engineer shall consider the same necessary or allowable.

B. The Contractor shall be responsible for all necessary diversions of drainage flows and erosion and sediment control measures associated therewith.

## 22. SURFACE RESTORATION

### A. Paving

1. The Contractor shall be required to repave over all excavations made by him in paved areas, for the full width of the disturbed area and for additional width as may be required to secure a satisfactory juncture with undamaged pavement. This requirement includes trimming back existing pavement to secure an even and clean edge for repaving by use of milling machinery or other approved methods.
2. The Contractor shall remove existing paving for such width as is necessary for repaving. If he removes paving for a greater width than is specified or required, or if paving is removed or disturbed due to settlement, or slides, or non-authorized excavation, he shall replace same for the full extent of removal without extra compensation, therefore.
3. The Contractor shall permanently repair or relay all curbs, gutters, sidewalks, driveways, and appurtenances, etc. that have been removed, broken, or otherwise injured in executing any of the work under the contract or by or on account of said work on account of settlement of any refilled excavation at any time prior to the termination of the contract. Said curbs, gutters, sidewalks, driveways, etc. shall be restored to a condition similar and equal to that existing before the damage was done. No patching of squares of cement pavement will be allowed, but whole new square shall be laid in place of any that have been damaged. Curb and gutter replacement shall be made in entire sections with no patching permitted.
4. If the Contractor shall fail or neglect to perform such relaying or repairing of paving, surfacing, roadway curbs, gutters, sidewalks, driveways, and appurtenances, etc. in a proper manner or make provisions for having said work done, the Engineer shall after due notice perform said work or make provisions for performing it; and the Owner shall retain the expense thereof out of any monies due or to become due the Contractor under the Contract.
5. The Contractor shall construct temporary bituminous paving or a stabilized gravel base over backfilled trenches as may be required by the agency having jurisdiction over the road in which he is working, in order to maintain the street in a passable condition prior to repaving. It shall be the responsibility of the Contractor to control dust on all roads, drives and walkways on which traffic is being maintained.
6. In roadways and rights-of-ways subject to jurisdiction of the MDOT SHA, all repaving and resurfacing shall be in strict conformance with MDOT

SHA Policies and Specifications, Standard Specifications and/or permit stipulations issued by same and/or details shown on Sheets SD-3.00, SS-1.00, PW-1.00, PW-1.10, PW-1.20, and PW-1.40 as applicable.

7. In roadways and right-of-ways subject to jurisdiction of the Town of Denton, paved or unpaved surfaces shall be restored to a condition at least equal to that existing before any excavation was commenced and as specified here in and/or detailed on Sheets SD-3.00, SS-1.00, PW-1.00, PW-1.10, PW-1.20, and PW-1.40 as applicable.
8. Contractor must maintain an adequate quantity of asphalt cold patch to meet the needs of temporary roadway material as a prerequisite to proceeding with the work.

#### B. Bituminous Surface Treatment

1. Where existing bituminous surface treated pavement is disturbed, bituminous surface treatment restoration shall consist of initial prime coat and triple bituminous surface treatment within the limits of pavement resurfacing as shown on the plans.
2. Prior to the application, all existing paved surfaces shall be properly prepared, including filling and grading of all holes and depressions and surface removal of all waves, bumps, and corrugations. The full roadway width shall then be swept for removal of dust, debris and loose or foreign materials and a prime coat applied to all newly prepared surfaces.
3. Bituminous surface treatment shall be in conformance with construction requirements of the MDOT SHA Standard Specification Section 904 – Performance Graded Asphalt Binders and Asphalt Mixes.

#### C. Bituminous Concrete Pavement

1. Where existing bituminous concrete pavement is disturbed, bituminous concrete pavement restoration shall be as detailed herein and as shown on Sheet SS-1.00. Base course shall be crusher run or air cooled crusher run blast furnace slag, furnished, and placed in conformance with MDOT SHA Standard Specification Section 901 - Aggregates and to existing thickness, lines, and grades. No base course shall be constructed until adjacent curb and gutter is in place.
2. Hot mix, hot laid bituminous concrete pavement for streets shall be furnished and placed to existing lines and grades or as shown on Detail Sheet PW-7.00 – Pavement Restoration and shall be in conformance with applicable provision of MDOT SHA Standard Specification Section 504 –

Asphalt Pavement. Protect curb and gutter during placement of bituminous concrete pavement. Any disfigurement of the curb and gutter during pavement operations shall be promptly remedied by the Contractor.

3. The pavement shall be placed in two layers as shown on Detail Sheet PW-7.00.
4. Each truck load of bituminous concrete shall be weighed and certified as to accuracy and temperature of each load. One copy of this certification shall be delivered to the Engineer or his representative at the time of delivery to the project.
5. Catch basins, inlets, curbs, and all other appurtenances shall be adequately covered and protected prior to application of prime coats and surface courses. No bituminous materials shall be allowed to enter any storm drainage system and suitable containment provisions shall be employed to prevent surface runoff of bituminous materials.

D. Topsoiling and Finish Grading

1. Topsoil all non-paved non-driveway disturbed areas per MDOT SHA Standard Specification Section 701 – Subsoil and Topsoil.
2. Topsoil shall be considered to mean a good friable original sandy or silty loam surface soil, typical of the area, which is capable of supporting native plant growth. Topsoil shall have a pH of 6.0 to 6.8 and ground limestone shall be added and thoroughly incorporated into the soil for pH adjustment as required. Topsoil shall be free of heavy clay, coarse sand, lumps, frozen clods, sticks, roots, or other foreign materials harmful to plant growth.
3. Prior to topsoiling and finish grading operations, all rough graded areas shall be corrected, mounds and ridges shall be cut off, gullies and depressions filled and other necessary repairs performed to enable all surfaces to be brought to the grades shown on the drawings and/or as specified herein, in an even and properly compacted condition.
4. Topsoil shall be placed at a depth of a minimum of 4 inches. Topsoil after subsequent operation shall be raked smooth and rolled lightly. After spreading of topsoil, all large stiff clods, hard lumps, large rocks, roots, stumps, litter, or other foreign matter shall be raked up and removed from the topsoil area and disposed of by the Contractor.

E. Seeding and Mulching

1. Seed and mulch all topsoiled areas and/or as noted on the plans.

2. Seeding and mulching shall be performed in accordance with MDOT SHA Standard Specification Section 704 – Temporary Mulch and Temporary Seeding.

3. Materials:

a. All seed shall be fresh, clean, from new crop seed. It shall be delivered to the site unopened in original packages which have, affixed to the packages, the guaranteed analysis by a recognized authority.

b. All pre-mixed seed to be used on the project shall have a certified stamped, signed and dated (not older than 6 months) tag located on each bag. No seed shall be used on any project unless it has been certified as described.

c. Seed mixture shall be as follows:

	Minimum Percent Purity	Minimum Percent of Germination
25% Red Fescue (creeping)	98	95
55% Kentucky 31 Tall Fescue	98	85
20% Perennial Rye Grass	98	90

d. Mulch shall consist of air dried straw.

4. Seeding:

a. The area to be seeded shall be thoroughly loosened to a depth of not less than 4 inches, and if just prior to seeding, the top 2 inches of soil is loose, friable, and free of large clods, rocks, or other extraneous matter 3 inches or more in diameter measured at the widest dimension; and if shaped to the prescribed grade, it shall be a satisfactory seedbed and require no further work.

b. Lime shall be applied at the rate of up to 160 pounds per 1000 square feet and shall be applied separately and prior to fertilizing and seeding. The lime shall be spread evenly and be worked into the upper 2 to 3 inches of soil after which the seedbed shall have the proper, smooth grade.

c. Commercial fertilizer of analysis 20-16-12 shall be applied at the rate of 0 to 4.6 pounds per 1000 square feet.

d. Apply the specified seed mix evenly at the rate of 4.6 pounds per 1000 square feet immediately after fertilizing, and rake the fertilizer and seed evenly into the upper 1/4 of the soil.

- e. Until the project is finally accepted, the Contractor shall be required to mow and to maintain vegetation between 4 and 10 inches in height. Also, the Contractor will be required to repair or replace any seeding or mulching that is defective or becomes damaged during the one (1) year warranty and/or maintenance bond period.
- f. All seeding shall be done between the dates of August 1 to October 31, or March 1 to April 30, unless otherwise approved, in writing, by the Engineer. No seeding will be done on frozen ground or when the temperature is 32 degrees F or lower.

5. Mulching:

- a. Mulch as specified shall be hauled and uniformly and evenly applied within not more than 48 hours after seeding has taken place. Mulch shall be applied at the rate of a minimum of 65 pounds and a maximum of 90 pounds per 1000 square feet, so as to provide a loose depth of between 1 and 2-1/2 inches. A mechanical blower may be used to apply the mulch material, provided the machine has been designed and approved for that purpose. At least 90 percent of the mulch shall be 6 inch pieces or longer. Care shall be taken that machines are not used that cut the mulch into small pieces.
- b. All seeded areas shall be mulched as described above unless otherwise specified.
- c. All areas that are mulched shall be secured by the following method or by any other method approved by the Engineer.
  - 1) Secure straw mulch immediately after the completion of mulching operations by applying wood cellulose fiber uniformly over the straw without displacing the mulch.
  - 2) The Contractor is warned that all precautions will be taken to guard against damaging or disfiguring structures or property on or adjacent to the project and that he will be held responsible for any such damage resulting from his work.

F. Temporary Seeding Notes

- 1. Contractor shall be responsible for temporary seeding of disturbed areas where necessary or directed by the Engineer.
- 2. Temporary seeding shall conform to procedure outlined in MDOT SHA Standard Specification Section 704.



G. Miscellaneous Driveway Restoration

1. All non-paved driveway areas shall be restored in kind with acceptable like materials.
2. Crushed stone, washed gravel, or other aggregate type driveways and parking areas shall be restored by placement of a minimum 2-inch depth of compacted aggregate placed upon a properly prepared subgrade.

**END OF SECTION**

**This Page Intentionally Left Blank**

## **SECTION 2**

### **SANITARY SEWERS AND APPURTENANCES**

#### **1. GENERAL**

- A. The Contractor shall furnish all material for and shall construct the pipe lines and all required appurtenances at the locations and to the lines, slopes and elevations shown on the drawings or designated by the Engineer.
- B. All sewer pipe shall be polyvinyl chloride (PVC) pipe or ductile iron (DI) pipe.
- C. The Contractor shall submit certifications to the Engineer that all pipe, fittings, and joints are as specified herein.

#### **2. POLYVINYL CHLORIDE PIPE AND FITTINGS**

- A. Polyvinyl chloride (PVC) pipe, used for sewer construction, shall equal or exceed the requirements of ASTM D 3034 for 4-inch through 15-inch pipe and ASTM F 679 for 18-inch through 27-inch pipe. The PVC sewer pipe shall have a minimum standard dimension ratio (SDR) of 35 and the minimum pipe stiffness, as tested in accordance with ASTM D 2412, shall be 46 when measured under 5 percent deflection at 73 degrees Fahrenheit. Pipe shall be manufactured with integral wall bell and spigot joints in standard lengths not exceeding 20.0 feet.
- B. All polyvinyl chloride (PVC) pipe and fittings shall utilize an elastomeric O-ring gasketed joint assembled in accordance with the manufacturer's recommendations. The gasket shall meet the requirements of ASTM F 477. Fittings shall be manufactured by the pipe manufacturer or approved by the pipe manufacturer for use and compatibility with his pipe.
- C. Polyvinyl chloride wye branches, tee wyes, pipe stoppers and other fittings shall be manufactured in accordance with the same specifications and shall have the same thickness, depth of socket, and annular space as the pipe. Wye branches and tee wyes shall be complete pipe sections. Saddle wyes will not be permitted for use.
- D. Polyvinyl chloride pipe shall be delivered and stockpiled in unit pallets. Stacking of pallets above 5 feet in height will not be allowed. If pipe is stockpiled for more than 30 days prior to installation in the trench, it must be suitably covered with reflective material to protect the pipe from ultra-violet rays emanating from sunlight. Do not use plastic sheets. Allow for air circulation under covering.

E. Bowed sections of pipe will be unacceptable and installation of pipe which has bowed, whether or not the bow has been corrected, will not be allowed on this project.

F. Pipe and fittings shall be marked with the date and location of manufacture. Pipe and fittings not marked shall be rejected.

### **3. DUCTILE IRON PIPE AND FITTINGS**

A. Ductile iron pipe, for sewer construction, shall be Grade 60-42-10, centrifugally cast in accordance with ANSI A21.6 or A21.8, with mechanical or push-on (Tyton) joint ends, not less than 12 feet nor more than 20 feet in length. Ductile iron sewer pipe shall be Class 50, unless otherwise noted or directed by the Engineer, in accordance with ANSI A21.51 (AWWA C151).

B. Fittings and specials for ductile iron pipe shall be made of cast iron in accordance with ANSI A21.10 and rated for 250 psi working pressure.

C. Each length of pipe and each fitting shall be marked with the weight and shall have distinctly cast upon them the pressure rating. Each length of pipe and each fitting shall have the manufacturer's identification and the year of manufacturer painted in a conspicuous location. Ductile iron pipe shall have the letters "DI" or "Ductile" cast or stamped on the pipe.

D. All pipe and fittings shall be double cement lined inside and be bituminous coated inside and out per ANSI A 21.4.

### **4. PIPE INSTALLATION**

A. Pipe and fittings shall be carefully handled and lowered into the trench. Special care shall be taken to insure that each length shall abut against the next in such manner that there shall be no shoulder or unevenness of any kind along the inside of the pipe.

B. Before pipe is placed, the bottom of the trench shall be carefully shaped to fit the lower part of the pipe exterior with reasonable closeness for a width of at least 60% of the pipe width as indicated on the plans. Bell holes shall be dug sufficiently large to insure the making of proper joints and so that after placement, only the barrel of the pipe receives bearing pressure from the trench bottom. No pipe shall be brought into position until the preceding length has been thoroughly bedded and secured in place. Any defects due to settlement shall be made good by the Contractor without additional compensation, therefore.

C. Proper and suitable tools and appliances for the safe and convenient handling and laying of pipe shall be used. Pipe shall be laid to the grades indicated on the Drawings. Pipe shall be laid with the bell ends uphill.

D. Whenever a pipe requires cutting to fit into the line or to bring it to the required location, the work shall be done in a satisfactory manner so as to leave a smooth end.

E. The pipes shall be thoroughly cleaned before they are laid and shall be kept clean until the acceptance of the completed work. The open ends of all pipe lines shall be provided with a stopper carefully fitted so as to keep dirt and other substances from entering. This stopper shall be kept in the end of the pipe line at all times when pipe laying is not in actual progress.

F. All concrete required to support and reinforce wye branches, tee wyes, bends, fittings, and concrete encasements shall be placed as directed, and the cost thereof shall be included and covered within the unit price bid. Supports are to be as detailed on the drawings. Concrete encasement will be a minimum of 6" thick around the pipe or as detailed on the drawing.

G. Backfill materials shall be hand placed and mechanically tamped in six inch layers, placed uniformly on both sides of the pipe, to a point at least one foot above the pipe crown. Each layer shall be thoroughly compacted for the full trench width and under, around and over the pipe. Mechanical tampers shall exert a pressure of not less than 250 foot pounds per square foot of area of tamping face.

H. For refill of the remaining trench depth, refer to Section 1 "Excavation, Backfill and Surface Restoration".

I. A minimum vertical separation of 18 inches between water mains and sewer lines shall be maintained throughout the project. Where this condition is not met, the sewer main shall be encased in concrete in accordance with the associated detail. Where water mains and sewer lines cross, sewer pipe joints shall be equidistant from the intersection and as far from water main joints as possible.

## **5. JACKED INSTALLATIONS**

A. At the locations, and to the limits indicated on the plans, and where stipulated in permits issued by governing agencies, pipe shall be installed using the "dry-cased" method of jacked construction. Open cut construction will not be permitted at these locations.

B. A complete detailed design procedure and method shall be submitted for each such installation and, as a minimum shall contain layout sketches indicating pit dimensions and location with respect to adjacent structures, complete details of the approach pit including design and details of the backstop, face and side bracings, material and equipment specifications and a sequence of operations. The backstop shall be so designed as to withstand a reaction in excess of the maximum jack capacity.

C. It is suggested that the Contractor retain the services of a jacking installation specialist in an effort to preclude the necessity for a restart at a second location due to inadequacies that could be foreseen through the use of such a specialist. Any such additional costs associated with such a restart at a new location shall be borne by the Contractor.

D. The direction of the jacking operation shall generally proceed upstream to allow for groundwater drainage to the approach pit. The approach pit shall be maintained in a dry condition through the use of crushed stone, or quarry waste, and an adequately sized sump pump. Such materials shall be included in the lump sum price bid for jacking.

E. The installation of the casing pipe shall proceed simultaneously with the boring excavation and material removal. The jacked casing shall lead the boring removal operation by a sufficient distance at all times to minimize differential settlement caused by the creation of voids between the jacking sleeve and the surrounding soil. All such voids shall be filled by pressure grouting.

F. If an obstruction is encountered that prohibits the forward action of the pipe, and it becomes evident that it will be impossible to advance the pipe, operations shall cease and the pipe will be abandoned in place and filled completely with grout. Any such additional cost associated with such a restart at a new location shall be borne by the Contractor.

G. Pipe shall be supported with manufactured stainless steel banded - neoprene casing spacers. Custom spacers may be required to maintain design pipe grades within casing. Shop drawings shall be provided. Salt treated pipe spacers or carrier blocks banded to pipe will only be allowed by written authorization from the Town of Denton or its authorized representative on a case by case basis. Casing and carrier pipes shall be bulkheaded with 12-inches of cement grout at each open end. A 1-inch galvanized steel pipe is to be installed at the invert in the downgrade bulkhead. Alternatively, a manufactured boot, custom fitted for casing and pipe sizes, may be used. Boot shall be securely fastened with Stainless Steel bands for a water tight connection.

H. The Carrier pipe for 8" and larger gravity sewers and all force mains will be Ductile Iron as described in Section 2, Paragraph 2, page 2-1.

I. Steel casing pipes shall have a minimum nominal diameter of double the nominal diameter of the carrier pipe. Thickness shall be that required to meet the existing traffic, overburden and installation loadings shall be a minimum of 0.34 inch and shall conform to ASTM A-53 Grade B. The casing shall be constructed to such line and grade as to ensure installation of the carrier pipe to design grade and elevation as shown on the plans.

J. The jacking operation, once commenced, shall be continuous until such time as the jacked crossing is completed.

## **6. PLUGGING AND BYPASSING**

A. Sewers line sections shall be plugged as necessary to restrict sewer flow during pipeline replacement operations and only under direct supervision of the Town of Denton Department of Public Works.

B. The sewer plug shall be installed upstream of the affected sewer line section. The plug shall be of a design which permits the release of all or any portion of the sewage flow upstream of the plug.

C. The period of time the plug is left in place is to be determined by the Contractor with approval by Town of Denton Department of Public Works. Any damage resulting from flooding of, or backup of sewage into, upstream units is the sole responsibility of the Contractor.

D. The bypassing of sewer flow shall be accomplished as required during plugging operations to protect the sewer lines from damage that might be inflicted by excessive sewer surcharging and to prohibit flooding or damage to public or private property being served by the sewers involved. The Contractor is responsible for all damages.

E. The Contractor shall supply the necessary pumps, conduits, and other equipment for bypass pumping. The bypass system shall be of sufficient capacity to handle existing flows plus additional flow that may occur during periods of inflow. The Contractor will be responsible for furnishing the necessary labor and supervision to set up and operate the pumping and bypassing system. If pumping is required on a 24-hour basis, all engines shall be equipped in a manner to keep the pump noise to a minimum.

F. Standby or reserve pump(s) shall be available at the bypassing site. Capacity of the standby or reserve pump(s) shall be equal to, or greater than, the peak flow of sewage to the sewer line.

G. Bypass discharge piping shall be laid at grade from the manhole upstream of the plug to the first manhole downstream of the plug. All safety precautions such as barricades, flashers, flagmen, etc. shall be provided by and be the responsibility of the Contractor.

H. Upon completion of the bypass operation and disassembly of the bypass equipment, the interior of the manholes from which, and to which, sewage was bypassed shall be flushed.

I. Any spillage from disassembly of equipment or otherwise shall be flushed to the sewer. No discharge of sewage will be permitted during bypassing to any areas than as specified herein.

J. No separate payment shall be made for plugging and bypass operations. The cost for such work shall be included in the appropriate unit price bid for the item of work performed.

## **7. LAYING PIPE IN FREEZING WEATHER**

A. No pipe shall be laid upon a foundation into which frost has penetrated, nor at any time when the Engineer shall deem that there is danger of the formation of ice or the penetration of frost at the bottom of the excavation unless all required precautions as to the minimum length of open trench and promptness of backfilling are observed.

## **8. ARTIFICIAL FOUNDATION**

A. Whenever directed, the Contractor shall lay pipe upon an artificial foundation which he shall construct. Such foundation may consist of gravel, sills, planks, or other timber construction, or of concrete; all to be of the form and dimensions and placed in the manner required by the Engineer. All artificial foundations shall be of a character equal to that as hereinbefore specified.

## **9. PIPELINE DETECTION SYSTEM**

A. Pipeline detectable tape shall be installed continuously along each sewer. The tape shall be installed directly above each pipeline and twelve (12) inches from the ground surface.

B. The tape shall be Lineguard Type II Detectable Tape as manufactured by Lineguard Inc. of Wheaton, Illinois, or equal. The tape shall be a minimum of two (2) inches wide, green in color, imprinted with the words, "CAUTION-SEWER LINE BELOW", and be capable of being detected with inductive methods.

## **10. TESTING**

A. General: The Contractor shall furnish all labor, tools, materials, water, and equipment, including mirrors, flashlights or other artificial lighting, weirs, pump, compressors, stopwatch, gauges, and meters for testing in accordance with these specifications.

B. Leak Testing: Contractor shall conduct leakage tests on all portions of the sewers built under the contract. The Contractor shall furnish all necessary labor and material to perform the tests as specified herein and as directed by the Engineer. The Contractor may use either of the following two leak testing methods.



1. Infiltration/Exfiltration
  - a. All sewers above the ground water line will be tested by the exfiltration method. This method will involve plugging the lower manhole and filling the pipe section between manholes with water to a level two (2) feet above the top of pipe in the upstream manhole and measuring the volume of leakage by the drop in manholes. Water for exfiltration tests shall be furnished by the Contractor.
  - b. All sewers below the ground water line will be tested by the infiltration method. This method will involve measuring the amount of infiltration into the pipe section at the lower end of the pipe section by means of a weir installed in the pipe or by other means, as approved by the Engineer.
  - c. The sewer shall be tested in sections of not more than 1000 feet lengths unless otherwise directed by the Engineer. The section shall be tested immediately upon completion thereof and shall meet the appropriate requirements specified herein.
2. All sheeting shall be removed, backfill placed to finished grade, and dewatering operations ceased at least 72 hours prior to infiltration tests.
3. The Contractor shall replace or repair all visible leaks or defects on all sections of sewers failing to meet the leakage tests.
4. The maximum allowable leakage, as determined by the infiltration or exfiltration method shall be 10 gallons per inch of pipe diameter, per mile, per day (24 hours).
5. Low Pressure Air - The Contractor shall furnish all equipment and personnel to conduct this test in accordance with the following procedure:
  - a. All branch fittings and ends of lateral stubs shall be securely plugged to withstand the internal test pressures. The section of line being tested shall also be securely plugged at each manhole. All stoppers shall be adequately braced when required.
  - b. Air shall be slowly supplied to the plugged pipe line until the internal air pressure reaches 4.0 pounds per square inch greater than the average back pressure of any ground water that may submerge the pipe. At least two minutes shall be allowed for temperature stabilization before proceeding further.
  - c. The rate of air loss shall then be determined by measuring the time

interval required for the internal pressure to decrease from 3.5 to 2.5 pounds per square inch.

- d. The line shall be considered acceptable if the time, T, in seconds, required for the 1.0 psi pressure drop is not less than the following:

$$T = 0.0850 DK/Q$$

Where:

K = 0.000419DL, but not less than 1.0

Q = rate of loss of 0.00015 cu ft/min/sq ft. of internal surface

D = pipe diameter, in.

L = Length of line being tested, ft.

- e. See Table 1 below for specification time required for a 1.0 psig pressure drop for size and length of pipe indicated for Q = 0.0015.

**Table 1: Specification Time Required for a 0.5 Pressure Drop For Size and Length of Pipe Indicate for Q = 0.0015**

1 Pipe Dia. (in.)	2 Min. Time (min:sec)	3 Length for Min. Time (ft)	4 Time for Longer Length (sec)	100 ft	150 ft	200 ft	250 ft	300 ft	350 ft	400 ft
4	1:53	597	0.190 L	1:53	1:53	1:53	1:53	1:53	1:53	1:53
6	2:50	398	0.427 L	2:50	2:50	2:50	2:50	2:50	2:50	2:51
8	3:47	298	0.760 L	3:47	3:47	3:47	3:47	3:48	4:26	5:04
10	4:43	239	1.187 L	4:43	4:43	4:43	4:57	5:56	6:55	7:54
12	5:40	199	1.709 L	5:40	5:40	5:42	7:08	8:83	9:58	11:24
15	7:05	159	2.671 L	7:05	7:05	8:54	11:08	13:21	15:35	17:48
18	8:30	133	3.846 L	8:30	9:37	12:49	16:01	19:14	22:26	25:38
21	9:55	114	5.235 L	9:55	13:05	17:27	21:49	26:11	30:32	34:54

C. Mirror Test of Sanitary Sewers: Upon completion of pipe laying and backfilling to a point at least two (2) feet above the crown of the pipe, the Engineer will conduct a mirror test to check for defects, or leakage, and for horizontal or vertical misalignment. Mirror testing shall consist of reflecting sunlight or artificial light via mirrors through the completed section of pipeline, which, in order to be accepted, shall be true and straight in horizontal and vertical alignment to allow for the full passage of the reflected light.

D. Deflection Testing: Sanitary sewers shall be tested in the presence of the Owner's and the Contractor's representatives to determine the amount of vertical deflection in the completed pipe line as follows:

1. Deflection testing as specified hereinafter shall be accomplished by the Contractor on all sanitary sewers installed.
2. Installation of sanitary sewers shall be complete prior to the start of deflection testing. All sheeting shall be removed except where written approval by the Engineer has been obtained. All backfill shall be placed, consolidated and dewatering operations ceased 14 days prior to the start of deflection testing.
3. One of the following methods of testing shall be utilized:
  - a. A mandrel made of steel or aluminum, with a diameter equivalent to 95 percent of the inside diameter of the pipe to be tested shall be pulled through the pipeline, from manhole to manhole, by hand. If the steel ball is unable to pass through the pipe without applying excessive force (as judged by the Engineer), it will be construed as evidence that the pipe has deflected more than 5 percent of the inside pipe diameter. A permanent record of all testing with locations where excessive pipeline deflections occur shall be kept by the Contractor and forwarded to the Engineer after completion of testing on each line. If a mandrel is utilized, it shall be approved by the Engineer prior to use. Mandrels shall have an odd number of gauging plates. The minimum number of plates shall be nine with a contact surface length equal to the inside pipe diameter plus two inches for pipelines 10 inches in diameter and smaller. On larger diameters, the contact surface length shall equal the inside pipe diameter.
  - b. A deflectometer or a similar instrument, either of which must be approved for use by the Engineer shall be pulled through the pipeline from manhole to manhole. The instrument shall measure the vertical deflection in the pipeline to the nearest tenth of one percent. A permanent record of all testing with locations where excessive pipeline deflections (greater than 5% of inside diameter of pipe) occur shall be kept by the Contractor and forwarded to the Engineer after completion of testing on each line.
4. The Contractor shall immediately replace all sections of pipe which deflect more than 5 percent as measured by one of the foregoing methods.
5. All material and labor required for testing and replacement of pipelines shall be furnished by the Contractor and the cost thereof included in the prices bid for furnishing and laying sewers.

## **11. DEFECTS TO BE MADE GOOD**

A. If, at any time before the expiration of the guarantee period under this contract, any broken pipe, or any other defects are found in any of the lines or in any of the appurtenances, the Contractor shall cause the same to be removed and replaced by proper material and workmanship, without extra compensation for the labor and material required, even though such injury or damage may not have been due to any act, default, or negligence on the part of the Contractor. All materials shall be carefully examined by the Contractor for defects prior to installation, and any found defective shall be rejected for use.

**END OF SECTION**

## **SECTION 3**

### **SEWER HOUSE LATERALS AND APPURTENANCES**

#### **1. GENERAL**

- A. The Contractor shall furnish and lay, or install, all sewer house service pipes, fittings, and appurtenances in accordance with these specifications and as indicated on Detail Sheets SS-4.00 and SS-4.10.
- B. Sewer house service pipes shall be polyvinyl chloride (PVC) pipe or ductile iron (DI) pipe.
- C. All parcels whether developed or undeveloped will receive one (1) House Lateral cleanout, unless otherwise directed by the Engineer. House lateral cleanout shall be as detailed on Sheets SS-5.10 and SS-5.20.
- D. The use of tee wyes as part of the cleanout is unacceptable.

#### **2. PVC PIPE AND FITTINGS**

- A. All 6" PVC pipe and fittings shall be SDR 35 with gasket joints and shall comply with PVC pipe requirements of Section 2 – Sanitary Sewers and Appurtenances. All 4" PVC pipe and fittings shall be schedule 40. Saddle fittings and tee wyes shall not be acceptable. Provide all necessary adapters.
- B. All PVC pipe joints shall comply with the requirements of Section 2. All pipe shall be jointed in accordance with manufacturer's recommendation and as approved by the Engineer.

#### **3. DUCTILE IRON PIPE AND FITTINGS**

- A. Ductile iron pipe, for sewer construction, shall be centrifugally cast with push-on joints, not less than 12 feet nor more than 20 feet in length. Ductile iron sewer pipe shall be in accordance with ANSI A21.51 and shall be pressure class 350.
- B. Fittings and specials for ductile iron pipe shall be made of cast iron in accordance with ANSI A21.10 and rated for 250 psi working pressure.
- C. The weight, class or nominal thickness, and casting period shall be shown on each pipe. The manufacturer's mark, country where cast, year in which the pipe was produced, and the letters "DI" or "DUCTILE" shall be cast or stamped on the pipe. All required markings shall be clear and legible, and all cast marks shall be on or near the bell.

D. All pipe and fittings shall be double cement lined inside and be bituminous coated inside and out per ANSI A 21.4.

#### **4. SELECTION AND ARRANGEMENT**

A. The Contractor shall verify all dimensions of fittings, pipe, etc. so that all of the pipe work performed will fit together properly and will conform to the arrangements as shown on the drawings or directed by the Engineer.

#### **5. LAYING PIPE AND FITTINGS**

A. Pipe and fittings shall be carefully handled and lowered into the trench. The ends of pipe shall abut against each other in such manner that there shall be no shoulder or unevenness on the inside of the main.

B. Special care shall be taken to insure that the pipes are well bedded on a solid foundation, and any defect due to settlement shall be made good by the Contractor. Bell holes shall be dug sufficiently large to insure the making of proper joints.

C. Proper and suitable tools and appliances for the safe and convenient handling and laying of pipe and fittings shall be used. Care shall be taken to prevent the pipe from being damaged, and any pipe damaged in any way shall be replaced to the satisfaction of the Engineer by the Contractor.

D. Pipe and fittings shall be thoroughly cleaned before they are laid and shall be kept clean until the acceptance of the completed work. At the close of each work day the end of the pipe line shall be tightly closed with an expansion type stopper so that no dirt or other foreign substance may enter the line, and this stopper shall be kept in place until pipe laying is again resumed.

E. Whenever a pipe or fitting requires cutting, to fit into the line or to bring it to the required location, the work shall be done in a satisfactory manner so as to leave a smooth end. Cuttings left in pipe shall be removed before jointing.

F. All house connections shall be laid on a two percent (2%) grade unless otherwise directed by the Engineer.

#### **6. JACKED HOUSE LATERAL INSTALLATIONS**

See Section 2, Paragraph 5 - Jacked Installations.

#### **7. PIPE DETECTION SYSTEM**

See Section 2, Paragraph 9 - Pipeline Detection System.

## **8. HOUSE LATERAL CLEANOUTS**

A. House lateral cleanouts shall be as detailed on Sheets SS-5.10 and SS-5.20.

## **9. TESTING**

A. The Engineer shall be notified in advance of all tests and all tests shall be conducted to his entire satisfaction.

B. House connections and lateral lines shall be tested by methods specified in Section 2 of these specifications except mirror and deflection testing of sewer house lateral pipe will not be required.

C. Leaks and defects shall be repaired or otherwise remedied by the Contractor at no expense to the Owner and to the complete satisfaction of the Engineer, at whatever time they become apparent prior to the expiration of the guarantee period under this contract.

**END OF SECTION**

**This Page Intentionally Left Blank**



## **SECTION 4**

### **SANITARY SEWER MANHOLES AND CLEANOUTS**

#### **1. GENERAL**

A. The Contractor shall construct manholes of precast reinforced concrete risers and base sections where indicated and as detailed on Sheets SS-2.00 thru SS-2.20. The Contractor will not be allowed to field cut, break, or core pipe openings through precast manhole walls without prior approval from Engineer.

B. Manholes shall be built at such points on the pipelines and of such form and dimensions as are shown on the drawings or as may be directed. Manholes shall be built as pipe laying progresses and the Engineer may stop work entirely on laying pipe if manhole construction is delayed to such an extent as to be hazardous to construction or the public.

C. Manholes with more than three connections, pipes 24" or more in diameter, or drop connections shall have an inside diameter of 5 feet. All other manholes are to have an inside diameter of 4 feet.

D. Doghouse type manholes shall be used to facilitate connection of proposed sewers to existing sewers, where directed, and shall be of such form and dimensions as are shown on the drawings.

E. Distance between manholes shall not exceed 400 LF without Engineers approval.

#### **2. PRECAST REINFORCED CONCRETE MANHOLE SECTIONS**

A. Precast reinforced concrete risers, eccentric cones (use of slab tops subject to Engineer's approval or where shown on Drawings) and bases shall be as detailed on Sheet SS-2.00 - SS-2.20 and in conformance with ASTM Designation C 478. Joints between riser sections shall be fitted with a D-Lok manhole joint gasket meeting the requirements of ASTM Designation C 443.

B. Precast reinforced concrete base and riser sections shall be as manufactured by Atlantic Precast Concrete Corporation, Gillespie Precast Inc., or equal. Base section shall be manufactured using a monolithic pour.

C. Interior and exterior joint spaces of all manhole risers shall be mortared.

D. Lifting holes in the walls of precast reinforced concrete risers will be allowed. The lifting hole is to be formed by a plastic insert cast integrally into the manhole wall, to

assure water tightness. The hole is to be grouted flush with face of manhole wall after installation of manhole riser sections. Not more than two holes shall be cast in the walls of each riser section for the purpose of handling. Said insert is to be "Key-Lok" as manufactured by A-Lok Products or equal.

E. The manhole manufacturer is to identify all inlets and the outlet of each manhole. An "I" and an "O" painted over the hole will be acceptable.

### **3. CONNECTIONS AND STUBS**

A. All pipe-to-manhole connections shall be made by means of an integrally cast flexible connector which shall be A-Lok flexible manhole gasket as manufactured by A-Lok Corp., Trenton, New Jersey, or equal. The pipe-to-manhole seal shall be accordance with ASTM C-923.

B. Stub connections shall be constructed where indicated on the plans of the same material used for sewer construction and shall extend 4 feet in length outside of manhole wall. The outer end of the stub connection shall be plugged with an approved stopper, secured in place as directed.

### **4. BRICK**

A. Brick work shall be limited to flow channel and bench construction and frame adjustment courses. No other brick shall be used in manhole construction.

B. All brick shall conform to the "Standard Specifications for Sewer Brick," ASTM Designation C 32, Grade SS, except that the maximum absorption for the average of five bricks shall not exceed 10 percent; and the individual brick maximum shall not exceed 14 percent.

### **5. MORTAR**

A. Cement shall be in accordance with the "Standard Specifications for Portland Cement," ASTM Designation C 150 for Type II.

B. Sand shall be composed of sharp, angular, silicious grains, coarse, or graded from fine to coarse with the coarsest grains predominating, and sensibly free from clay, loam, dirt, mica, organic matter, or other impurities. Sand containing more than 5 percent by weight of foreign material shall not be used. This limit may be changed for special classes of work if hereinafter specified. Sand exhibiting more than an acceptable amount of fine matter or impurities may be required to be washed after delivery on the work or shall be rejected altogether. Sand for mortar shall be screened to reject all particles of a greater diameter than 1/4-inch and shall not contain more than 5 percent by weight of a very fine material.

C. Unless hereinafter specified otherwise, all mortar shall be composed of cement and sand of the character above specified. The proportion by volume shall be one part of cement to two of sand. One volume of cement shall be 94 pounds net. One volume of sand shall be 0.9 cubic feet, the sand not being packed more closely than by throwing it into a box in the usual way. Mortar shall be fresh mixed in small batches for the work in hand. Tight boxes or platforms made for the purposes shall be used. The sand and cement shall be thoroughly mixed dry, in the proper proportions, until a uniform color has been produced, whereupon a moderate dose of water shall be added, so as to produce a stiff paste of the proper consistency.

D. Sand obtained from the excavation shall not be used.

## **6. LAYING BRICK**

A. All brickwork shall be laid by competent mechanics.

B. All brick shall be laid in a full bed of mortar with all vertical and horizontal joints filled solid with mortar.

C. Joints shall be not less than 3/8-inch or more than 1/2-inch wide.

D. No brickwork shall be laid when the temperature is below 40 degrees or when the indications are for lower temperatures within 24 hours. The Contractor shall take such measures as may be approved to prevent brickwork from being exposed to freezing temperatures for a period of not less than five days after laying.

## **7. FLOW CHANNELS**

A. All manhole flow channels and benches shall be constructed of pre-cast concrete with care taken to secure smooth and even surfaces. Channel sections shall be built up to true line and radius, and curved sections shall provide a uniform transition in the flow direction. Flow channels shall be in accordance with Detail Sheet SS-2.40.

B. Materials and construction of flow channels shall be in accordance with appropriate sections for materials so used, as hereinafter specified.

## **8. DROP CONNECTIONS**

A. Drop connections shall be of the inside drop manhole type and shall be constructed as detailed on Sheet SS-2.10.

B. Drop connections shall be required where a vertical invert difference of greater than or equal to two (2) feet exists between influent and effluent sanitary sewers. Where the difference in elevation between incoming sewer and the manhole invert is less than 24 inches, the invert should be filleted to prevent solids deposition.

C. Nominal diameter of the drop connection and fitting shall be equal to the influent pipe diameter.

D. Stainless steel straps shall be bolted to the manhole wall in such a manner as to allow for future removal and replacement of drop sections. Straps shall be located within six (6) inches below each joint and at a minimum of three (3) feet on center elsewhere.

E. All joints for drop sections shall be rubber gasketed or friction type to facilitate future removal. Solvent weld joints will not be permitted.

## **9. MANHOLE STEPS**

A. Manhole steps shall be made of 1/2 inch diameter steel reinforcing rod, ASTM Designation A 615, Grade 60, encased in polypropylene plastic. Manhole steps shall have a notched tread ridge with retainer lug on each side.

B. Manhole steps shall be cast in place during manufacture of precast reinforced concrete risers and eccentric top sections. Embedment length shall be suitable for minimum 5 inch thick, precast reinforced concrete riser walls.

C. Manhole steps shall be spaced 12 inches apart. The maximum spacing from top of manhole to the first step shall not exceed 16 inches.

D. Manhole steps shall be OSHA approved and Model PS1 as manufactured by M.A. Industries, Inc., Peachtree City, Georgia, ICM, Inc., Jacksonville, Arkansas, or equal.

## **10. WATERPROOFING**

A. The exterior surface of all manholes shall receive a minimum two coat application of a coal tar type protective coating. The total average dry film thickness shall measure 24 mils with no single measurement to be less than 20 mils. Surfaces shall be prepared in accordance with the manufacturer's instructions and coatings applied in the factory in a manner acceptable to the Engineer. The coating material shall be Seaboard LN-12 Asphalt Gilsonite Paint as manufactured by Seaboard Asphalt Products, Baltimore, Maryland, or equal.

## **11. MANHOLE FRAMES AND COVERS**

A. Frames and covers for manholes shall be set by the Contractor as the work progresses. The frame shall be well bedded in mortar. Frame and covers shall be securely fastened to the top cone with bolts securely anchored.

B. Material for frames and covers shall be in accordance with the standard specifications for gray iron castings ASTM Designation A 48 for Class No. 30.

C. Frames shall be East Jordan Iron Works (EJIW) 154514 and covers shall be EJIW 15423 or Neenah R-1565 frame and cover or approved equal. Covers shall be labeled "Sanitary Sewer". Reference Detail Sheet SS-2.50.

## **12. INFILTRATION PREVENTION**

A. Contractor shall furnish and install manhole frame internal sewer guards as shown on Detail Sheet SS-2.60. The guards shall be made of non-corrosive materials and shall be positioned completely inside the manhole frame to the top of manhole cone. Sewer guards shall be Flexi Rib Seals as manufactured by Parson Environmental Products, Wernersville, Pennsylvania, or equal.

B. Contractor shall furnish and install watertight manhole inserts at all sanitary sewer manholes. The inserts shall be made of non-corrosive materials and shall be constructed so that the manhole cover can be removed without damage to air and vacuum relief valves mounted on the inserts. Inserts shall be Parson Model V2P by Parson Environmental Products, Wernersville, Pennsylvania, or equal. Reference Detail Sheets SS-2.50 and SS-2.60.

## **13. CLEANOUT FRAMES & COVERS**

A. Cleanout frames and covers shall be cast iron, watertight with recessed lifting holes as manufactured by East Jordan Iron Works Model 1566 for 6" or 1564 for 8" or equal, and as shown on Detail Sheet SS-3.10. Cleanout lid shall be marked "S".

**END OF SECTION**

**This Page Intentionally Left Blank**

## **SECTION 5**

### **PRECAST CONCRETE GREASE TRAP**

#### **1. GENERAL**

A. The Contractor shall provide all materials, labor, equipment, and services necessary to construct and install precast concrete grease trap as shown on Sheet SS-8.00 and in accordance with these specifications.

B. Grease traps shall be constructed of precast reinforced concrete. Tanks shall be watertight, non-corrosive, durable and structurally sound. All inlet and outlet connections shall be sealed with standard rubber gaskets.

C. Each grease trap shall be equipped with two concrete extension rights and cast iron manhole frame and cover as shown on Sheets SS-8.00 and SS-3.00.

#### **2. PRECAST REINFORCED CONCRETE GREASE TRAP**

A. Precast reinforced concrete grease traps shall be as detailed on Sheet SS-8.00 and shall be sized in accordance with Caroline County Health Department requirements. Traps shall be in accordance with applicable sections of ACI 318 and shall be designed to carry AASHTO HS 20-44 loads.

B. Concrete for precast reinforced grease trap shall consist of the specified portland cement, aggregates, admixtures, and water to produce the following properties:

1. Compressive Strength: 5,000 psi minimum at 28 days.

C. Concrete shall be placed in a continuous operation to prevent the formation of seams or planes of weakness and shall be thoroughly consolidated by internal and external vibration without dislocation damage to reinforcement.

D. Concrete shall be cured by steam in other suitable methods to secure 5,000 psi minimum at 28 days as indicated by compression cylinder tests (ASTM C 39).

E. Materials for use in manufacturing precast reinforced concrete grease traps shall be as follows:

1. Portland Cement: ASTM C 150, Type II
2. Aggregates: ASTM C 33
3. Water: Clean, fresh, potable
4. Air-Entraining Admixture: ASTM C 260

5. Water-Reducing Admixture: ASTM C 494, Type A
6. Reinforcing: ASTM A 615, Grade 60, deformed

F. Contractor shall provide shop drawings showing complete information for the fabrication and installation of precast units as well as indicating dimensions and cross sections, location, size, and type of reinforcement.

G. Grease traps shall be as manufactured by Rotondo/Penn-Cast, Inc, Telford, PA 18969, or equal.

### **3. INSTALLATION**

A. The excavation shall be large enough to allow safe, unencumbered working conditions, but in no case shall be less than two (2) feet beyond the tank perimeter. Excavations shall be free of standing water until backfilling is complete.

B. The grease trap shall be placed on undisturbed soil with a six (6) inch gravel bedding which has been leveled.

C. All grease traps shall be placed at a depth as shown on the Drawings.

D. Excavated material may be used for backfill provided that it meets the requirements in Section 1 - EXCAVATION, BACKFILL AND SURFACE RESTORATION.

E. Backfill materials shall be placed in uniform layers not more than eight (8) inches thick and compacted to not less than 95% of its maximum dry density. Tamping shall be done in a manner which will not produce undue stress or strain on the tank. Backfilling machinery shall not be permitted within five (5) feet of the excavated area.

**END OF SECTION**



## SECTION 6

### FORCE MAINS AND APPURTENANCES

#### 1. GENERAL

A. The Contractor shall furnish, lay, and test, all force main pipe, fittings, and appurtenances in accordance with these specifications and as indicated on the plans.

B. Force main pipe shall be polyvinyl chloride, high-density polyethylene PE4710, or ductile iron pipe. Size and wall thickness specifications shall be in accordance with approved drawings.

#### 2. POLYVINYL CHLORIDE PLASTIC PIPE AND FITTINGS

A. Polyvinyl chloride plastic pipe used for force main construction shall meet or exceed the requirements of C909 (DR18 and colored green), or ASTM D2241, SDR-21 pressure Class 200. Pipe shall be manufactured in lengths not exceeding 20 feet.

B. Polyvinyl chloride pipe shall be manufactured with integral wall bell and spigot joints which shall utilize a flexible O-ring rubber gasketed joint meeting the requirements of ASTM F 477. Pipe ends shall be beveled to accept gasketed fitting.

C. Each pipe section including bell or coupling shall be tested in accordance with conditions specified in ASTM D 618 and D 2241. Any pipe that leaks or is unable to withstand the test pressure shall be rejected. The test shall be conducted at the factory and certification stating that the operation has been conducted as specified and the pipe meets all conditions of this specification shall be submitted to the Engineer.

D. Polyvinyl chloride pipe shall be delivered and stockpile in unit pallets. Store pipe on flat surface. No stacking of pallets or random lengths above 5 feet in height will be allowed. If pipe is stockpiled for more than 30 days prior to installation in the trench, it must be suitably covered with reflective materials to protect the pipe from ultra-violet rays emanating from sunlight. Do not use plastic sheets. Allow for air circulation under covering.

E. Bowed sections of pipe will be unacceptable and installation of pipe which has bowed, whether or not the bow has been corrected, will not be allowed on this project.

F. All fittings and specials to be used for polyvinyl chloride pipe shall be of ductile iron with mechanical joints per AWWA C-110 and C-153.

### 3. HDPE PIPE AND FITTINGS

A. HDPE pipe and fittings sizes 1" thru 4" IPS diameters shall be supplied in accordance with AWWA C-901-17, or the latest version thereof and to the requirements of ASTM D3035.

B. The high-density polyethylene pipe and fittings shall be PE 4710. The pipe shall conform to ASTM 3350 with a cell classification of 445474C. All HDPE pipe less than 4-inch diameter shall be as manufactured by JM Eagle or approved equal, where Iron Pipe Sizes (IPS) are required. All wall stops for concrete thrust collars shall be manufactured by JM Eagle or approved equal.

C. The pipe, fittings and specials shall be from the same manufacturer. All fittings and specials shall have the same pressure rating as the pipe.

D. All pipe and fittings joints shall be fully restrained from movement due to thermal expansion/contraction forces.

E. The Contractor shall be permitted to arc the pipe in lieu of utilizing fittings for bends. The minimum bending radius and other pipe installation requirements shall be as recommended by pipe manufacturer.

F. Joints for the pipe and fittings shall be by butt fusion joining techniques in accordance with the manufacture's recommendations. Where joining pipe is required within the trench, electrofusion techniques may be used in lieu of butt fusion. Electrofusion couplings and saddles may be used where necessary. All Electrofusion couplings shall be made using a computer controlled automatic electrofusion system. The electrofusion system shall consist of couplings containing an integral heating source which is computer controlled for time, temperature, and jointing pressure for a consistent joint. Couplings shall be rated for the same working pressure as the pipe and shall have a built-in identification feature to automatically set fusion times. The electrofusion system shall include a current monitoring feature. All joints shall be made in accordance with the manufacturer's instructions.

G. Transition fittings shall be Polypropylene Compression Fittings suitable for use on HDPE and PVC pipe. Fittings shall be long term rated for 230 psi complying with ISO 14236 and meet the dimensional and performance requirements of AWWA C800 Fittings shall comply with NSF 61 and shall be "listed" by NSF. Fitting "Bodies" shall be Polypropylene. Fitting "Compression Nuts" shall be Acetal. Joint seal activation shall be accomplished solely by the Compression Nut. Joint "Seals" shall not "interfere" with pipe insertion. No beveling or lubrication of pipe shall be required. Fitting components shall not require dismantling prior to assembly on to pipe. Fittings shall be "3G" or "UTC" with "Slide & Tighten capability as manufactured by Philmac Pty Ltd. and represented by The Harrington Corporation (Harco) of Lynchburg, VA (434) 845-7094.

#### **4. DUCTILE IRON PIPE AND FITTINGS**

A. Ductile iron pipe shall have gasketed, mechanical joint or push-on (Tyton) joints, conforming to ANSI Standard A 21.51. It shall be Class 50 unless otherwise noted or directed by the Engineer. All fittings shall be made of cast iron in accordance with ANSI A 21.10 and rated for 250 psi working pressure. Fittings shall be provided with mechanical joint ends in accordance with ANSI A 21.11 except where noted on the plans or delineated in these specifications. All pipe and fittings shall be double cement-lined inside and bituminous coated inside and outside per ANSI A 21.4.

#### **5. AIR RELIEF VALVES**

A. Air vacuum relief valves shall be constructed of cast iron or composite body and cover, stainless steel trim and float, and shall have 2" N.P.T. inlet. Valves shall be APCO Model No. 400-Short Body as manufactured by the Valve and Primer Corporation, Chicago, Illinois, or A.R.I. Model No. D-025 as manufactured by A.R.I. USA in care of Rockacy and Associates, Charlottesville, Virginia or equal, suitable for sewage force main applications with working pressures to 150 pounds per square inch and sized for the specific application by the engineer of record.

#### **6. AIR RELEASE MANHOLES**

A. Air Release Manholes shall be located at high points and as required for long flat sections on the Force Mains and at such forms and dimensions as are shown on the Detail Sheet SS-7.20 or as may be directed.

B. Precast reinforced concrete manhole sections shall conform with Section 4, Paragraphs 2.A thru 2.D.

C. Manhole Steps shall conform with Section 4, paragraph 9.

D. Manhole Frame and Cover shall conform with Section 4, paragraph 11.

E. Tapping sleeves shall be manufactured of ductile iron, cast iron, or stainless steel and shall have a 2" N.P.T threaded outlet. Tapping sleeve shall be PowerSeal Model 3495AS as manufactured by PowerSeal Pipeline Products Corp., Wichita Falls, Texas or equal.

F. Isolation valve shall be a 2" stainless steel ball valve with hand actuator. Valve shall be FNW Model No. 310A as manufactured by FNW Corp., Portland, Oregon or equal.

## **7. FORCE MAIN DISCHARGE MANHOLE**

A. Force main discharge manholes will be as detailed on Detail Sheet SS-7.10 and shall be constructed at locations designated on the plans.

## **8. BUTTRESSING BENDS**

A. Concrete for buttresses on sanitary sewer force main pipe shall be 3000 psi concrete using Type II Portland Cement and shall be placed as directed and/or shown on Detail Sheets W-6.00 thru W-6.10.

## **9. LAYING PIPE, VALVES AND FITTINGS**

A. Pipe installation shall be as specified under Section 2 or as detailed on the plans.

B. Pipes shall be thoroughly cleaned before they are laid and shall be kept clean until acceptance of the completed work.

## **10. PIPELINE DETECTION SYSTEM**

A. Pipeline detectable tape shall be installed continuously along each force main. The tape shall be installed directly above each pipeline and twelve (12) inches from the ground surface.

B. The tape shall be Lineguard Type II Detectable Tape as manufactured by Lineguard Inc., of Wheaton, Illinois, or equal. The tape shall be a minimum of two (2) inches wide, green in color, imprinted with the words "CAUTION-SEWER LINE BELOW" and be capable of being detected with inductive methods.

C. Pipeline tracer wire shall be #8 AWG (0.1285" diameter), hard drawn, high carbon 1055 grade, extra-high strength solid copper-clad steel conductor rated at 30 volts, insulated with a 45 mil, high density, high molecular weight polyethylene (HDPE) insulation (green in color) rated for direct burial use at 600 volts. Tracer wire shall be installed with sufficient length inside valve boxes and valve pits for connection at ground surface. Tracer wire shall be by Copperhead Industries, Monticello, Minnesota, or equal.

## **11. TESTING**

A. The Contractor shall furnish all labor, tools, materials, including water, and equipment, including pumps, compressors, stopwatch, gauges, and meters for testing in accordance with these specifications.

B. The Engineer shall be notified in advance of all tests, and all tests shall be conducted to his entire satisfaction.

C. The force main shall be filled with water, supplied by the Contractor, and the pressure raised to obtain a minimum test pressure measured at the highest point of the section of pipeline under test. Particular care shall be taken to eliminate all air from the pipeline. The force mains shall be subject to a leakage test at the specified test pressure, measured at the highest point of the section of pipeline under test. This test shall be a minimum of four (4) hours duration during which time the leakage shall not exceed 25 gallons per inch diameter per mile per 24 hours. The Contractor shall make any and all repairs at his expense that may be necessary until the leakage test requirements have been met.

D. The test pressure for the force mains shall be 100 psi.

E. Leaks and defects shall be repaired or otherwise remedied by the Contractor at no expense to the Owner and to the complete satisfaction of the Engineer, at whatever time they become apparent prior to the expiration of the guarantee period under this contract.

F. The Contractor shall coordinate with the Owner to tone all detection wire after final pressure testing has been completed. All inadequacies in the tracing wire shall be immediately repaired by the Contractor at his expense to the complete satisfaction of the Engineer.

## **12. DEFECTS TO BE MADE GOOD**

A. If, at any time before the expiration of the guarantee period under this contract, any broken pipes, or any other defects are found in any of the lines or in any of their appurtenances, the Contractor shall cause the same to be removed and replaced by proper material and workmanship, without extra compensation for the labor and material required, even though such injury or damage may not have been due to any act, default or negligence on the part of the Contractor. All materials shall be carefully examined by the Contractor for defects, before placing, and any found defective shall not be placed in the line.

**END OF SECTION**

**This Page Intentionally Left Blank**

## SECTION 7

### WATER MAINS AND APPURTENANCES

#### 1. GENERAL

A. The Contractor shall furnish and install all water mains, valves, hydrants, fittings, corporation stops, house service piping and appurtenances as specified herein and as defined on the drawings or as directed by the Engineer. Provide all necessary adapters for connection to existing mains. The contractor is given the option of using PVC or ductile iron pipe under this contract except as required by railroad or State Highway permits or as noted on the contract drawings.

#### 2. POLYVINYL CHLORIDE (PVC) PIPE AND FITTINGS

A. Polyvinyl chloride (PVC) plastic pipe used for water main construction shall meet or exceed the requirements of AWWA C900 (4"-12") and C905 (16"-24") latest editions. It shall have outside diameters equal to ductile iron pipe with a standard dimension ratio (SDR) of 18. The pipe shall be rated for a working pressure of at least 235 psi and shall have a minimum ultimate hydrostatic strength of 600 psi.

B. Polyvinyl chloride pipe and fittings shall be manufactured with integral wall bell and spigot joints which shall utilize a flexible O-ring rubber gasketed joint conforming to ASTM F 477. Pipe ends shall be beveled to accept gasketed fittings.

C. Pipe shall be Blue in color and shall be NSF-61 and UL 1285 approved. Pipe shall be manufactured in lengths not to exceed 20 feet.

D. Each pipe section including bell or coupling shall be subjected to a hydrostatic test of not less than 500 psi for at least 10 seconds. Pipe shall be tested in accordance with conditions specified in ASTM D 618. Any pipe that leaks or is unable to withstand the test pressure shall be rejected. The test shall be conducted at the factory and certification stating that the test has been conducted as specified and the pipe meets all conditions of this specification shall be submitted to the Engineer.

E. All fittings for PVC water pipe shall be mechanical joint ductile iron per ASTM A536. Fittings 2-inch thru 24-inch diameter shall have a pressure rating of 350 psi and all fittings larger than 24-inch diameter shall have a pressure rating of 250 psi. Mechanical joints shall meet requirements of AWWA C153 and ANSI A21.53. Provide all joint accessories, as required, to connect with plain end of push-on joint pipe or cut pipe. Fittings shall be asphaltic coated outside, and cement lined with double thickness and seal coated inside in accordance with AWWA C104.

F. Polyvinyl chloride pipe specified herein is manufactured to ductile iron pipe size. However, if adapters for connecting polyvinyl chloride pipe to cast iron fittings and valves are necessary, they shall be of the type recommended by the pipe manufacturer. Adapters must be manufactured of material specified herein or approved by the Engineer. Furnishing and installing adapters shall be included in the unit prices bid for the pipe.

G. Polyvinyl chloride pipe shall be delivered and stockpiled in unit pallets, and stored on a flat surface. No stacking of pallets above 5 feet in height will be allowed. If pipe is stockpiled for more than 30 days prior to installation in the trench, it must be suitably covered with reflective materials to protect the pipe from ultra-violet rays emanating from sunlight. Do not use plastic sheets. Allow for air circulation under covering.

H. Bowed sections of pipe will be unacceptable and installation of pipe which has bowed, whether or not the bow has been corrected, will not be allowed.

### **3. DUCTILE IRON PIPE AND FITTINGS**

A. Ductile iron pipe shall be manufactured in accordance with AWWA C151, latest edition, and shall be pressure Class 3 with Tyton Joints. The Contractor shall have the option of furnishing mechanical or push-on joints conforming to the latest edition of AWWA C111.

B. Pipe and fittings shall have a standard exterior asphaltic coating approximately 1 mil thick per AWWA C151.

C. Pipe and fittings shall have an internal cement lining, double thickness, in accordance with AWWA C104. Internal lining must be NSF/ANSI 61 certified for drinking water.

D. All fittings shall be ductile iron, mechanical joint, and shall conform to Section 6, paragraph E.

### **4. GATE VALVES**

A. Gate valves shall be iron body, resilient seated, non-rising stems, mechanical joint ends, square nut operated, and shall open by turning counterclockwise.

B. Gate valves shall be in conformance with AWWA C-515, latest edition, and be rated for 350 psi max working pressure with 10 mils Pro-Guard fusion Bonding.

C. Gate valves shall be as manufactured by Mueller Co. Model A-2361, or equal.



## 5. VALVE BOXES

- A. Valve boxes shall be cast iron, three piece Buffalo screw type with 5-1/4 inch shafts and No. 6 round bases. Valve boxes shall be adjustable between the limits of 2'-4" and 3'-4". If necessary, the water main shall be lowered to provide adequate depth of installation of the valve box.
- B. Lids shall be extra deep with two holes and the word "WATER" cast in the upper surface.
- C. Valve box assemblies shall be as manufactured by Mueller, Model H-10357 or approved equal.

## 6. FIRE HYDRANTS

- A. Fire hydrants shall be per Town of Denton standards and shall be a traffic model compression type with 5-1/4" main valve opening, on 4-1/2" pumper nozzle and two 2-1/2" hose nozzles. Hydrants shall have a 6" side inlet mechanical joint shoe connection to accommodate the class of pipe hereinbefore specified. Depth of bury shall be suitable for a minimum trench depth of 4'-0".
- B. Hydrants shall conform with AWWA Specification C-502, latest edition and as shown on Detail Sheet W-5.00. Hydrant seat shall be provided with bronze to bronze threaded connection.
- C. Threading of pumper and hose nozzles shall conform to National Standard. Hydrants shall open by turning counter-clockwise (open left) and shall comply with AWWA specifications for the hydrant type specified. A certificate of inspection and test shall be furnished including submission of a flow and friction loss curve.
- D. The operating nut shall be pentagon shape measuring 1-1/2" National Standard point to flat.
- E. Non-kinking hose nozzle chains are required.
- F. Hydrants shall receive prime and shop coats of paint at the factory. Submit coating specifications for approval. Color of coating for hydrants shall be Safety Yellow. The Contractor shall be responsible within the prices bid for field touch up or repainting of hydrants as required.
- G. The entire hydrant assembly, including the valve seat and all moving parts, shall be removable from the top without the need to excavate and/or remove the hydrant.
- H. The design shall be such that lubrication of the operating threads is possible without disassembly.

I. Drain mechanisms shall be bronze to bronze to preclude galvanic corrosion of dissimilar metals and shall operate automatically with the opening and closing of the main valve.

J. Fire hydrants shall be Model B-62-B as manufactured by American-Darling Valve and Manufacturing Company or approved equal.

K. Hydrant Steamer Adapter shall be Model HPHA50-45NH/CAP, Storz 5" x 4 ½" NH Female with (2) setscrews, Storz Cap and SS Cable as manufactured by Harrington, Inc., Erie, PA or approved equal.

L. Provide operating wrenches and repair kits as specified by the Owner. Storz cap requires a Storz spanner wrench for removal.

## **7. LAYING WATER MAIN AND FITTINGS**

A. PVC pipe shall be installed in accordance with AWWA C 605, latest revision. Pipe and fittings shall be carefully handled and lowered into the trench. The ends of pipe shall abut against each other in such manner that there shall be no shoulder or unevenness on the inside of the main.

B. Use lubricants specified and supplied by pipe manufacturer and approved for water service for proper pipe joint installation.

C. Special care shall be taken to ensure that the pipes are well bedded on a solid foundation, and any defects due to settlement shall be made good by the Contractor at his own expense. Bell holes shall be dug sufficiently large to insure the making of proper joints.

D. Proper and suitable tools and appliances for the safe and convenient handling and laying of pipes and fittings shall be used. Care shall be taken to prevent the pipe wall from being damaged, and any wall damage shall be repaired to the satisfaction of the Engineer by the Contractor.

E. Pipe and fittings shall be thoroughly cleaned before they are laid and shall be kept clean until the acceptance of the completed work. At the close of each workday, the end of the pipeline shall be tightly closed with an expansion type stopper or plug so that no dirt or other foreign substance may enter the line, and this stopper or plug shall be kept in place until pipe laying is again resumed.

F. Whenever a pipe or fitting requires cutting, to fit into the line or to bring it to the required location, the work shall be done in a satisfactory manner so as to leave a smooth end, and without extra compensation. Polyvinyl chloride pipe shall be beveled in accordance with manufacturer's recommendation before making pipe joint.

G. In jointing pipe and fittings, the Contractor shall exercise particular care to ensure that the outside of the spigot and inside of the bell are entirely free of oil, tar, and greasy substances to insure a tight fit.

H. All concrete required to construct buttresses behind plugs, tees, bends and other fittings and anchorages above or beneath vertical bends shall be placed as directed and/or as shown on Detail Sheets W-6.00 and W-6.10. Concrete shall be 3,000 psi, with Type II Portland cement. The cost of concrete buttressing shall be included in the appropriate unit prices bid for furnishing and laying water main.

I. When indicated or as noted on the Drawings, water pipe shall be encased with 3,000 psi concrete, with Type II Portland cement.

## **8. INSTALLING FITTINGS, HYDRANTS, GATE VALVES AND VALVE BOXES**

A. Fittings, hydrants, gate valves and valve boxes shall be placed along the water mains at the locations indicated on the drawings or where otherwise designated by the Owner or Engineer.

B. A valve box shall be carefully placed over the bonnet of the gate valve with the top at the finished grade of the ground elevation or at such other elevation as the Owner or Engineer shall direct. It shall be set plumb. In tamping the backfill around the box, special care shall be taken to keep the box plumb and to have it firmly supported so as to avoid settlement. Any box which is found out of plumb, or which is not firmly supported, shall be excavated and reset in a satisfactory manner, at the Contractor's expense. Box shall be firmly supported on two 4-inch solid concrete blocks so as to avoid settlement.

C. Hydrant assemblies shall include connecting pipes, fittings, valve and valve box and hydrants. Ductile iron pipe with cast iron fittings shall be used exclusively throughout the assembly. The use of other pipe materials will not be permitted in construction of any portion of the hydrant assemblies.

D. All exterior bolts and nuts to be 316 stainless steel, epoxy coated interior and exterior, UL listed, FM approved.

## **9. JACKED INSTALLATIONS**

A. At the locations, and to the limits indicated on the plans, and where stipulated in permits issued by governing agencies, pipe shall be installed using the "dry-cased" method of jacked construction. Open cut construction will not be permitted at these locations. Jacked installations shall conform to Section 2, paragraph 5.

## **10. STERILIZATION OF WATER MAINS**

- A. The Contractor shall disinfect all water mains in accordance with AWWA Standard C 651, latest edition.
- B. The Contractor shall submit a chlorination plan at the preconstruction meeting for the Engineers approval.
- C. All water for disinfection and filling of mains and appurtenances shall be provided by the Contractor at no additional cost to the owner.
- D. The Owner shall select, employ, and pay for an independent testing agency to perform residual and bacteriological analyses of all disinfected mains.
- E. Contractor shall notify the Engineer when chlorination is completed and ready to have bacteriological and residual samples taken.
- F. Samples shall indicate a chlorine residual that is in the range of 0.2 mg/l to 1.0 mg/l.
- G. Should residual and bacteriological analyses be unsatisfactory to the Engineer, the Contractor shall re-chlorinate the main and notify the Engineer to take new samples. Re-chlorination including cost of taking samples shall be at the Contractor's expense.
- H. Water mains shall not be placed in service until the analysis is complete and approved by the Engineer.

## **11. TESTING**

- A. The Contractor shall furnish all labor, tools, materials, including water, and equipment, pumps, compressors, stopwatch, gauges, and meters, subject to the approval of the Engineer and Inspection Agency, for testing and/or replacement/repair of pipe in accordance with these specifications.
- B. The Contractor shall perform all testing and/or replacement/repair of the pipe in the presence of the Owner, Engineer, or designated representative. The cost for the Contractor's testing procedures shall be included in the prices bid for furnishing and laying water mains.
- C. The Owner, Engineer or Inspection Agency shall be notified in advance of all tests, and all tests shall be conducted to their entire satisfaction. All tests shall be conducted in the presence of the Inspection Agency.

D. Pressure Test:

1. After backfilling has been completed, all newly laid pipe and any valved section thereof shall be subject to a hydrostatic pressure test of 2-times the operating pressure of existing system and shall retain this pressure for a period of two hours without leakage. The procedure for the pressure test shall be as follows:
  - a. Each valved section of pipe shall be slowly filled with water and the specified test pressure shall be applied by means of a pump connected to the pipe in a manner satisfactory to the Engineer and Inspection Agency.
  - b. Before applying the specified test pressure, all air shall be expelled from the pipe. If permanent air vents are not located at all high points, the Contractor shall install corporation stops at such points so the air can be expelled.

E. Leakage Test:

1. After satisfactory completion of the pressure test, the Contractor shall conduct a leakage test. The Contractor shall furnish the gauge and measuring device for the leakage test. The Contractor shall furnish the pump, pipe connections, and other necessary apparatus. Leakage shall be defined as the quantity of water that must be supplied into a newly laid pipe or any valved section, to maintain the specified leakage test pressure.
2. After the air in the pipeline has been expelled and the pipe has been filled with water, the allowable leakage shall be not more than 25 gallons of water per inch diameter per mile per 24 hours at a pressure of 2-times the operating pressure of existing system, measured at the highest line elevation. Leakage test shall be carried out for not less than four hours duration and the allowable leakage prorated accordingly.

F. Should either test shown the main to be defective, the Contractor shall remedy such defects and retest the main as specified above. This procedure shall be repeated until the test requirements are met. Contractor is to bear full responsibility and cost for testing, repair, replacement, and retesting, at no additional cost to the Owner.

## **12. LAYING PIPE IN FREEZING WEATHER**

A. No pipe shall be laid upon a foundation into which frost has penetrated, nor at any time when the Engineer shall deem that there is danger of the formation of ice or the penetration of frost at the bottom of the excavation, unless all required precautions as to the minimum length of open trench and promptness of refilling are observed.

### **13. ARTIFICIAL FOUNDATION**

A. Whenever directed, the Contractor shall lay pipe upon an artificial foundation which he shall construct. Such foundation may consist of gravel or concrete, all to be of the form and dimensions, and placed in the manner required by the Engineer. All necessary excavation for the construction of artificial foundations shall be made by the Contractor.

### **14. PIPELINE DETECTION SYSTEM**

A. Pipeline detection tape shall be installed continuously along all water mains. The tape shall be installed directly above the water mains and twelve inches from the ground surface.

B. The tape shall be Lineguard Type III Detectable Tape as manufactured by Lineguard, Inc., of Wheaton, Illinois, or equal. The tape shall be a minimum of two inches wide, blue in color, imprinted with the words, "CAUTION--WATER LINE BELOW", and be capable of being detected with inductive methods.

B. Pipeline tracer wire shall be #8 AWG (0.1285" diameter) hard drawn, high carbon 1055 grade, extra-high strength solid copper-clad steel conductor rated at 30 volts, insulated with a 45 mil, high density, high molecular weight polyethylene (HDPE) insulation (blue in color) rated for direct burial use at 600 volts. Tracer wire shall be installed with sufficient length inside valve boxes and meter pits for connection at ground surface. Tracer wire shall be by Copperhead Industries, Monticello, Minnesota, or equal.

### **15. DEFECTS TO BE MADE GOOD**

A. If, at any time before the final acceptance of the contract, any broken pipes, or any defects, are found in the water mains or in any of their appurtenances, the Contractor shall cause the same to be removed and replaced with proper material and workmanship, without extra compensation for the labor and material required, even though such injury or damage may not have been due to any act, default, or negligence on the part of the Contractor. All materials shall be carefully examined by the Contractor for defects, just before placing, and any found defective shall not be placed in the line.

**END OF SECTION**

## SECTION 8

### WATER HOUSE SERVICES AND APPURTENANCES

#### 1. GENERAL

A. The Contractor shall furnish and install all corporation stops, house service pipe, meter assembly, covers, valves and appurtenances as indicated on the drawings, and specified herein. All underground service lines, valves and fittings shall conform to AWWA C800.

B. The Contractor shall provide all tools, equipment and accessories required for tapping all existing and new water mains and installing water services.

C. Detectable tape approved by the Engineer, shall be placed directly over all water services during backfilling operation so magnetic detection of service lines may be utilized in future by the Owner. Detectable tape shall be as specified in Section 7, paragraph 14.B.

D. Detectable tracer wire approved by the Engineer, shall be placed directly below all water services during backfilling operation so detection of service lines may be utilized in future by the Owner if detectable tape fails. Tracer wire shall be as specified in Section 7, Paragraph 14.C.

#### 2. HOUSE SERVICES

A. Standard Water service lines shall be PE4710 polyethylene pipe (PEP), 1.5 inch, SDR-7 iron pipe size unless otherwise shown on the plans. Service lines shall conform to AWWA C901 and ASTM D-2737. For houses with sprinkler systems, refer to Part 3 – Commercial Service. Pipe shall be as manufactured by JM Eagle or approved equal.

B. Corporation stops shall be 1.5 inch, Mueller #E-25009 or equal. The Contractor shall furnish and install insert stiffeners wherever a compression connection is used on plastic service lines. Stainless steel inserts shall be Mueller #529116, 505142, or equal.

C. Cutting tools shall be of the hollow, shell bit type for removal of pipe plug. For tapping PVC mains use only Mueller Plastic Cutting Tool. On multiple taps, space corporation stops as recommended by pipe manufacturer. Furnish saddles with standard AWWA corporation stop inlet thread, double strapped for tapping 6-inch PVC and smaller. Saddles shall be Romac stainless steel Style 306 or equal.

D. Curb stops, when required, shall be A.Y. McDonald Model 7610-33 or equal. Valve boxes shall be Bingham and Taylor Model 92D curb box or equal.

E. Prefabricated meter box assemblies shall be installed in locations shown on the drawings. Prefabricated meter box assembly-riser to be Mueller 330RD2430FDBS000454N for 2-1" meters, includes 2-1" angle lockwing ball valves, with 2-1" angle dual check valves, 1" x 18" brass risers with 1.5" MNPT inlet and 2-1" outlets. Inlet to have Mueller #E-15451 and outlet to have Mueller 1" MNPT adapters to connect to SDR-7 PEP IPS service lines. Meter box lids shall be as specified in paragraph F. No meter installation shall be placed in a traffic area or driveway unless otherwise approved by Engineer or Owner.

F. Meter boxes shall be PVC 24" I.D. with minimum wall thickness of 0.2". Meter box frame and covers shall be Vestal cast iron frame Model ER-1824 with plastic solid lid Model RMRC-20 with Kamstrup Antenna Counter bore underlid. For meters set in traffic areas Contractor shall furnish and install extra heavy lids. Lids shall have the word "Water" cast into the cover and include lifter worm locks. Contractor shall verify fit and compatibility of assembly components prior to ordering. Contractor shall supply meter box lid wrenches as required by the Owner.

G. Single meter pit assemblies shall be as shown on Sheet W-2.00. Dual meter pit assemblies shall be shown on Sheet W-3.00. Unless otherwise directed by the Town or Engineer, Sheet W-3.00 shall be used for all new connections.

### **3. COMMERCIAL SERVICE**

A. Service lines of sizes 1.5 inch and 2 inch shall be PE4710 Polyethylene SDR-7 PEP IPS, AWWA C-901, unless otherwise directed by the Engineer or Owner. Pipe shall be as manufactured by JM Eagle or approved equal.

B. Corporation stops shall be A.Y. McDonald Model 74701B33 or equal.

C. For tapping ductile iron pipe or PVC pipe, use Romac Style 306 stainless steel service saddle with 1.5 or 2 inch iron pipe threads. Use Teflon tape for threaded service connections. Do not torque saddles or sleeves without water pressure in main.

D. Curb stops, when required, shall be A.Y. McDonald Model 7610-33 or equal. Valve boxes shall be Bingham and Taylor Model 142R curb box or equal.

E. Meter pits and setters shall be as detailed on Detail Sheets W-4.00 and W-4.10. Prefabricated meter box assemblies shall be A.Y. McDonald #780 series riser style setters with angle ball valve with angle dual check valve with low bypass. Bypass to have ball valve. Setter to have female iron pipe threads. Use A.Y. McDonald # 7475333 male adapters to connect to service pipe.

F. Meter boxes are to be PVC, sizes 30" x 30" for 1-1/2 inch water meters and 36" x 30" for 2 inch water meters. PVC meter boxes are Bingham and Taylor Model PMP30 for 1-1/2 inch meters and PMP36 for 2 inch meters. Use Vestal Expanda ring Part #



32-048 for 1-1/2 inch meter pits and Part # 32-049 for 2 inch meter pits. Use 20 inch monitor frame for both 1-1/2 inch and 2 inch meter pits Part # 32-056 with Trumbull PVC meter lid 20 inch Model 36-5610 with bracket and Kamstrup Antenna Counter bore under lid. Lids shall be marked "Water".

#### **4. WATER METERS**

A. All water meters shall be by the same manufacturer. All meters shall be lead free and comply with AWWA standards and certified to NSF 61/ANSI 61 standards.

B. Meters shall have a totalizing register with 10,000,000 gallon capacity. All meters shall register in U.S. Gallons.

C. Residential meters ends shall be external straight pipe thread. Commercial and industrial meter ends shall be two-bolt oval, AWWA 125 lb. class flanges. The Contractor shall check all connecting fitting for compatibility prior to ordering.

D. Residential meters up to and including 1 inch shall be Kamstrup Model 2100, Ultrasonic Radio Read AMR and commercial/industrial meters shall be Kamstrup Model 3101 Ultrasonic Radio Read AMR..

#### **5. BLOWOFF HYDRANT**

A. Blow-off hydrants shall be required at all dead-end lines which extend past the last customer service and do not have a fire hydrant past the last customer service.

B. Hydrant shall be 2-inch Model #78 as manufactured by Kupferle Foundry Company, or equal.

C. Pit for buried installation shall be 24-inch as detailed on Sheet W-7.00. Pit shall be Bingham and Taylor Model MMP24 or equal. Furnish a traffic frame and cover as referenced in Part 2.F with words "Blow Off" cast in lid.

D. Blow-offs and associated drainage lines shall not be connected to any type of sewer or submerged in any stream or installed in any manner that would permit back siphonage into the Town's water distribution system.

**END OF SECTION**

**This Page Intentionally Left Blank**

## SECTION 9

### STORM DRAINS AND APPURTENANCES

#### 1. GENERAL

A. The Contractor shall furnish all material for and shall construct the pipelines and all required appurtenances at the locations and to the lines, slopes and elevations shown on the drawings or designated by the Engineer.

B. Storm drains and storm drain leads shall be corrugated metal pipe except where shown on the contract drawings or directed by the Owner or Engineer to be reinforced concrete pipe. The type, size and class of pipe shall be in accordance with the requirements specified herein and as shown on the drawings.

C. The Contractor shall submit certifications to the Engineer that all pipe, fittings, and joints are as specified herein.

#### 2. CORRUGATED METAL PIPE

A. Corrugated metal drainage pipe shall be metal-steel culvert pipe, aluminized steel (Type 2) pipe, or corrugated aluminum pipe as shown on the Contract Drawings, dictated by field conditions, and/or directed by the Engineer. All metal-steel culvert pipe shall be minimum 14 gauge, bituminous coated, and shall meet applicable requirements of AASHTO Specification M-36 and M-190. Aluminized steel pipe shall be minimum 16-gauge, Type 2, helical corrugated or spiral rib pipe conforming to AASHTO M-36. Corrugated aluminum pipe shall be minimum 16-gauge, helical corrugated pipe conforming to AASHTO M-196 and M-197.

B. Field joints shall be made with band couplers of the same alloy used in the pipe. Band couplers shall be 16 gauge, 7 inches wide, two-piece coupler and fastened with aluminized or galvanized steel bolts. Band coupling shall also conform to AASHTO M-36.

#### 3. REINFORCED CONCRETE PIPE

A. Pipe shall be Reinforced Concrete Pipe, Class IV, meeting AASHTO Specification M-170 with tongue and groove joints. Finished End Sections shall be reinforced to conform with Class IV pipe and shall meet SHA Standards.

B. All reinforced concrete pipe furnished under this contract shall have joints composed of concrete fitted with rubber gaskets as specified in Section 18 of ASTI Designation C-361 or other elastomeric gasketing approved by the Engineer.

C. The rubber gasket shall be the sole element depended upon to make the joint watertight under all conditions, including movement due to expansion, contraction, and normal settlement. Joints shall be made up according to the manufacturer's recommendations.

#### **4. HDPE PIPE**

A. Storm drain shall be ADS N-12 WT dual wall pipe per ASTM F2648 for pipe and fittings or approved equal. Joints shall meet ASTM 3212 and ASTM C969.

B. In non-paved areas, minimum cover shall be 24 inches and in paved areas, minimum cover shall be 12 inches measured to the bottom of the bituminous concrete.

#### **5. PIPE INSTALLATION**

A. Pipe and fittings shall be carefully handled and lowered into the trench. Special care shall be taken to ensure that each length shall abut against the next in such manner that there shall be no shoulder or unevenness of any kind along the inside of the pipe.

B. Before pipe is placed, the bottom of the trench shall be carefully shaped to fit the lower part of the pipe exterior with reasonable closeness for a width of a least 60% of the pipe width as indicated on the plans. Bell holes shall be dug sufficiently large to insure the making of proper joints and so that after placement, only the barrel of the pipe receives bearing pressure from the trench bottom. No pipe shall be brought into position until the preceding length has been thoroughly bedded and secured in place. Any defects due to settlement shall be made good by the Contractor without additional compensation therefor.

C. Proper and suitable tools and appliances for the safe and convenient handling and laying of pipe shall be used.

D. Whenever a pipe requires cutting to fit into the line or to bring it to the required location, the work shall be done in a satisfactory manner so as to leave a smooth end.

E. The pipes shall be thoroughly cleaned before they are laid and shall be kept clean until the acceptance of the completed work. The open ends of all pipelines shall be provided with a stopper carefully fitted so as to keep dirt and other substances from entering. This stopper shall be kept in the end of the pipeline at all times when laying is not in actual progress.

F. All concrete required to support and reinforce wye branches, bends and other fittings shall be placed as directed.

G. Backfill materials shall be hand placed and mechanically tamped in six-inch

layers, placed uniformly on both sides of the pipe, to a point at least one foot above the pipe crown. Each layer shall be thoroughly compacted for the full trench width and under, around and over the pipe. Mechanical tampers shall exert a pressure of not less than 250-foot pounds per square foot of area of tamping face.

H. For refill of the remaining trench depth, refer to Section "Excavation and Backfill".

## **6. LAYING PIPE IN FREEZING WEATHER**

A. No pipe shall be laid upon a foundation into which frost has penetrated, nor at any time when the Engineer shall deem that there is danger of the formation of ice or the penetration of frost at the bottom of the excavation unless all required precautions as to the minimum length of open trench and promptness of backfilling are observed.

## **7. ARTIFICIAL FOUNDATION**

A. Whenever directed, the Contractor shall lay pipe upon an artificial foundation which he shall construct. Such foundation may consist of gravel or concrete; all to be of the form and dimensions and placed in the manner required by the Engineer. All artificial foundations shall be of a character equal to that as hereinbefore specified.

## **8. DEFECTS TO BE MADE GOOD**

A. If, at any time before the expiration of the guarantee period under this contract, any broken pipe, or any other defects are found in any of the lines or in any of the appurtenances the Contractor shall cause the same to be removed and replaced by proper material and workmanship, without extra compensation for the labor and material required, even though such injury or damage may not have been due to any act, default, or negligence on the part of the Contractor. All materials shall be carefully examined by the Contractor for defects prior to installation, and any found defective shall be rejected for use.

**END OF SECTION**

**This Page Intentionally Left Blank**

## SECTION 10

### STORM DRAIN MANHOLES AND CATCH BASINS

#### 1. GENERAL

A. The Contractor shall construct manholes and catch basins of reinforced concrete risers and base sections as detailed on Sheets SD-1.00 thru SD-2.10.

B. Manholes and catch basins shall be built at such points on the pipelines and of such form and dimensions as are shown on the Drawings or as may be directed by the Owner or Engineer. Manholes and catch basins shall be built as pipe laying progresses and the Owner or Engineer may stop work entirely on laying pipe if manhole construction is delayed to such an extent as to be hazardous to construction or the public.

C. Precast reinforced concrete risers, eccentric cones (use of slab tops subject to Engineer's approval) and bases shall be as detailed on Sheet SD-1.00 and SD-1.10 and in conformance with ASTM Designation C 478. Manhole joints between sections shall be fitted with D-LOK ring rubber gasket, meeting the requirements of ASTM Designation C 443. Installation shall be in accordance with manufacturer's recommendations.

D. Precast reinforced concrete base and riser sections shall be as manufactured by Atlantic Concrete Products Company, Gillespie Precast Inc, or equal.

E. Lifting holes in the walls of precast reinforced concrete risers will be allowed but shall be plugged with rubber stoppers and grouted flush with face of manhole wall after installation of manhole riser sections. Not more than two holes shall be cast in the walls of each riser section for the purpose of handling.

#### 2. CATCH BASINS AND JUNCTION BOXES

A. Catch basins and junction boxes to be constructed in accordance with applicable sections of MDOT SHA Section 350 – Miscellaneous Structures and as shown on Detail Sheets SD-2.00 and SD-2.10. Catch basins and junction boxes shall be of reinforced concrete construction.

B. Catch basins and junction boxes shall be built at such points on the pipe lines and of such form and dimensions as are shown on the drawings or as may be directed. All flow channels shall be formed of brick or concrete in the bottom of catch basins and shall slope smoothly and evenly from the pipes entering the catch basin to the outlet pipe.

C. All concrete catch basins and junction boxes shall be waterproofed with two (2) coats of Seaboard LN-12 Asphalt Gilsonite paint or approved equal.

D. Mortar cement shall be in accordance with the "Standard Specification for Portland Cement" ASTM Designation C150 for Type II.

E. Precast reinforced concrete catch basins and junction boxes shall be as manufactured by Atlantic Concrete Products Company, Gillespie Precast Inc. or approved equal.

F. Catch basin steps or metal ladder rungs shall be in accordance with MDOT SHA Standard Detail 383.91 and 383.92.

### **3. POURED-IN-PLACE CONCRETE:**

A. All concrete for manhole and catch basin slabs shall have a minimum compressive strength of 4,000 psi at 28 days.

### **4. MANHOLE STEPS**

A. Manhole steps shall be made of 1/2 inch diameter steel reinforcing rod, ASTM Designation A 615, Grade 60, encased in polypropylene plastic. Manhole steps shall have notched tread ridge with retainer lug on each side.

B. Manhole steps shall be cast in place during manufacture of precast reinforced concrete sections. Embedment length shall be suitable for minimum 5 inch thick, precast reinforced concrete riser walls.

C. Manhole steps shall be spaced 12 inches apart. The maximum spacing from top of manhole to the first step shall not exceed 16 inches.

D. Manhole steps shall be OSHA approved and Model PS1 as manufactured by M.A. Industries, Inc., Peachtree City, Georgia, or equal.

### **5. MANHOLE FRAMES AND COVERS**

A. Frames and covers for manholes shall be set by the Contractor as the work progresses. The frame shall be well bedded in mortar.

B. Material for frames and covers shall be in accordance with the standard specifications for gray iron castings ASTM Designation A 48 for Class No. 30 and as detailed on Sheet SS-3.10.



C. Frames shall be East Jordan Iron Works 154514 and covers shall be EJIW 154523 or Neenah R-1565 frame and cover or approved equal. "Storm Drain" shall be cast on the cover.

## **6. CATCH BASIN FRAMES AND GRATES:**

A. Frames and grates for catch basins shall be set by the Contractor as work progresses.

B. Material for frames and grates shall be in accordance with the standard specifications for gray iron castings ASTM A 48 for Class No. 30.

C. Frames and grates shall conform to the MDOT SHA Standard Details 374.12 and 374.13 for "NR" Inlet and 374.02 and 374.03 for "WR" inlet, as shown on Detail Sheets SD-2.00 and SD-2.10. Frames and grates shall be of the size and type detailed on the drawings.

## **7. FLOW CHANNELS**

A. All manhole flow channels and benches shall be Pre Cast Concrete with care taken to secure smooth and even surfaces. Channel sections shall be built up to true line and radius, and curved sections shall provide a uniform transition in the flow direction.

B. Materials and construction of flow channels shall be in accordance with appropriate sections for materials so used, as hereinafter specified.

## **8. BRICK**

A. Brick work shall be limited to flow channel and bench construction and frame adjustment courses. No other brick shall be used in manhole construction.

B. All brick shall conform to the "Standard Specifications for Sewer Brick", ASTM Designation C 32, Grade SS, except that the maximum absorption for the average of five bricks shall not exceed 10 percent; and the individual brick maximum shall not exceed 14 percent.

## **9. MORTAR:**

A. Cement shall be in accordance with the "Standard Specifications for Portland Cement," ASTM Designation C 150 for Type II.

B. Sand shall be composed of sharp, angular, silicious grains, coarse, or graded from fine to coarse with the coarsest grains predominating, and sensibly free from clay, loam, dirt, mica, organic matter, or other impurities. Sand containing more than 5

percent by weight of foreign material shall not be used. This limit may be changed for special classes or work if hereinafter specified. Sand exhibiting more than an acceptable amount of fine matter or impurities may be required to be washed after delivery on the work or shall be rejected altogether. Sand for mortar shall be screened to reject all particles of a greater diameter than 1/4-inch and shall not contain more than 5 percent by weight of a very fine material.

C. Unless hereinafter specified otherwise, all mortar shall be composed of cement and sand of the character above specified. The proportion by volume shall be one part of cement to two of sand. One volume of cement shall be 94 pounds net. One volume of sand shall be 0.9 cubic feet, the sand not being packed more closely than by throwing it into a box in the usual way. Mortar shall be fresh mixed in small batches for the work in hand. Tight boxes or platforms made for the purposes shall be used. The sand and cement shall be thoroughly mixed dry, in the proper proportions, until a uniform color has been produced, whereupon a moderate dose of water shall be added, so as to produce a stiff paste of the proper consistency.

D. Sand obtained from the excavation shall not be used.

#### **10. LAYING BRICK:**

A. All brick work shall be laid by competent mechanics, and any workmen not deemed to be such by the Engineer shall be removed from the work at once.

B. All brick shall be laid in a full bed of mortar with all vertical and horizontal joints filed solid with mortar.

C. Joints shall be not less than 3/8-inch or more than 1/2-inch wide except as otherwise specified in (e) below.

D. No brickwork shall be laid when the temperature is below 40 degrees or when the indications are for lower temperatures within 24 hours. The Contractor shall take such measures as may be approved to prevent brickwork from being exposed to freezing temperatures for a period of not less than five days after laying.

E. Special care shall be taken in laying brick in inverts of manholes to insure a uniform flow of water through the sections. In such locations, joints shall not exceed 1/16-inch in thickness and each brick shall be laid in full mortar bed with joints on bottom side and end made in one operation. No grouting or working in of mortar after laying the brick will be permitted.

#### **11. WATERPROOFING:**

A. All concrete structures shall receive two (2) coats of Seaboard LN-12 Asphalt Gilsonite paint or approved equal.

## **12. TESTS:**

A. If inspection reveals any visible leakage or seepage in any manhole, the Contractor will be required to accomplish such remedial measures as may be directed by the Engineer. Caulking or patching or interior manhole surfaces will not be acceptable.

## **13. CONNECTIONS TO EXISTING CATCH BASINS:**

A. Connections to existing catch basins shall be made where indicated on the drawings.

B. The size of opening through the wall of existing catch basin for connection of new pipe shall not exceed the outside diameter of pipe plus six (6) inches. All connections shall be fully grouted.

C. Flow channels in existing catch basins shall be reconstructed as necessary to provide smooth transition of flow from new connection.

**END OF SECTION**

**This Page Intentionally Left Blank**

## SECTION 11

### CONCRETE CURB, GUTTER, AND SIDEWALK

#### 1. GENERAL

- A. Contractor shall provide all material and appurtenances required to construct curb gutter and sidewalk to the lines and grades shown on the drawings or designated by the Engineer.
- B. Concrete curb, gutter and sidewalk shall be as detailed herein and as shown on applicable Town of Denton Detail Sheets PW-2.00 through PW-6.10.
- C. Contractor shall submit a mix design for concrete, including a complete list of materials including admixtures and the applicable reference specifications and copies of test reports showing that the mix has been successfully used to produce concrete with the properties specified.
- D. Contractor shall submit one copy of the delivery ticket for each load of ready-mixed concrete, showing all information required by ASTM C 94.
- E. Contractor shall also submit manufacturers' recommendations for the expansion joint material to be utilized. Clearly mark data to indicate which type, size or item is proposed. Data shall be sufficient to show conformance to specified requirements.
- F. Concrete shall not be delivered until forms, reinforcement and embedded items are in place and ready for concrete to be placed.
- G. Store reinforcement in a manner that will avoid excessive rusting or coating with grease, oil, dirt, and other objectionable materials.
- H. Sidewalk shall be 4-inches thick except at driveway entrances where thickness shall be 8-inches, or 6-inches with #10 wire mesh.
- I. Sidewalk ramps for the handicapped shall be as shown on applicable Town of Denton Detail Sheets PW-6.00 through PW-6.10.

#### 2. CONCRETE

- A. Contractor Furnished Mix Design: Design concrete mix in accordance with ACI 211.1. Slump shall be between 2 inches and 3 inches. The concrete shall have a 28-day compressive strength of 3000 pounds per square inch unless noted otherwise. The concrete shall contain no less than 6-1/2 bags of Portland Cement per cubic yard of concrete.

B. Air-Entrained Concrete: Provide for all concrete exposed to the weather. Compressive strength 3000 pounds at 28 days. Accomplish air-entrainment by using an air-entraining admixture, not air-entraining cement. If the entrained air content falls below the specified limit, add a sufficient quantity of admixture to bring the entrained air content within the specified limits. Dissolve the admixture in a portion of the mixing water and add to the mix in the drum in a manner that will ensure uniform distribution of the agent throughout the batch. The concrete shall have air entrainment of not less than 4 percent nor more than 6 percent and shall be so certified by the supplier.

### 3. MATERIALS

A. Cement: Type I Portland cement conforming to ASTM C 150, Type I.

B. Water: Water, including free moisture and water in the aggregates, shall be fresh, clean, and potable.

C. Aggregates: ASTM C 33, size no. 57 except as modified herein. Obtain all aggregates for exposed concrete surfaces from one source. Aggregates shall be free from any substance which may be deleteriously reactive with the alkalis in the cement. One-inch maximum aggregate size unless indicated otherwise.

D. Admixtures:

1. Air-entraining: Air entraining admixtures for concrete shall be in accordance with ASTM C 260, for all air-entrained concrete.
2. Accelerating: ASTM D 98, Type I or Type II. Use only when approved.

E. Materials for Forms: Forms shall be constructed of steel. Surfaces of forms shall be free from irregularities, dents, and sags. Other forms may be used in special circumstances with written authorization by the Engineer.

F. Welded Wire Fabric: ASTM A 185, 6" by 6" - #10 gauge (6" X 6" - W1.4 X W1.4) unless otherwise indicated.

G. Materials for Curing Concrete:

1. Impervious Sheeting: Waterproof paper, polyethylene sheeting, or polyethylene coated burlap conforming to ASTM C 171.
2. Liquid Membrane-Forming Compound: White pigmented compound, Type 2, free of paraffin or petroleum conforming to ASTM C 309.
3. Liquid Chemical Compound: A suitable sealer-hardener designed for sealing and hardening in addition to curing of the concrete, applied by the method and at the rate recommended by the manufacturer. It shall not

reduce the adhesion of paint or other material to be applied to the concrete. The chemical compound shall be free of petroleum resins or waxes.

H. Preformed Expansion Joint Filler: Preformed expansion joint filler, non-extruding and resilient bituminous types, in accordance with ASTM D 1751.

I. Vapor Retarder Material: Polyethylene sheeting, 6-mil nominal thickness.

#### **4. FORM WORK DESIGN REQUIREMENTS**

A. General: Provide forms for all concrete. Set forms true to line and grade and maintain so as to ensure completed work within the allowable tolerances specified, and make mortar-tight. Place forms so that they can be removed without damaging the concrete.

B. Coating: Before placing the concrete, coat the contact surfaces of forms with a non-staining mineral oil, non-staining form coating compound, or two coats of nitro-cellulose lacquer.

C. Tolerances and Variations: Set and maintain concrete forms to ensure that after removal of the forms no portion of the concrete work will exceed any of the tolerances specified in ACI 347.

D. All curb, gutter and sidewalk shall be in accordance with details as shown on applicable Town of Denton details.

#### **5. PLACING REINFORCEMENT AND MISCELLANEOUS MATERIALS:**

A. Provide all wire fabric as indicated or specified, together with all necessary wire ties, supports and other devices necessary to install and secure the reinforcement properly. All reinforcement, when placed, shall be free from rust, scale, oil, grease, clay and other coating and foreign substances that could reduce or destroy the bond. Rusting of reinforcement shall not be a basis of rejection, provided that the rusting has not reduced the effective cross sectional area of the reinforcement, and provided that loose rust shall be removed prior to placing.

B. Placing: Place reinforcement accurately and secure in place. On the ground, use concrete or other non-corrodible material for supporting reinforcement.

C. Splicing: Conform to ACI 318, except as otherwise indicated or specified. Where splices in addition to those indicated are necessary, they shall be approved prior to their use. Do not make splices at points of maximum stress. Make splices in welded wire fabric so that the overlap is not less than the spacing of the cross wires.

D. Setting Miscellaneous Material: Place and secure anchors and bolts, pipe sleeves, conduits, and other such items in position before the concrete is placed. Plumb anchor bolts, check for location and elevation and secure rigidly in position. Fill voids in sleeves temporarily with rapidly removable material to prevent the entry of concrete into the voids.

E. Expansion Joints: Make joints 1/2-inch wide except as indicated otherwise. Fill expansion joints flush with surface, with preformed joint material. Do not extend reinforcement or other embedded metal items bonded to the concrete through any expansion joint.

## **6. MEASURING, MIXING, TRANSPORTING AND PLACING CONCRETE**

In accordance with ACI 301, Chapters 7 & 8, except as modified herein.

A. Measuring: Make moisture, volumetric and air determinations at intervals specified herein under testing requirements. Allowable tolerances for measuring cement and water shall be 1 percent; for aggregates, 2 percent; and for admixtures, 3 percent.

B. Mixing: Machine mix all concrete. Begin mixing within 30 minutes after cement has been added to the aggregates. Introduce all mixing water in the drum before one-fourth of the mixing time has elapsed. The time elapsing between the introduction of the mixing water to the cement and aggregates or the cement to the aggregates and the start of placing of the concrete in final position in the forms shall not exceed 60 minutes if the air temperature is less than 85 degrees Fahrenheit, and 45 minutes if the air temperature is equal or greater than 85 degrees F. On arrival at the job site, no addition of water will be allowed other than that required initially to adjust to the specified slump. Such an addition must not exceed the limits of the specified maximum water-cement ratio.

C. Conveying: Convey concrete from the mixer to the forms as rapidly as practicable and so as not to cause segregation or loss of ingredients. Deposit concrete as close as practicable to its final position in the forms. At any point in the conveying, the free vertical drop of the concrete shall not exceed 3 feet. Clean conveying equipment thoroughly before each run. Do not use aluminum pipe or chutes. Place concrete as soon as practical after the forms and the reinforcement has been inspected and approved. Remove any concrete which has segregated in conveying and dispose of as directed.

D. Placing: Do not place concrete when weather conditions prevent proper placement and consolidation. Do not place concrete in uncovered areas during periods of precipitation. Do not place concrete in water. Prepare subgrades of earth or other material properly and, if necessary, cover with heavy building paper or other suitable material to prevent the concrete from becoming contaminated. Dampen porous subgrades as required to prevent water of hydration from being absorbed into the



subgrade. Clean forms of dirt, construction debris, water, snow, and ice. Place concrete in one continuous operation except where construction joints are provided. Place concrete in areas bounded by construction joints in one continuous operation. Remove water which accumulates on the surface of the concrete during placing by absorption with porous materials in a manner that prevents removal of cement.

E. Vibration: Consolidate concrete by wood tampers, spading and settling with a heavy leveling straight edge.

F. Cold Weather: Except with authorization, do not place concrete when the ambient temperature is below 40 degrees F or when the concrete is likely to be subjected to freezing temperatures within 24 hours. Remove lumps of frozen material and ice from the aggregates before placing aggregates in the mixer.

G. Hot Weather: Cool ingredients before mixing so as to prevent rapid drying of newly placed concrete. When the ambient temperature is more than 90 degrees F, the temperature of the concrete as placed shall not exceed 90 degrees F; shade the fresh concrete as soon as possible after placing; and start curing as soon as the surface of the fresh concrete is sufficiently hard to permit curing without damage to the concrete.

## **7. SURFACE FINISHES**

A. Finishing: The surfaces of the concrete shall be screeded by means of a template advanced with a combined longitudinal and crosswise motion, a slight surplus of concrete being maintained ahead of the template. After screeding, the concrete shall be floated longitudinally with a plank float, after which the surface shall be checked with a straight edge and corrected and refloated, as necessary. The sidewalk surface shall be scored and broom finished. Edges and joints shall be rounded with an edger having a radius of 1/4-inch.

## **8. CURING AND PROTECTION**

A. General Requirements: Protect concrete adequately from injurious action by sun, rain, frost, mechanical injury, and oil stains, and do not allow it to dry out from the time it is placed until the expiration of the minimum curing periods specified herein. Use impervious-sheeting curing, liquid chemical, or liquid membrane-forming compound, except as specified otherwise herein. Do not use membrane-forming compound on surfaces where its appearance would be objectionable, or where coverings are to be bonded to the concrete. Begin curing immediately following the removal of forms. Maintain the temperature of the air next to the concrete at no less than 40 degrees F for the full curing periods.

B. Impervious-Sheeting Curing: Wet the entire exposed surface thoroughly with a fine spray of water and then cover with impervious sheeting. Lay sheets directly on the concrete surface and overlap 12 inches. Make sheeting not less than 18 inches wider

than the concrete surface to be cured, and weight down on the edges and over the transverse laps to form closed joints. Repair or replace sheets if torn or otherwise damaged during curing. The sheeting shall remain on the concrete surface to be cured for not less than seven (7) days.

C. Liquid Membrane-Forming Compound Curing: Seal or cover all joint openings prior to application of the curing compound to prevent the curing compound from entering the joint. Compound shall remain on the concrete for seven (7) days before sealer or covering is removed and joint sealing material is placed in the joint.

D. Application: Apply the compound immediately after the surface loses its water sheen and has a dull appearance. Agitate curing compound thoroughly by mechanical means during use and apply uniformly in a two-coat continuous operation by suitable power-spraying equipment. The total coverage for the two coats shall be between 150 and 200 square feet per gallon of undiluted compound. The compound shall form a uniform, continuous, coherent film that will not check, crack, or peel and shall be free from pinholes or other imperfections. Apply an additional coat of the compound immediately to areas where the film is defective. Respray concrete surfaces that are subject to heavy rainfall within 3 hours after the curing compound has been applied in the same manner.

E. Protection of Treated Surfaces: Keep concrete surfaces to which liquid membrane-forming compounds have been applied free from foot and vehicular traffic and other sources of abrasion for not less than 72 hours. Maintain continuity of the coating for the entire curing period and repair damage to the coating during this period immediately.

F. Liquid Chemical Compound Curing: Provide for surfaces for which a sealer-hardener finish is specified, and, at the Contractor's option, provide in lieu of liquid membrane-forming compound curing for other surfaces. The application of the compound shall conform to the requirements for liquid membrane-forming compound curing except as specified otherwise herein. The coverage and number of applications shall be in accordance with the recommendations of the manufacturer of the compound.

G. Curing Periods: Cure not less than ten (10) days for concrete exposed to the weather and not less than seven (7) days for all other concrete.

H. Removal of Forms: Remove forms in a manner which will prevent damage to the concrete. Do not remove forms without approval, nor sooner than 24 hours after placement of concrete.

## **END OF SECTION**

## **SECTION 12**

### **PREPARATION OF ROADWAY BASE**

#### **1. GENERAL**

A. The Contractor shall perform all excavation, embankment, grading and compaction necessary to prepare for and construct streets, curb and gutter, sidewalk, driveways, seeded areas and miscellaneous work items associated therewith.

#### **2. EXCAVATION**

A. Excavate where necessary and stockpile material at a nearby site.

B. All organic matter, roots, etc. removed from within limits of construction shall be removed and disposed of. Stockpile topsoil for reuse in final grading, as applicable.

C. Material from excavation conforming to specifications for road base, embankment, or which can be processed to so conform, shall be re-used for base, embankment or refill below subgrade. The Contractor shall secure, and pay for, tests to verify suitability of material for reuse.

D. Material unsuitable for reuse, or not needed, shall be disposed of by the Contractor at an approved off-site location or as directed by the Owner.

E. The Contractor shall separate suitable from unsuitable material prior to stockpiling or removal.

F. The Engineers opinion regarding suitability of excavated material for use in preparation of subgrade shall be final . In general, organic material, refuse, large lumps or stones having any dimensions greater than 2 inch, paving material, frozen earth or materials which will not readily consolidated or compact in the trench will be considered unsuitable.

#### **3. EXCAVATION AND REFILL BELOW SUBGRADE**

A. Whenever the character of the material at the bottom of an excavation is such, in the opinion of the Engineer, as to require excavation to an additional depth of adequate foundation, such additional depth shall be excavated by the Contractor to the extent directed by the Engineer.

B. As directed, the Contractor shall use suitable material from excavation, special backfill, gravel or a combination thereof in refilling excavations below subgrade.

C. Gravel bedding shall be in accordance with MDOT SHA Section 901.01 for No. 57 gravel bedding.

D. Special backfill shall be in accordance with MDOT SHA Section 916.01.

#### **4. EMBANKMENT**

A. Construct where necessary, from suitable excavated or borrow material. Embankment to reach top of subgrade elevations necessary for construction of new work.

B. All material to be placed in embankment shall meet the requirements of MDOT SHA Section 916.

#### **5. ROAD BASE - AGGREGATE BASE COURSE**

A. Aggregate base course shall be constructed where shown and as detailed on the drawings. Base course shall be in conformance with MDOT SHA Section 901.01 for graded aggregate base. Base course shall be to the thickness, lines and grade shown on the Contract Drawings, and shall meet the minimum requirements shown on Detail Sheets PW-1.00 through PW-1.40.

B. Existing pavement removed under this contract may be recycled and reused for aggregate base course if properly processed to conform with gradation requirements of MDOT SHA Section 901.01 for graded aggregate base. The Contractor shall secure, and pay for, tests to verify suitability of material for reuse.

#### **6. COMPACTION**

A. Base shall be thoroughly compacted to a minimum of 95 percent of maximum dry density as determined by AASHTO T-180, Method A. In place density tests shall be conducted in accordance with AASHTO T-191 Method A to verify degree of compaction. Number and locations of Proctor and density tests shall be as determined by the Engineer.

B. Owner will select, employ and pay for services of an Independent testing agency to perform specified inspection, sampling and testing. All testing shall be coordinated and arranged by the Owner or Engineer. The testing agency shall submit a copy of all testing reports directly to the Engineer. Each report shall contain the project identification name and number, name of Contractor, name of testing agency, and location of sample tested, as a minimum.

C. For those tests which indicate compaction densities less than specified, the Contractor shall secure, at his own expense, the specified compaction using methods approved by the Engineer. Contractor shall reimburse the Owner for all costs associated with re-tests due to inadequate compaction.

**END OF SECTION**

**This Page Intentionally Left Blank**

**SECTION 13**  
**BITUMINOUS CONCRETE PAVEMENT**  
**AND**  
**BITUMINOUS SURFACE TREATMENT**

**1. GENERAL**

A. The Contractor shall place and construct bituminous concrete pavement consisting of base course and/or surface course as shown on Detail Sheets SS-1.00 and PW-1.00 thru PW-1.40 and as specified herein. All bituminous concrete base course shall be placed on the properly prepared, compacted and graded base or existing pavement as indicated on the Contract Drawings, and as specified in Section 12.

B. In areas where new curb and gutter are to be constructed, they shall be constructed prior to the placing of bituminous concrete.

C. Special care shall be taken to cover and protect curbs and gutters which are to remain exposed from the application of bituminous materials. The Contractor shall be responsible for the restoration to a like-new appearance of any new curb and gutter discolored by the Contractor's operations.

D. Manholes, catch basins, inlets, frames and covers, valve boxes and all other surface utilities shall be adequately covered and protected prior to the application of bituminous materials. Such materials shall not be allowed to enter any storm drainage or sewerage system and suitable containment provisions shall be employed to prevent surface runoff of bituminous materials.

**2. GRADED AGGREGATE BASE COURSE**

A. Aggregate base course shall be in conformance with the requirements of Section 12, Paragraph 5.

**3. TACK COAT**

A. Existing bituminous concrete and concrete surfaces designated for resurfacing shall be tack coated prior to the application of bituminous material.

B. Tack coat shall be residual asphalt uniformly spread at a rate of 0.01 to 0.05 gallons per square yard of surface area.

C. Tack coat shall be applied on a clean and dry surface.

#### **4. BITUMINOUS CONCRETE PAVEMENT**

A. Hot mix, hot laid bituminous concrete pavement for streets shall be furnished and placed to the lines and grades shown on the drawings and shall be in conformance with the materials and construction requirements of the MDOT SHA Section 504. Bituminous concrete shall not be placed when the temperature of the surface upon which the bituminous concrete is to be placed is below 60 F (16 C) for plant mixed seal; 40 F (4C) for courses having nominal depths of less than 1/1/2 inch. (40 mm); or 32 F (0 C) for any other course. The temperature of the mixture shall not be less than 225 F (107 C) at the time of placement. Protect curb and gutter during placement of bituminous concrete pavement.

B. The pavement shall be placed in two layers, and shall meet or exceed the minimum thickness requirement shown on Detail Sheets SS-1.00 and PW-1.00 thru PW-1.40.

C. Contractor shall submit one copy of the loading ticket for each load of bituminous concrete delivered. This ticket shall certify that the asphaltic concrete plant has not produced any other mix during the period of time during which mix for this project is being produced.

#### **5. BITUMINOUS SURFACE TREATMENT**

A. Where existing bituminous surface treated pavement is disturbed, bituminous surface treatment restoration shall consist of an initial prime coat and triple bituminous surface treatment within the limits of pavement resurfacing as shown on the plans.

B. Prior to the application, all existing paved surfaces shall be properly prepared, including filling and grading of all holes and depressions and surface removal of all waves, bumps and corrugations. The full roadway width shall then be swept for removal of dust, debris and loose or foreign materials and a prime coat applied to all newly prepared surfaces.

C. Bituminous surface treatment shall be in conformance with materials and construction requirements of the MDOT SHA Section 904.

**END OF SECTION**



## SECTION 14

### MISCELLANEOUS

#### 1. GENERAL

A. Refer to the Town of Denton website for additional ordinances on land use ([www.dentonmaryland.com](http://www.dentonmaryland.com)).

#### 2. STREET SIGNS

A. At every intersection, a street sign or street signs shall be placed having thereon the names of the intersecting streets. At intersections where streets cross, there shall be at least two (2) such street signs and at the intersections where one (1) street ends or joins with another street, there shall be at least one (1) such street sign. Street signs shall be as detailed on Sheet PW-8.00.

#### 3. DECORATIVE LIGHTING

A. Decorative lighting shall be as detailed on Sheet G-2.00. The following is a set of lighting standards and specifications generated for the Town of Denton and are in accordance with the 10th edition of the Illuminating Engineering Society of North America Lighting Handbook.

##### 1. Roadway Classifications:

- a. Expressway: A divided major roadway for through traffic with partial control of access and generally with interchanges at major crossroads.
- b. Major: The part of the roadway system that serves as the principal network for through traffic flow. The routes connect areas of principal traffic generation and important rural highways entering the city.
- c. Collector: The roadways serving traffic between major and local roadways. These are roadways used mainly for traffic movements within residential, commercial, and industrial areas.
- d. Local: Roadways used primarily for direct access to residential, commercial, and industrial, or other abutting property. They do not include roadways carrying through traffic. Long local roadways are generally divided into short sections by a system of collector roadway systems.

2. Area Classifications:

- a. Commercial: A business area of a municipality where ordinarily there are many pedestrians during night hours. This definition applies to densely developed business areas outside, as well as within, the central part of a municipality. The area contains land use that frequently attracts a heavy volume of nighttime vehicular and pedestrian traffic.
- b. Intermediate: Those areas of a municipality characterized by frequent moderately heavy nighttime pedestrian activity, as in blocks having libraries, community recreation centers, large apartment buildings, industrial buildings, or neighborhood retail stores.
- c. Residential: A residential development, or a mixture of residential and small commercial establishments, characterized by few pedestrians at night. This definition includes area with single family homes, town houses, and small apartment buildings.

3. Road Surface Classifications:

- a. Class R1: Portland Cement, concrete road surface. Asphalt road surface with a minimum of 15 percent of the aggregates composed of artificial brightener and aggregates.
- b. Class R2: Asphalt road surface with an aggregate composed of a minimum 60 percent gravel (size greater than 10 mm). Asphalt road surface with 10 to 15 percent artificial brightener in aggregate mix. (Not normally used in North America).
- c. Class R3: Asphalt road surface (regular and carpet seal) with dark aggregates (e.g., trap rock, blast furnace slag); rough texture after some months of use (typical highways).
- d. Class R4: Asphalt road surface with very smooth texture.

4. Roadway Illuminance Selections:

- a. Select the Average Maintained Illuminance Value from the table below for the Road, Area and Surface Classification identified above.

<b>Roadway Average Maintained Illuminance Values (Eavg.) in footcandles (fc)</b>					
<b>Road Classification</b>	<b>Area Classification</b>	<b>Pavement Classification</b>			<b>Illuminance Uniformity Ratio Eavg. to Emin.</b>
		<b>R1</b>	<b>R2 and R3</b>	<b>R4</b>	
Expressway	Commercial	1.0	1.4	1.3	3 to 1
	Intermediate	0.8	1.2	1.0	
	Residential	0.6	0.9	0.8	
Major	Commercial	1.2	1.7	1.5	3 to 1
	Intermediate	0.9	1.3	1.1	
	Residential	0.6	0.9	0.8	
Collector	Commercial	0.8	1.2	1.0	4 to 1
	Intermediate	0.6	0.9	0.8	
	Residential	0.4	0.6	0.5	
Local	Commercial	0.6	0.9	0.8	6 to 1
	Intermediate	0.5	0.7	0.6	
	Residential	0.3	0.4	0.4	

Note: When preparing Average Maintained Illuminance Calculations, use a Light Loss Factor (LLF) of 0.72(min.).

5. Walkway Illuminance Selection:

- a. Select the Maintained Illuminance Value from the table below for the specific type of Way Classification.

<b>Pedestrian Way Average Maintained Illuminance Values (Eavg) in footcandles (fc)</b>			
<b>Way Classification*</b>		<b>Minimum Average Horizontal Levels</b>	<b>Average Vertical Levels for Special Pedestrian Security (6' above walkway)</b>
Sidewalks (roadside)	Commercial	1.0	2.2
	Intermediate	0.6	1.1
	Residential	0.2	0.5
Walkways distant from roadways		0.5	0.5

\* Crosswalk traversing roadways in the middle of long blocks and at street intersections should be provided with additional illumination.

Note: When preparing Average Maintained Illuminance Calculations, use a Light Loss Factor (LLF) of 0.72(min.).

6. Parking Lot Illuminance Selection

- a. Select the Maintained Illuminance Value from the table below for the specific type of Parking Lot Classification.

<b>Maintained Illuminance for Parking Lots in footcandles (fc)</b>		
	<b>Basic</b>	<b>Enhanced Security</b>
Minimum Horizontal Illuminance	0.2	0.5
Uniformity Ratio (Maximum to Minimum)	20:1	15:1
Minimum Vertical Illuminance	0.1	0.25

Note: When preparing Average Maintained Illuminance Calculations, use a Light Loss Factor (LLF) of 0.72(min.).

7. Lighting Design Submission Requirements
  - a. Provide computer assisted lighting calculations for approval of each area of interest.
  - b. Provide a summary chart along with the calculations.

Example:

<b>Summary of Lighting Calculations</b>				
Description of Area	<b>Average Maintained Footcandles</b>	<b>Min.(fc)</b>	<b>Max.(fc)</b>	<b>Illuminance Uniformity Ratio Eavg. to Emin.</b>
Main Street	1.2	0.2	6.0	6.0

- c. Provide detailed shop drawings of the fixture with all options clearly identified for the town's review and approval.
- d. Calculation Workplane shall be taken at grade level.
- e. Calculation Grid shall be 10' x 10' for the entire area of interest.
- f. Use cutoff luminaires and avoid ones that emit light above the horizontal plane. In residential areas, minimize direct light onto nearby windows and illumination onto adjacent properties. Use internal house-side-shields, etc. wherever necessary.
- g. Coordinate with the town for provision of spare parts.

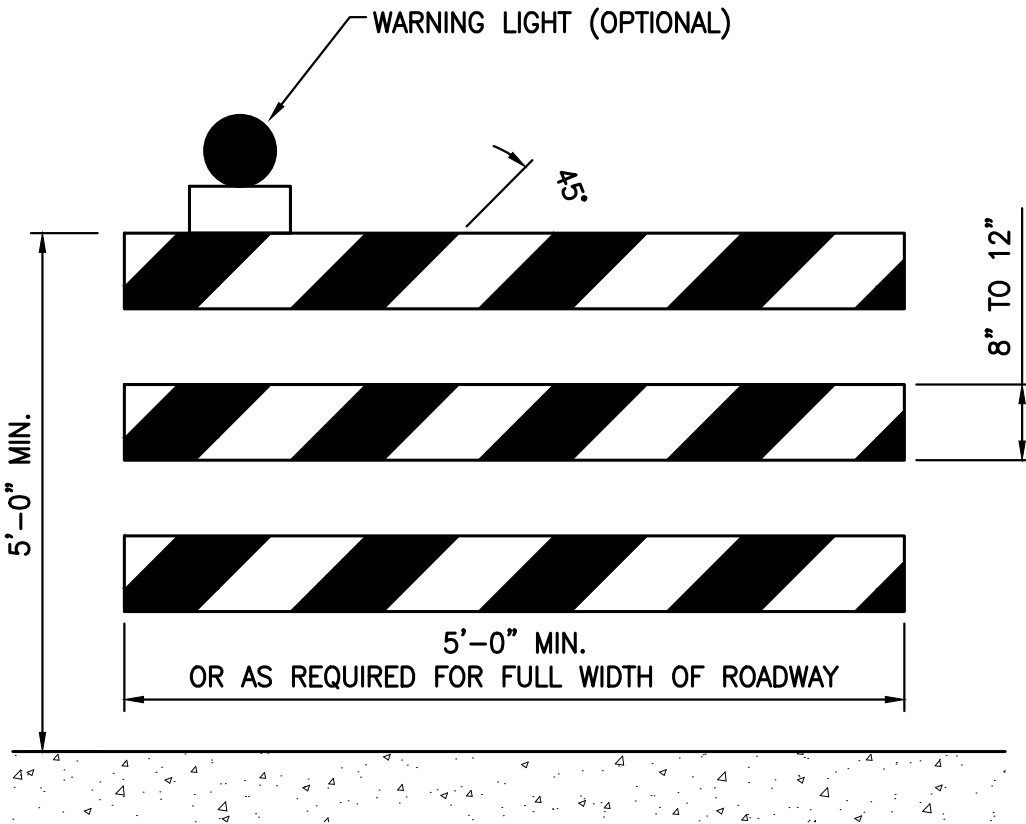

**END OF SECTION**



**NOTES:**

1. TYPE 3 BARRICADE SHALL COMPLY WITH THE MDOT SHA MANUAL OF TRAFFIC CONTROL DEVICES (MUTCD) LATEST EDITION.
2. BARRICADES MAY BE USED TO MARK ANY OF THE FOLLOWING CONDITIONS:
  - A. A ROADWAY ENDS
  - B. THE RAMP OR LANE CLOSED FOR OPERATIONAL PURPOSES, OR
  - C. THE PERMANENT OR SEMI-PERMANENT CLOSURE OR TERMINATION OF A ROADWAY.
3. WHEN USED TO WARN AND ALERT ROAD USERS OF THE TERMINUS OF A ROADWAY IN OTHER THAN TEMPORARY TRAFFIC CONTROL ZONES, BARRICADES SHALL MEET THE DESIGN CRITERIA OF MUTCD SECTION 6F.68 EXCEPT THAT THE COLOR OF THE STRIPS SHALL BE RETROREFLECTIVE WHITE AND RETROREFLECTIVE RED.
4. RAIL STRIPE WIDTHS SHALL BE 6 INCHES, EXCEPT THAT 4 INCHES WIDE STRIPES MAY BE USED IF RAIL LENGTHS ARE LESS THEN 36 INCHES. THE SIDES OF BARRICADES FACING TRAFFIC SHALL HAVE RETROREFLECTIVE RAIL FACES.
5. APPROPRIATE ADVANCE WARNING SIGNS SHOULD BE USED.

G:\Projects\2020\2010110 Town of Denton On-Call Services 2020-2025\Standards & Specs\Revised 2021 (CMB)\Manual\DETAILS\CAD\GENERAL.dwg May 04, 2021 - 3:22pm

TOWN OF DENTON DEPARTMENT OF PUBLIC WORKS	 	GENERAL DETAILS  BARRICADE	REVISED	SHEET  G-1.00
			DEC 2007	
			APR 2021	

C:\Projects\2020\200110 Town of Denton On-Call Services 2020-2025\Standards & Specs\Revised 2021 (CMB)\Manual\DETAILS\CAD\GENERAL.dwg May 04, 2021 - 3:22pm

60 WATT LED WITH LUNAR OPTICS/  
LOW CUTOFF LENSE AS SPECIFIED  
AND NOTED BELOW

NEMA TWIST LOCK  
PHOTO CONTROL  
RECEPTACLE

PROVIDE CASTING AS  
SPECIFIED (NOT SHOWN)

12' HOLOPHANE WADSWORTH SERIES 5"  
DIAMETER EXTRUDED ALUMINUM POST WITH  
FLUTED SHAFT

BOND GROUND WIRES FROM  
CIRCUIT AND FROM GROUND ROD  
TOGETHER AND TO POLE WITH  
GROUND LUG PROVIDED WITH  
POLE

1'-5" DIAMETER

24" MINIMUM

4#5 - 3" CLEAR

3/4" MINIMUM PVC CONDUIT  
CONTINUOUS BETWEEN EACH  
FIXTURE & POWER SOURCE

#5 HOOP TIES  
(4 REQUIRED)

3000 PSI CONCRETE

12'

14'-6" (NOMINAL HEIGHT)

FINISHED GRADE

ANCHOR BOLTS PER MANUFACTURERS  
SPECIFICATIONS (4 REQUIRED)

#10 BARE COPPER GROUND

CADWELD CONNECTION

3/4" DIAMETER 10'-0" COPPER  
GROUND ROD INSTALLED PER CODE

48"

18" DIA

**NOTES:**

1. DECORATIVE LUMINAIRE SHALL BE HOLOPHANE "GRANVILLE" SERIES.
2. POLE HEIGHT NOT TO EXCEED 12 FEET ABOVE GRADE.
3. FOUNDATION SHALL BE POURED ON UNDISTURBED SOIL. CONCRETE SHALL NOT BE POURED BELOW 40°F ON A FALLING TEMPERATURE.
4. LIGHT POLE ASSEMBLIES SHALL BE UNIFORMLY INSTALLED BETWEEN CURB & SIDEWALKS, OR AS DIRECTED BY ENGINEER.
5. ALL ELECTRIC INSTALLATIONS TO BE DONE BY A LICENSED ELECTRICIAN AND PER LATEST CODE REQUIREMENTS.
6. DISCONNECT SWITCH TYPE AND LOCATION PER TOWN OF DENTON APPROVAL

TOWN OF  
DENTON  
DEPARTMENT  
OF  
PUBLIC WORKS

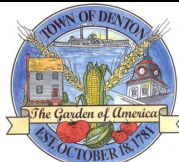

GENERAL DETAILS  
DECORATIVE STREET LIGHT  
PEDESTRIAN SCALE HEIGHT

REVISED
DEC 2007
APR 2021

SHEET  
G-2.00

C:\Projects\2020\200110 Town of Denton On-Call Services 2020-2025\Standards & Specs\Revised 2021 (CMB)\Manual\DETAILS\CAD\SANITARY SEWER.dwg May 04, 2021 - 3:22pm

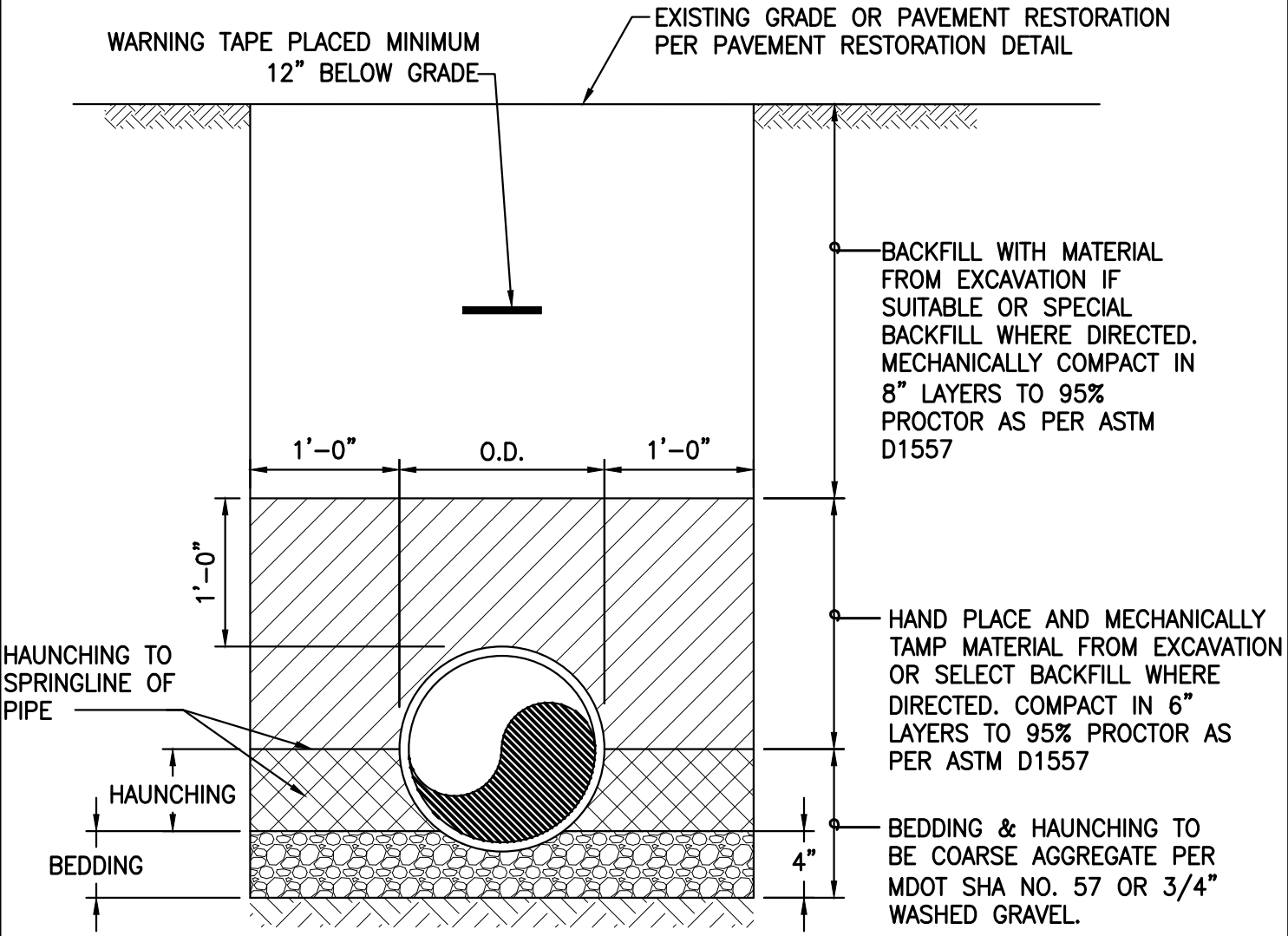

**PIPE BEDDING AND BACKFILL DETAIL**

TOWN OF  
 DENTON  
 DEPARTMENT  
 OF  
 PUBLIC WORKS

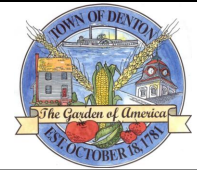

SANITARY SEWER DETAILS  
 PIPE BEDDING & BACKFILL

REVISED
DEC 2007
APR 2021

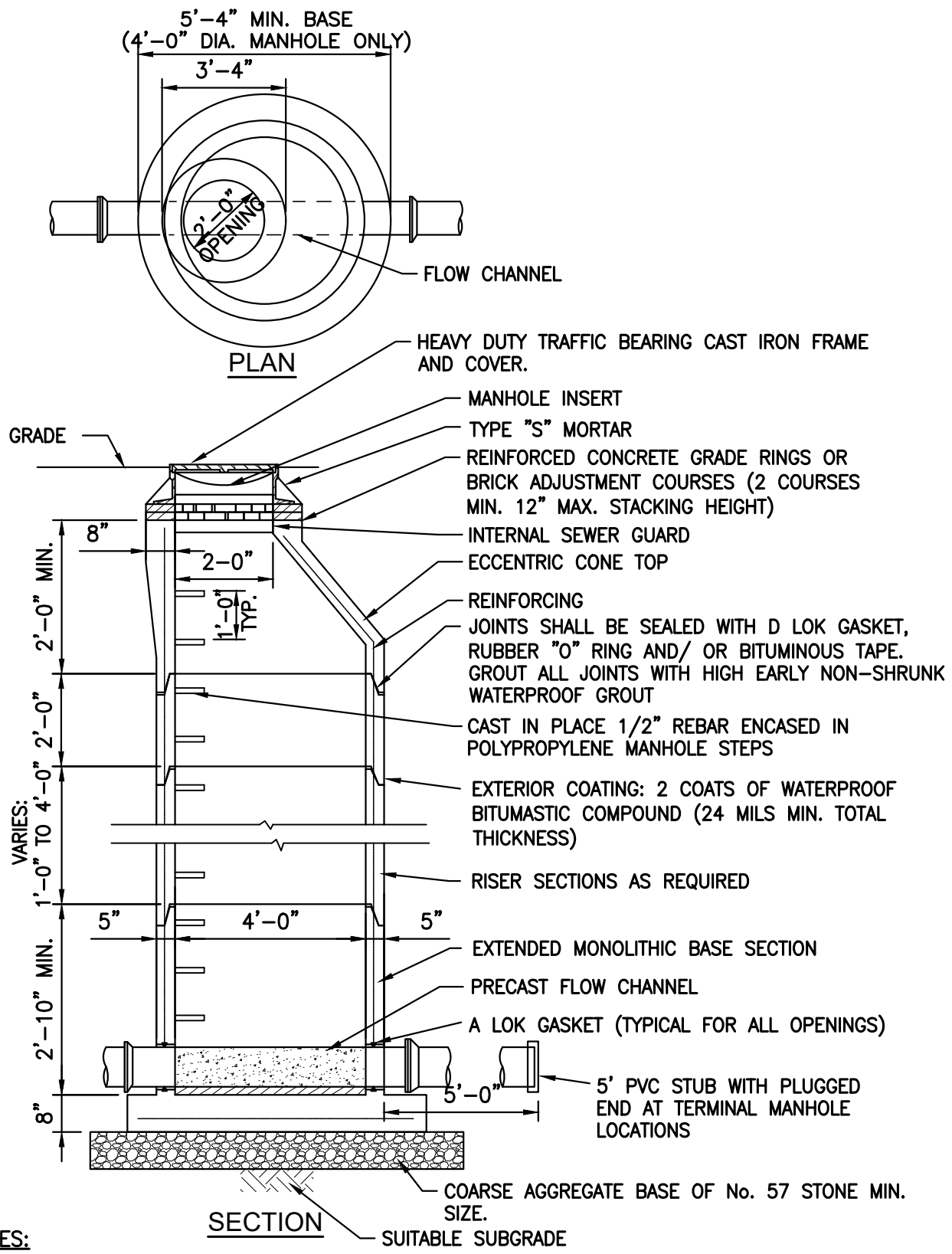

SHEET  
 SS-1.00

G:\Projects\2020\200110 Town of Denton On-Call Services 2020-2025 Standards & Specs Revised 2021 (CHB)\Manual\DETAILS\CAD\SANITARY SEWER.dwg May 04, 2021 - 3:22pm

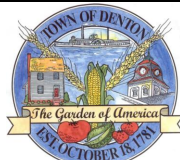

**NOTES:**

1. MANHOLE SHALL CONFORM TO ASTM C-478, LATEST REVISION.
2. PARGE ALL JOINTS WITH TYPE "S" NON-SHRINK GROUT.

TOWN OF DENTON DEPARTMENT OF PUBLIC WORKS	 	SANITARY SEWER DETAILS PRECAST CONCRETE MANHOLE	REVISED	SHEET
			DEC 2007	
			APR 2021	
			SS-2.00	



G:\Projects\2020\200110 Town of Denton On-Call Services 2020-2025\Standards & Specs\Revised 2021 (CHB)\Manual\DETAILS\CAD\SANITARY SEWER.dwg May 04, 2021 - 3:22pm

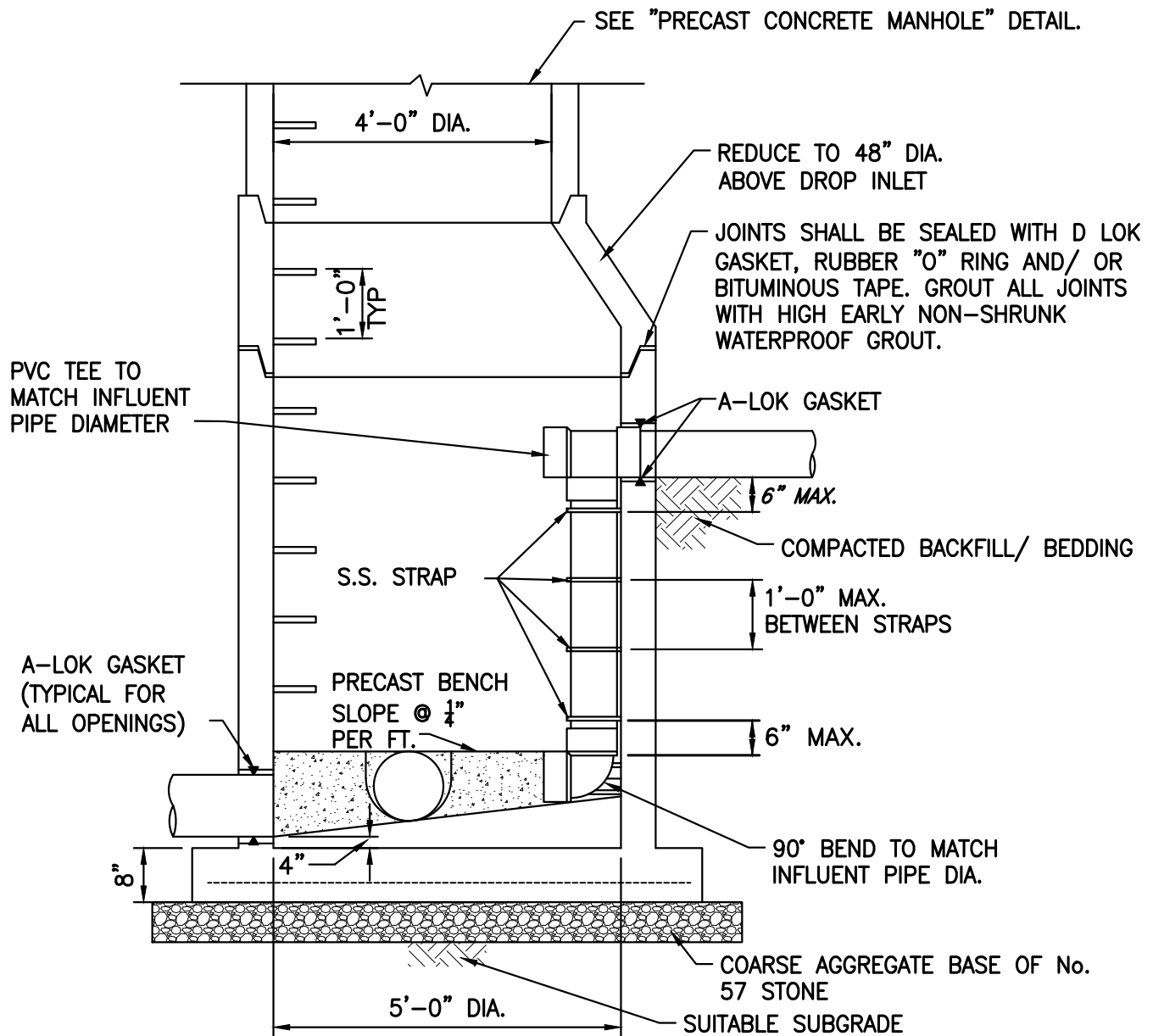

**NOTES:**

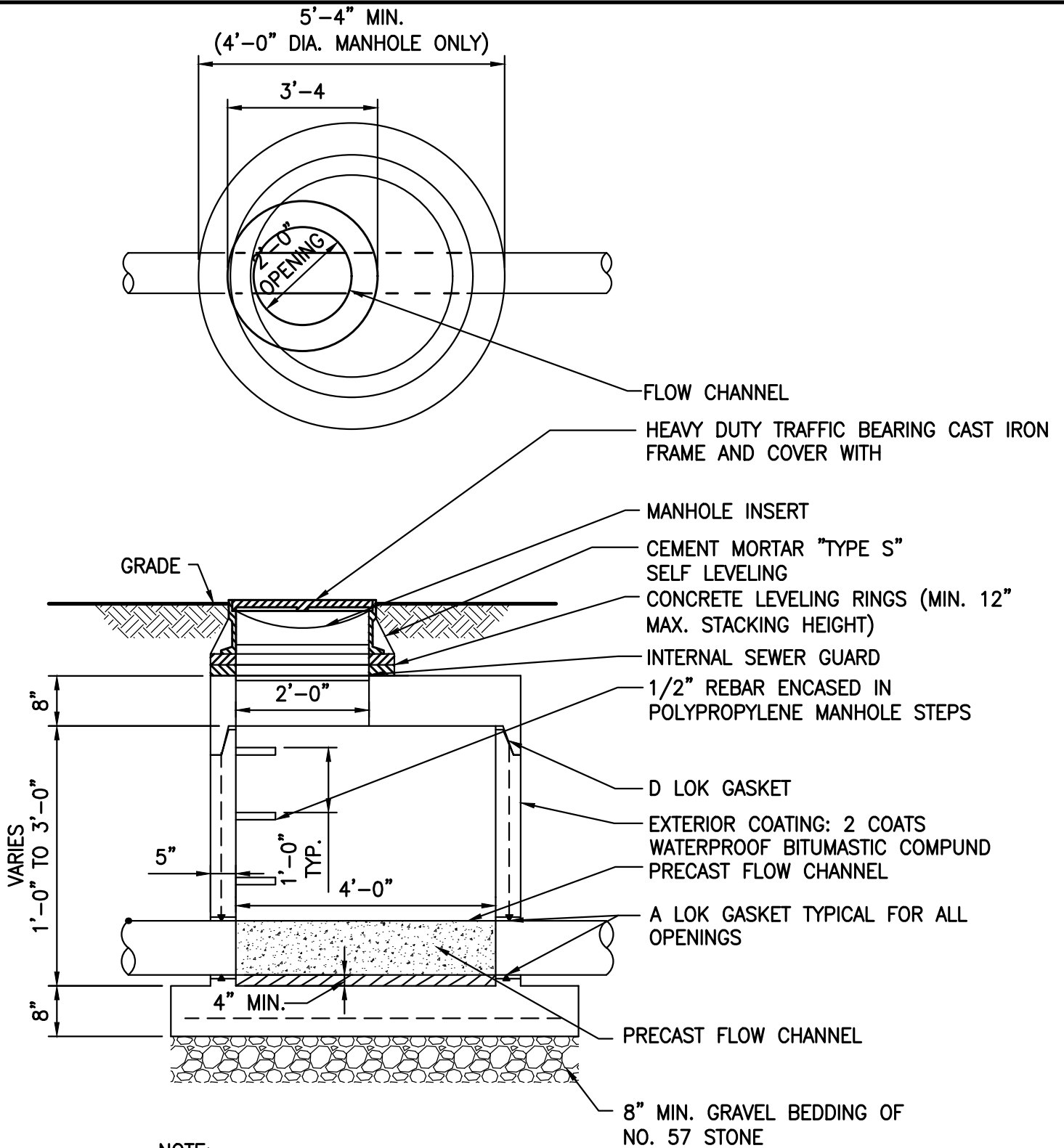

1. STAINLESS STEEL STRAPS SHALL BE 1/8"x1" MINIMUM.
2. S.S. STRAP CONNECTORS SHALL BE EXPANSION BOLTS OR APPROVED EQUAL.
3. PARGE ALL JOINTS WITH TYPE "S" NON-SHRINK GROUT

<p>TOWN OF DENTON DEPARTMENT OF PUBLIC WORKS</p>			SANITARY SEWER DETAILS	REVISED	SHEET
			PRECAST CONCRETE INSIDE	DEC 2007	
			DROP MANHOLE		
			SS-2.10		



**NOTE:**

1. MANHOLE SHALL CONFORM TO ASTM C-478
2. DETAIL APPLIES TO SANITARY SEWER AND STORM WATER MANHOLES

<p>TOWN OF DENTON DEPARTMENT OF PUBLIC WORKS</p>  	<p>SANITARY SEWER DETAIL SHALLOW PRECAST MANHOLE</p>	REVISED	SHEET
		DEC 2007	
		SS-2.20	

G:\Projects\2020\20110 Town of Denton On-Call Services 2020-2025\Standards & Specs\Revised 2021 (CHB)\Manual\DETAILS\CAD\SANITARY SEWER.dwg May 04, 2021 - 3:23pm

WALL AREA BETWEEN EXISTING PIPE AND DOGHOUSE OPENINGS SHALL BE FILLED WITH BRICK AND NON-SHRINK MORTAR.

REMOVE TOP HALF OF EXISTING PIPE AFTER COMPLETION OF BRICK CHANNEL WORK.

EXTERIOR COATING:  
2 COATS OF WATERPROOF BITUMASTIC COMPOUND (24 MILS MIN TOTAL THICKNESS)

BRICK OR HAND FORMED CONCRETE FLOW CHANNELS  
SLOPE 1/4" PER 1FT

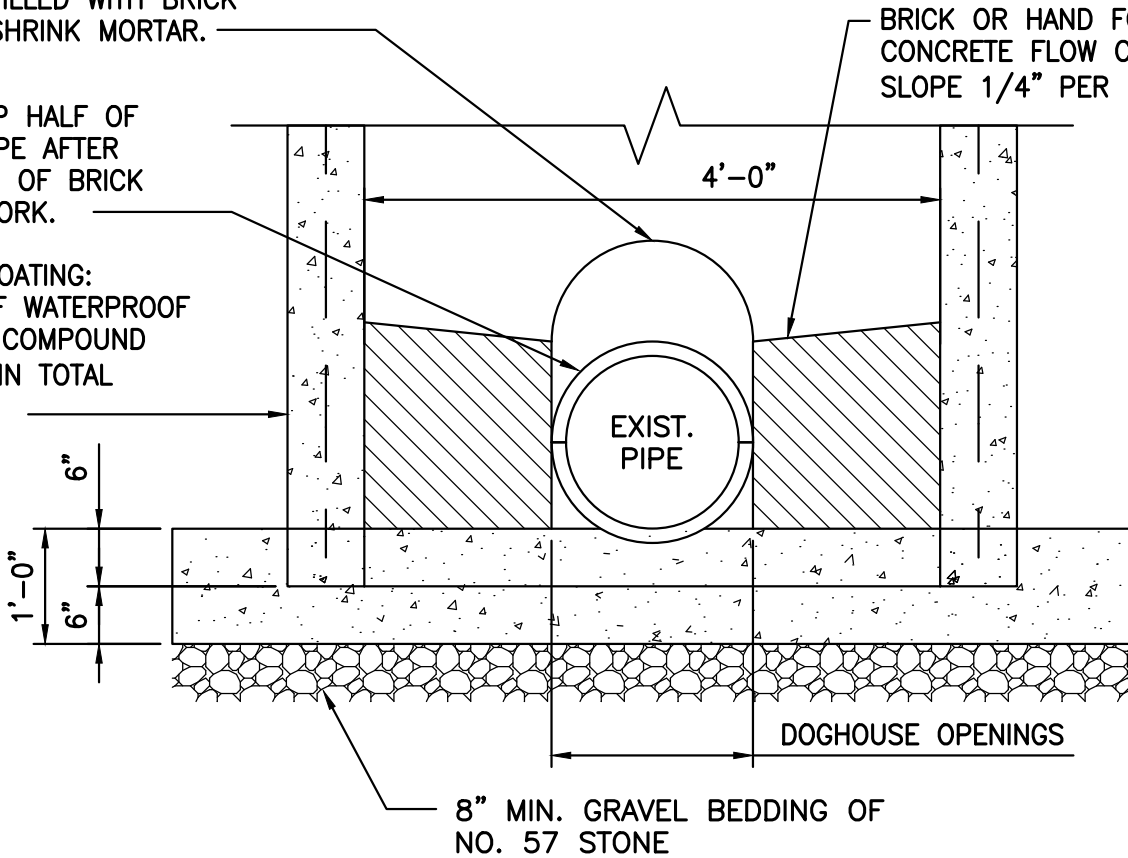

NOTE: MANHOLE SHALL CONFORM TO ASTM C-478, LATEST EDITION

DOGHOUSE MANHOLE

<p>TOWN OF DENTON DEPARTMENT OF PUBLIC WORKS</p>			<p>SANITARY SEWER DETAILS</p>	<p>REVISED</p>	<p>SHEET</p>
			<p>ALTERNATE MANHOLE BASE</p>	<p>DEC 2007</p>	<p>SS-2.30</p>
			<p>(DOG HOUSE MANHOLE)</p>		

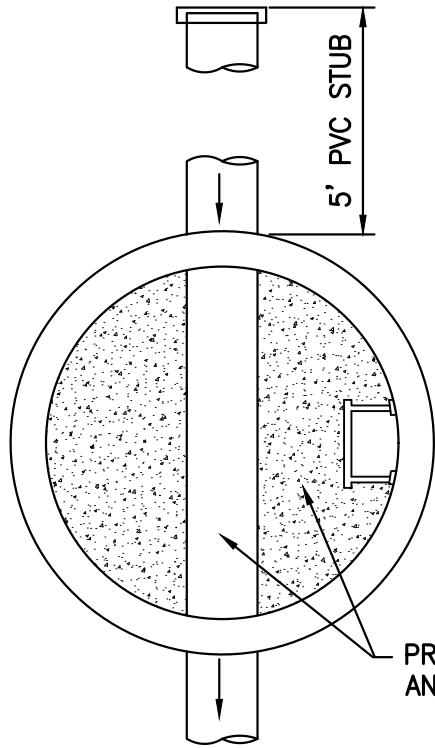

TERMINAL

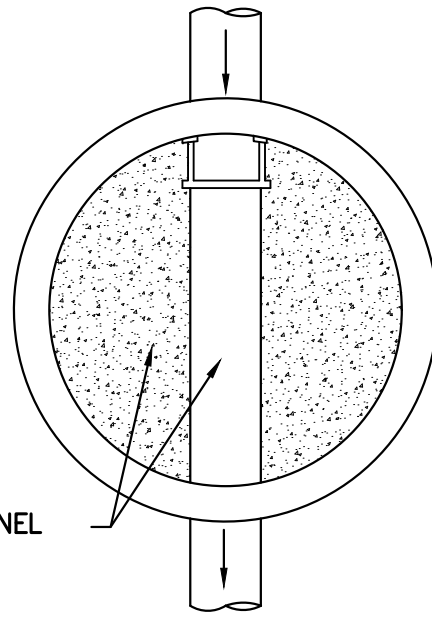

1-WAY

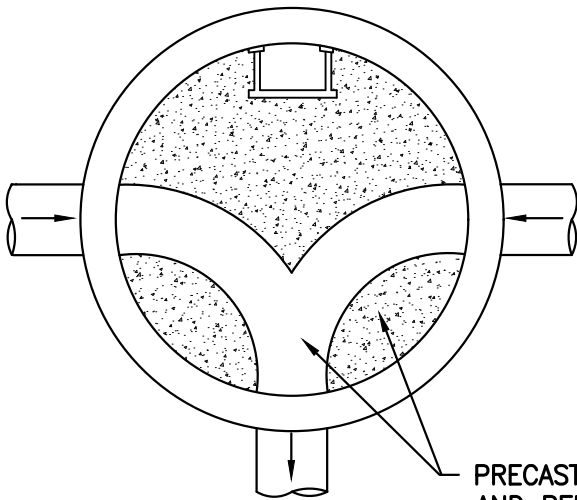

2-WAY

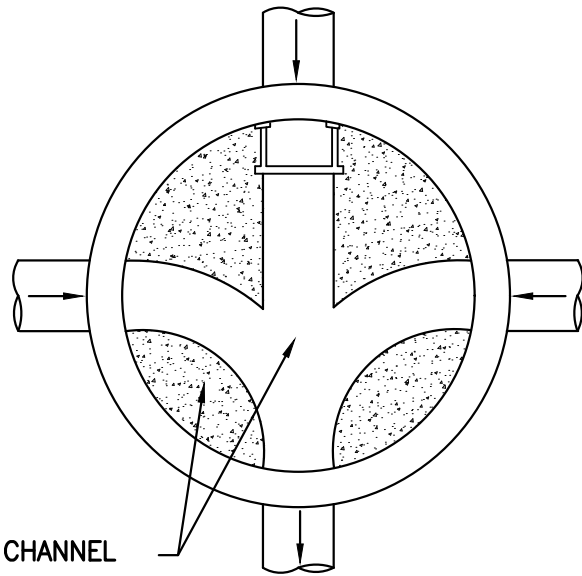

3-WAY

PRECAST FLOW CHANNEL AND BENCH

PRECAST FLOW CHANNEL AND BENCH

TOWN OF  
DENTON  
DEPARTMENT  
OF  
PUBLIC WORKS



SANITARY SEWER DETAILS  
MANHOLE  
FLOW CHANNEL

REVISED	SHEET SS-2.40
DEC 2007	

"STORM DRAIN" OR  
 "SANITARY SEWER" CAST  
 IN COVER AS  
 APPLICABLE

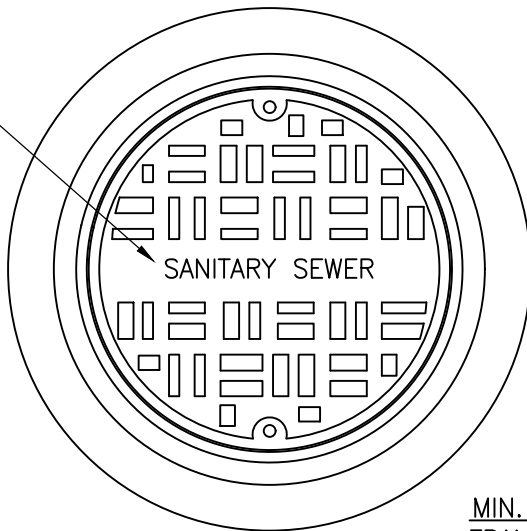

EAST JORDAN (SHOWN)  
 FRAME #154514  
 COVER #154524 (STORM DRAIN)  
 COVER #154523 (SANITARY SEWER)  
 NEENAH FOUNDRY  
 FRAME R-1565  
 COVER R-1564  
 OR APPROVED SUBSTITUTE

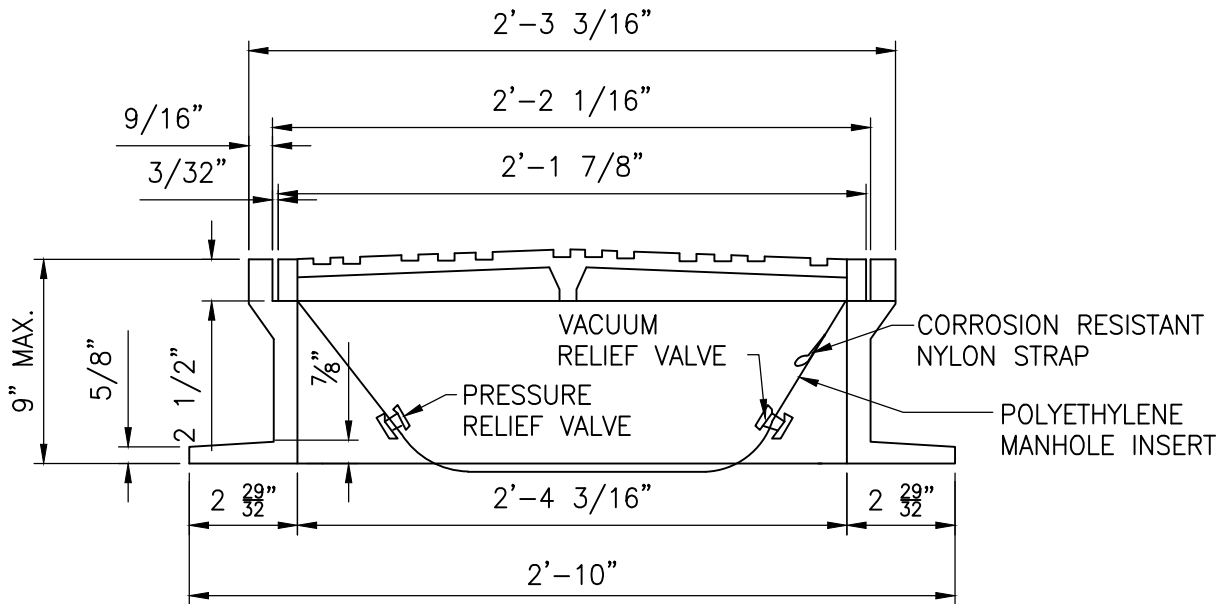

MIN.	AVG.	WEIGHT
FRAME	250	LBS.
COVER	189	LBS.
(HEAVY DUTY, TRAFFIC BEARING)		



**NOTES:**

1. CASTINGS SHALL CONFORM TO ASTM A-48, LATEST EDITION, CLASS 35B IRON MINIMUM.
2. PICK HOLES REQUIRED WITHIN COVER.
3. MANHOLE INSERT PARSON MODEL V2P AS MANUFACTURED BY PARSON ENVIRONMENTAL PRODUCTS OR APPROVED EQUAL. MANHOLE INSERT TO BE USED AT SANITARY SEWER MANHOLES ONLY.

G:\Projects\2020\200110 Town of Denton On-Call Services 2020-2025\Standards & Specs\Revised 2021 (OMB)\Manual\DETAILS\CAD\SANITARY SEWER.dwg May 02, 2023 - 9:41am

TOWN OF DENTON DEPARTMENT OF PUBLIC WORKS	 	SANITARY SEWER DETAILS  MANHOLE FRAME AND COVER	REVISED	SHEET  SS-2.50
			DEC. 2007	
			APR 2021	

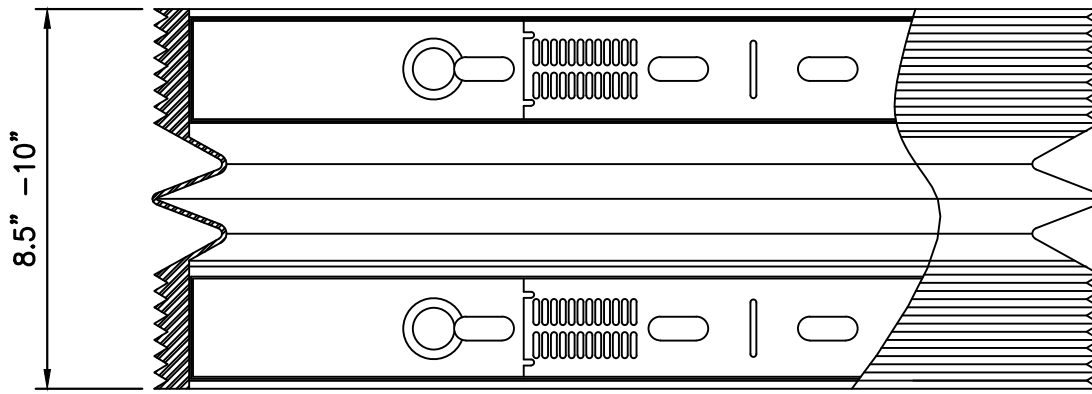

SEWER GUARD (INTERNAL)

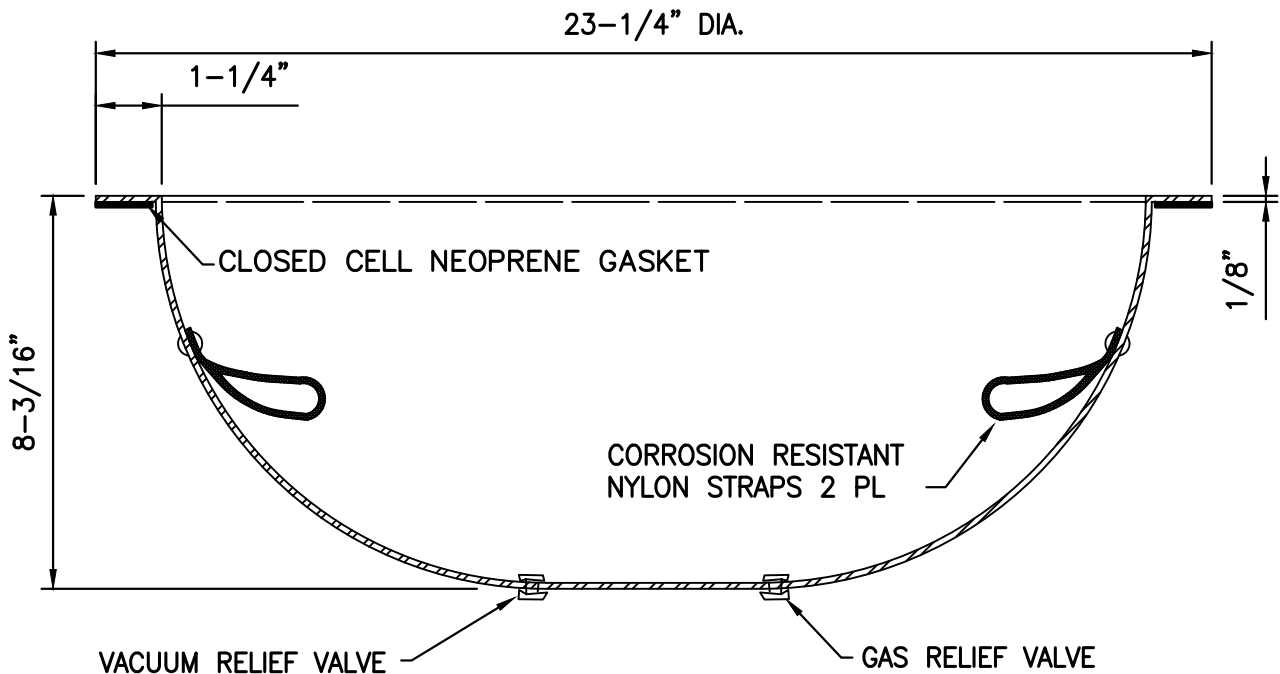



MANHOLE INSERT

**NOTES:**

1. MANHOLE INSERT MODEL V2P AS MANUFACTURED BY PARSON ENVIRONMENTAL PRODUCTS, WERNERSVILLE, PA. 19606, OR AN APPROVED EQUAL.
2. INTERNAL SEWER GUARD MODEL FLEXIRIB SEAL AS MANUFACTURED BY PARSON ENVIRONMENTAL PRODUCTS, WERNERSVILLE, PA 19606, OR AS APPROVED EQUAL.
3. MANHOLE INSERT AND SEWER GUARD SEAL TO BE USED IN ALL SANITARY SEWER MANHOLES TO ELIMINATE INFLOW AT MANHOLE FRAME – STRUCTURE INTERFACE.

G:\Projects\2020\20110 Town of Denton On-Call Services 2020-2025\Standards & Specs\Revised 2021 (CHB)\Manual\DETAILS\CAD\SANITARY SEWER.dwg May 04, 2021 - 3:23pm

TOWN OF DENTON DEPARTMENT OF PUBLIC WORKS	 	SANITARY SEWER DETAILS  MANHOLE INSERT AND FRAME-CHIMNEY SEAL	REVISED	SHEET  SS-2.60
			DEC 2007	
			APR 2021	



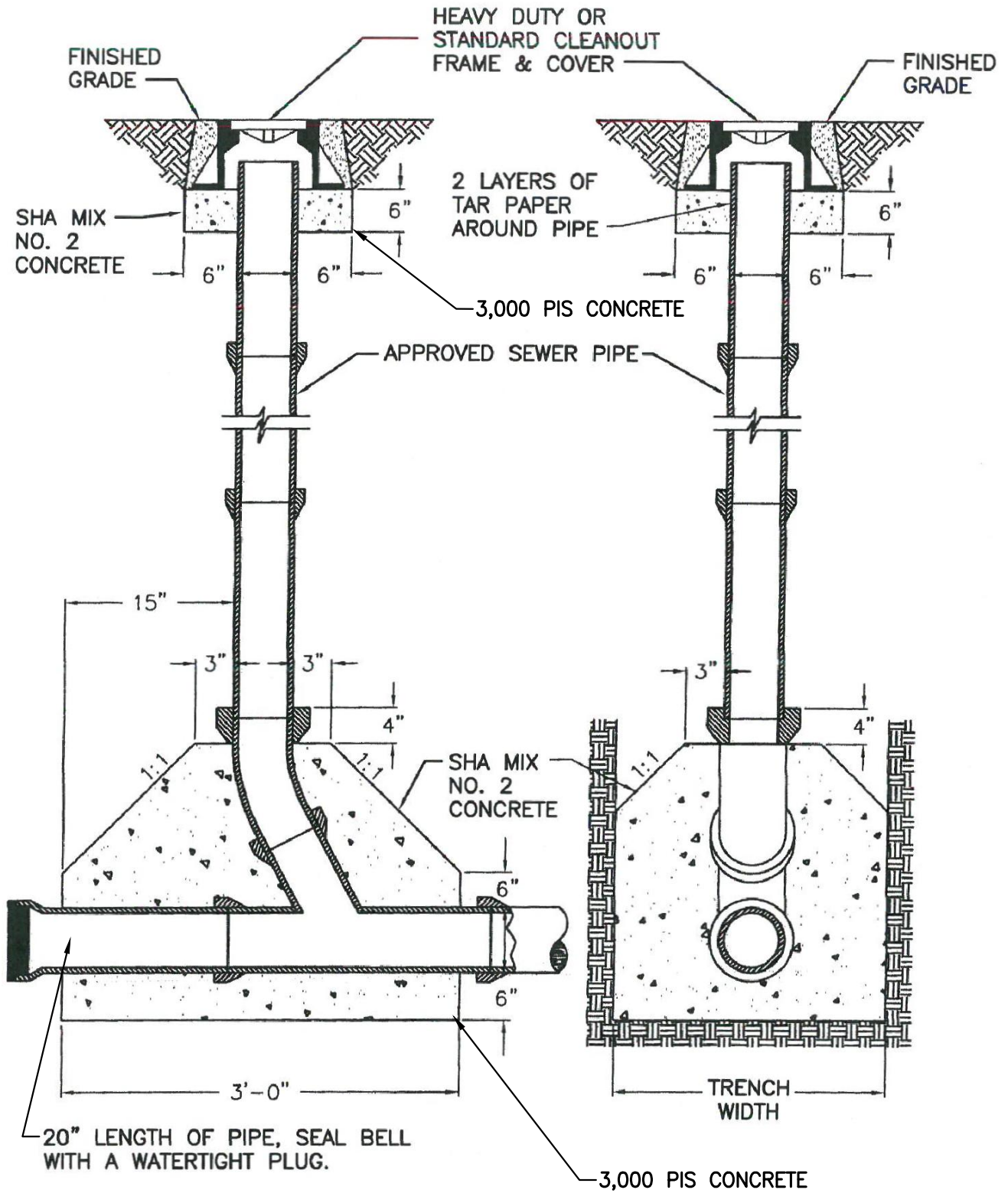

**NOTES:**

1. ADD WARNING TAPE TO ALL PIPES.

G:\Projects\2020\20110 Town of Denton On-Call Services 2020-2025\Standards & Specs\Revised 2021 (CHB)\Manual\DETAILS\CAD\SANITARY SEWER.dwg May 04, 2021 - 3:23pm

TOWN OF DENTON DEPARTMENT OF PUBLIC WORKS	 	SANITARY SEWER DETAILS MAINLINE CLEANOUT	REVISED	SHEET  SS-3.00
			DEC 2007	
			APR 2021	

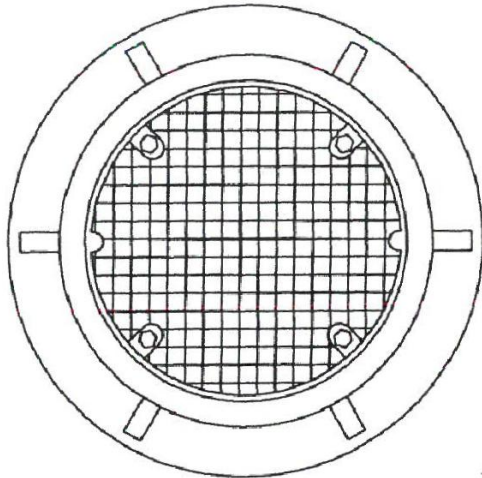

Plan

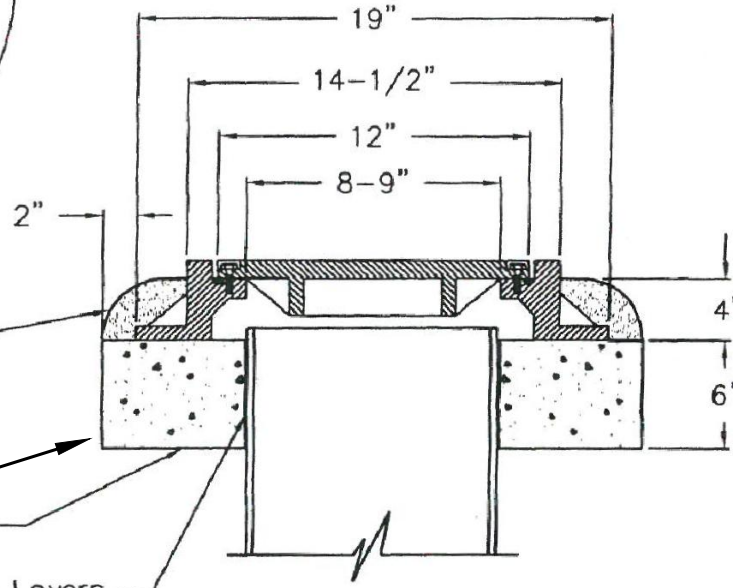

Section

Grout Inplace With  
Non-Shrinking, High  
Early, Waterproof  
Grout.

**3000PSI CONCRETE**

SHA Mix No. 2 Conc.

Wrap Pipe With 2 Layers  
Of Tar Paper Before  
Placing Conc.

NOTES:

1. CASTINGS SHALL CONFORM TO ASTM A-48 LATEST EDITION, CLASS 35 IRON MINIMUM.
2. CASTINGS SHALL HAVE GROUND OR MACHINED BEARING SURFACES.
3. CASTINGS SHALL BE OF UNIFORM QUALITY, FREE FROM BLOW HOLES, POROSITY, HARD SPOTS, SHRINKAGE DEFECTS, OR OTHER INJURIOUS DEFECTS.
4. CASTING SHALL BE HEAVY DUTY ROADWAY TYPE.
5. FRAME & COVER SHALL BE EJIW MODEL 1566 FOR 6" OR 1564 FOR 8" AS MANUFACTURED BY EAST JORDEN IRON WORKS, EAST JORDEN, MI. OR AN APPROVED EQUAL.

TOWN OF  
DENTON  
DEPARTMENT  
OF  
PUBLIC WORKS



SANITARY SEWER DETAILS  
WATERTIGHT MAINLINE CLEANOUT  
FRAME & COVER

REVISED  
DEC 2007  
APR 2021

SHEET  
SS-3.10



G:\Projects\2020\20110 Town of Denton On-Call Services 2020-2025\Standards & Specs\Revised 2021 (CHB)\Manual\DETAILS\CAD\SANITARY SEWER.dwg May 04, 2021 - 3:23pm

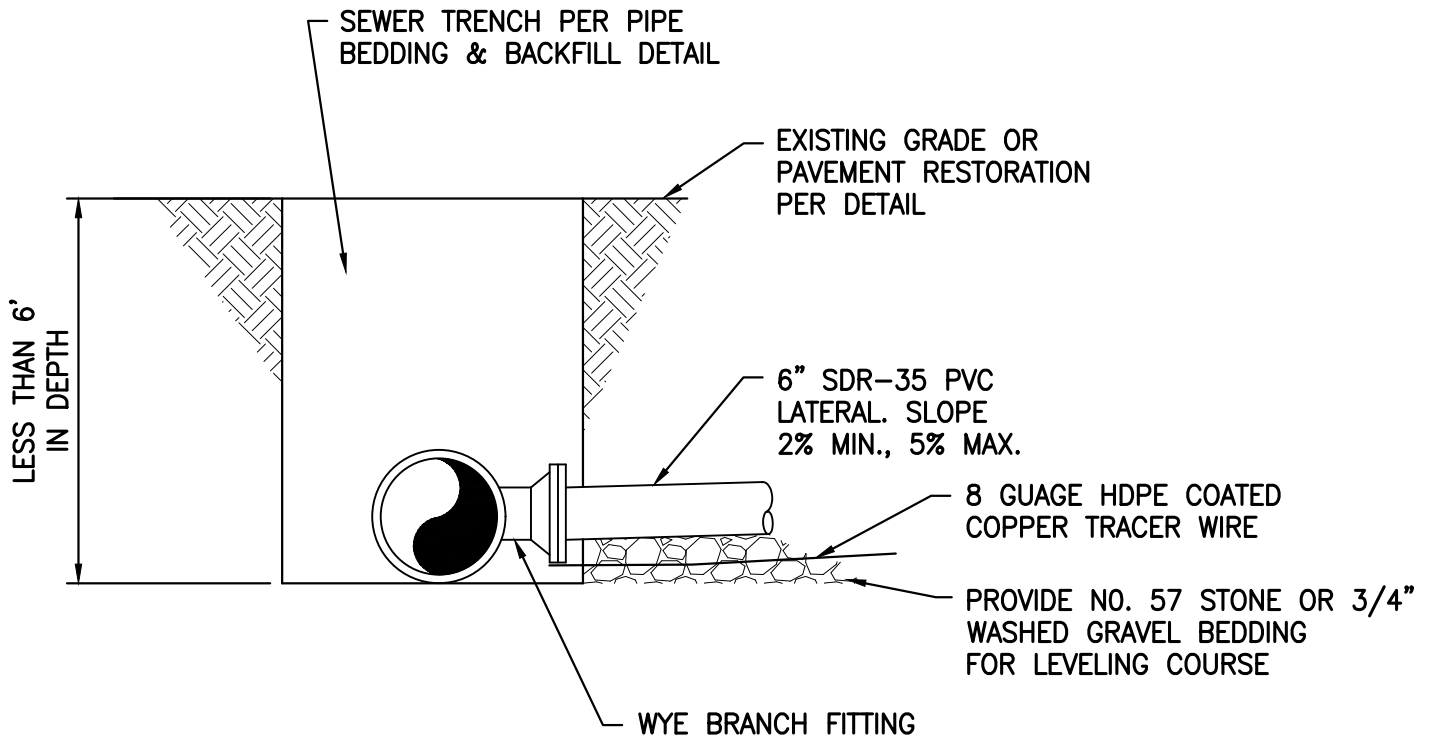

SHALLOW MAIN

NOTES:

1. ADD WARNING TAPE 12" MINIMUM BELOW GRADE ABOVE LATERAL FROM MAIN TO HOUSE.
2. SEE CLEAN OUT DETAILS FOR CONTINUATION.

<p>TOWN OF DENTON DEPARTMENT OF PUBLIC WORKS</p>		 <p>DENTON PUBLIC WORKS</p>	SANITARY SEWER DETAILS	REVISED	<p>SHEET  SS-4.00</p>
			STANDARD HOUSE CONNECTIONS	DEC 2007	
			SHALLOW MAIN	APR 2021	

G:\Projects\2020\2010110 Town of Denton On-Call Services 2020-2025\Standards & Specs\Revised 2021 (CHB)\Manual\DETAILS\CAD\SANITARY SEWER.dwg May 04, 2021 - 3:23pm

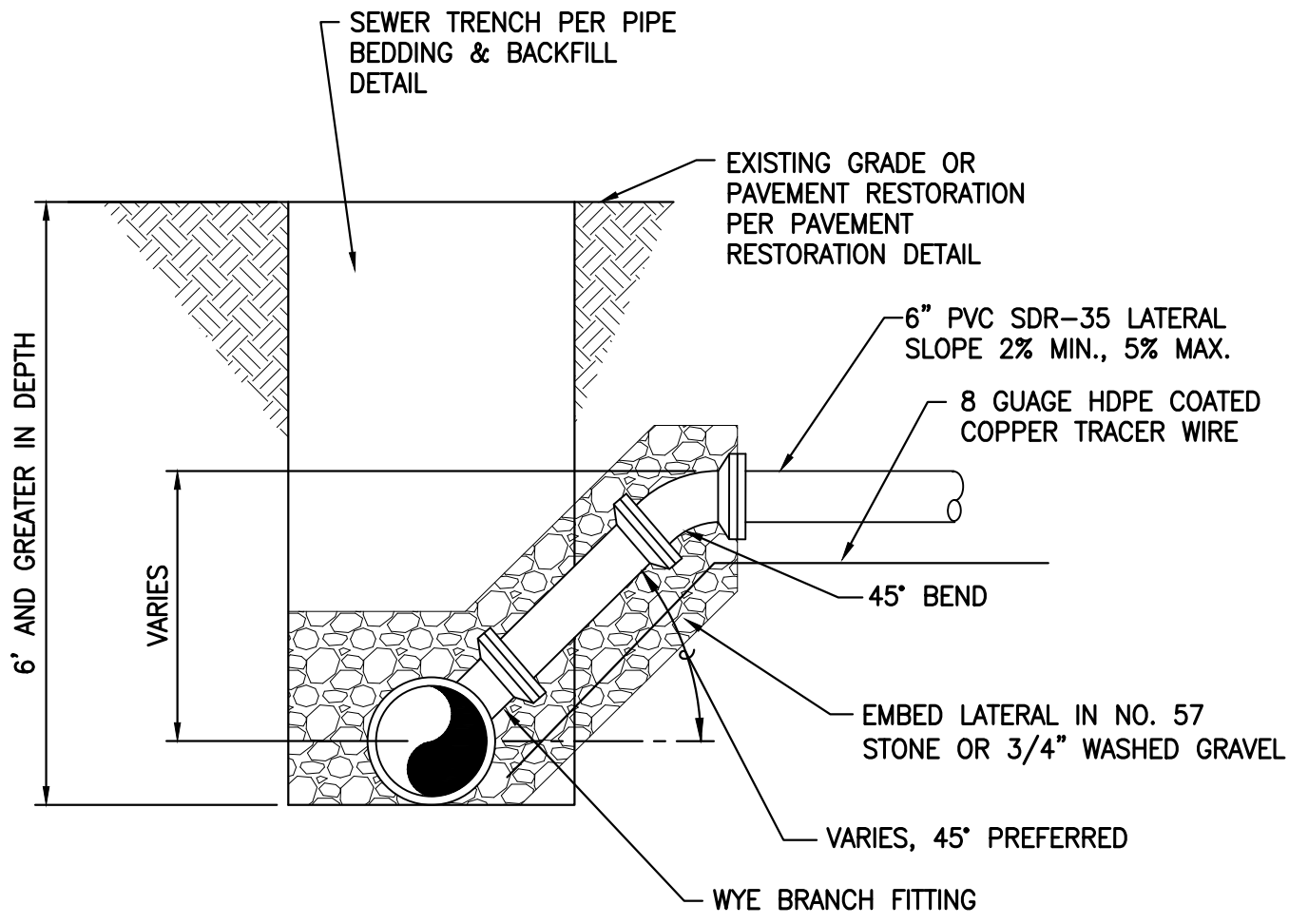

DEEP MAIN

**NOTES:**

1. ADD WARNING TAPE 12" MINIMUM BELOW GRADE ABOVE LATERAL FROM MAIN TO HOUSE.
2. SEE CLEAN OUT DETAILS FOR CONTINUATION.

TOWN OF DENTON DEPARTMENT OF PUBLIC WORKS			SANITARY SEWER DETAILS	REVISED	SHEET  SS-4.10
			STANDARD HOUSE CONNECTIONS	DEC 2007	
			DEEP MAIN	APR 2021	

G:\Projects\2020\20110 Town of Denton On-Call Services 2020-2025\Standards & Specs\Revised 2021 (CHB)\Manual\DETAILS\CAD\SANITARY SEWER.dwg May 04, 2021 - 3:23pm

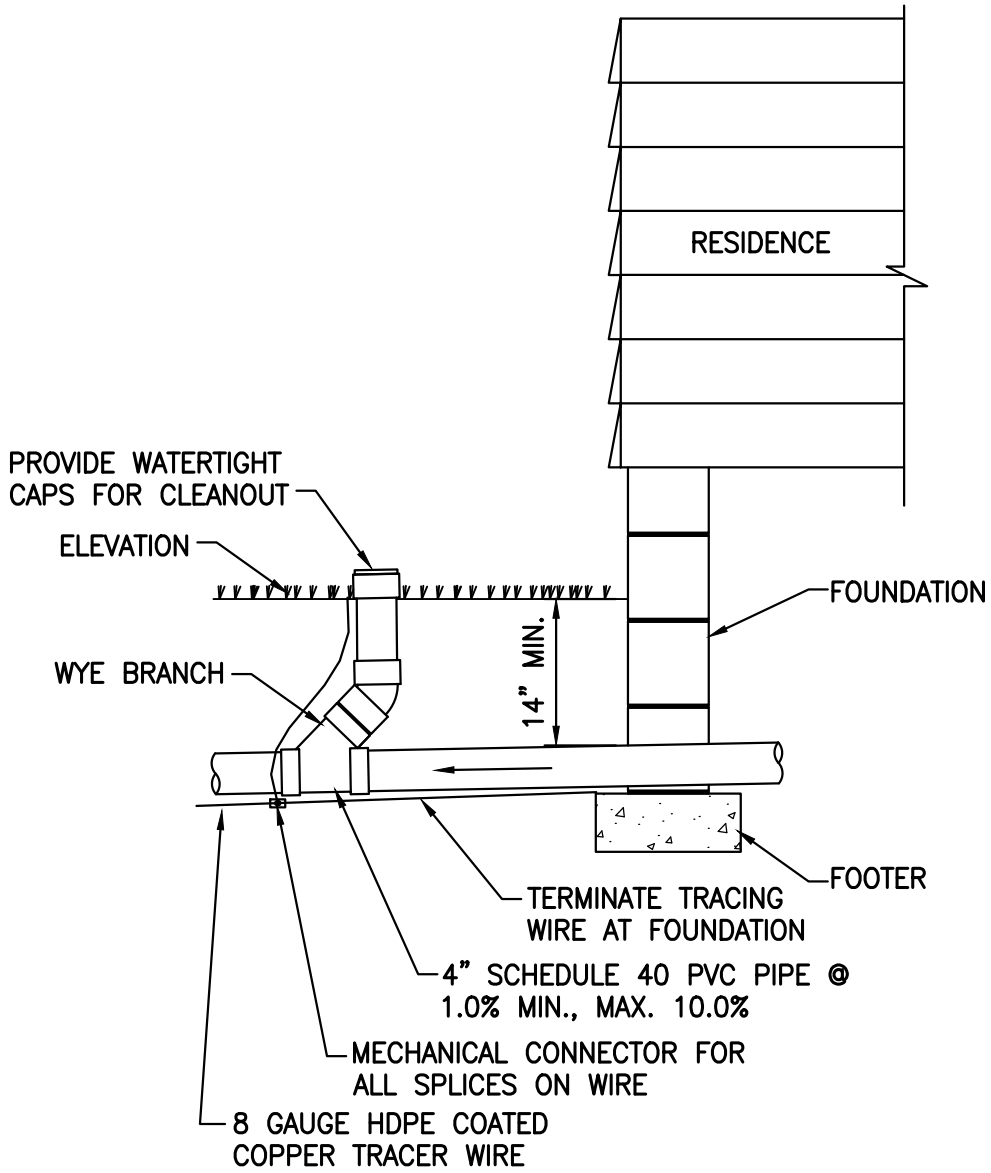

TOWN OF  
DENTON  
DEPARTMENT  
OF  
PUBLIC WORKS

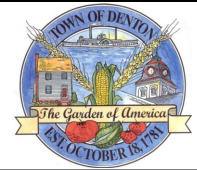

SANITARY SEWER DETAILS  
HOUSE CONNECTION

REVISED	SHEET SS-5.00
DEC 2007	
APR 2021	

G:\Projects\2020\200110 Town of Denton On-Call Services 2020-2025\Standards & Specs\Revised 2021 (CHB)\Manual\DETAILS\CAD\SANITARY SEWER.dwg May 04, 2021 - 3:23pm

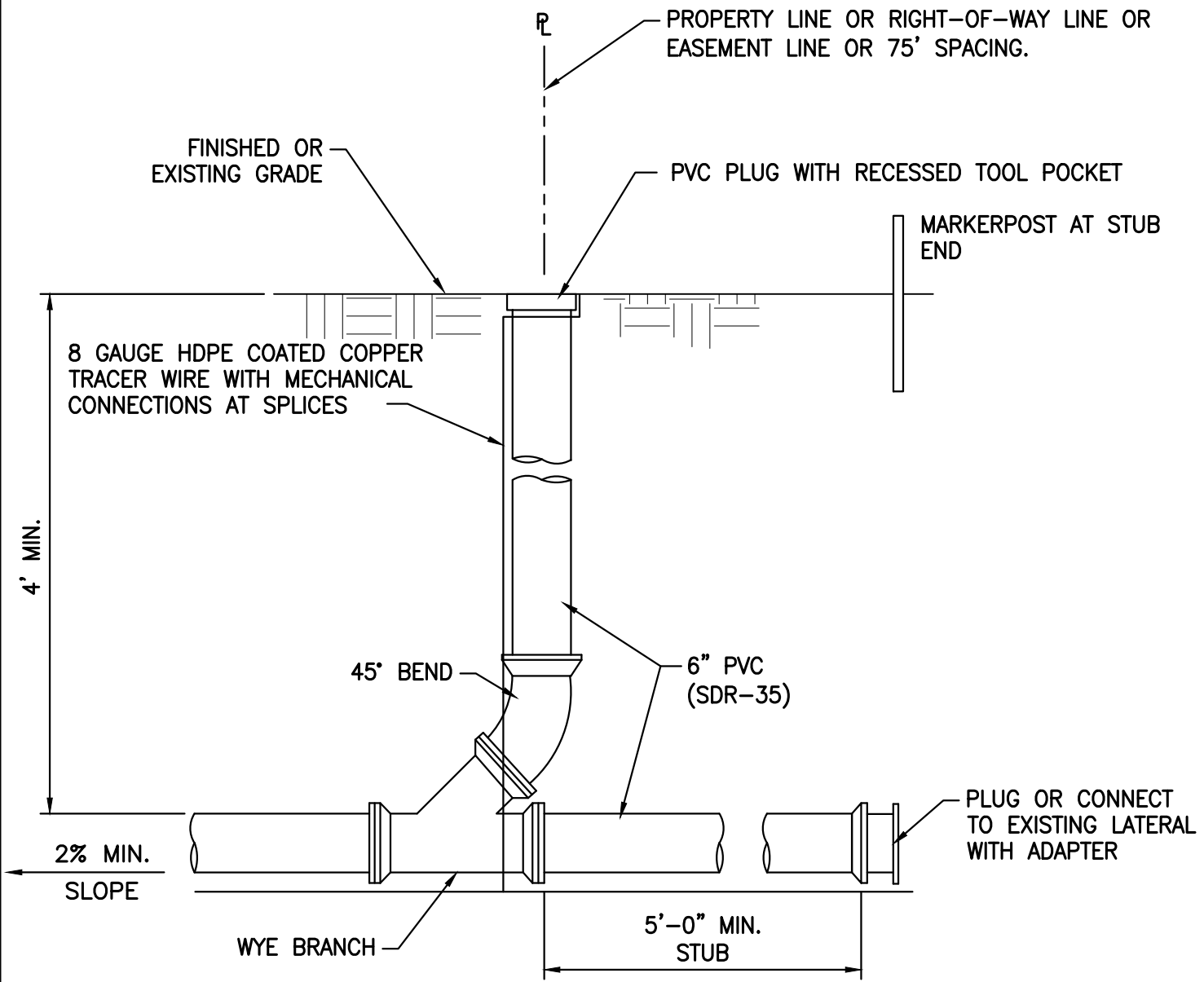

**NOTES:**

1. C.O. NOT TO BE LOCATED IN DITCH, SWALE, ETC.
2. MAINTAIN 10' MIN. SEPARATION BETWEEN WATER AND SEWER LINES.
3. SEE HOUSE CONNECTION DETAIL FOR CONTINUATION.
4. ADD WARNING TAPE 12" MINIMUM BELOW GRADE ABOVE LATERAL FROM MAIN TO STRUCTURE.

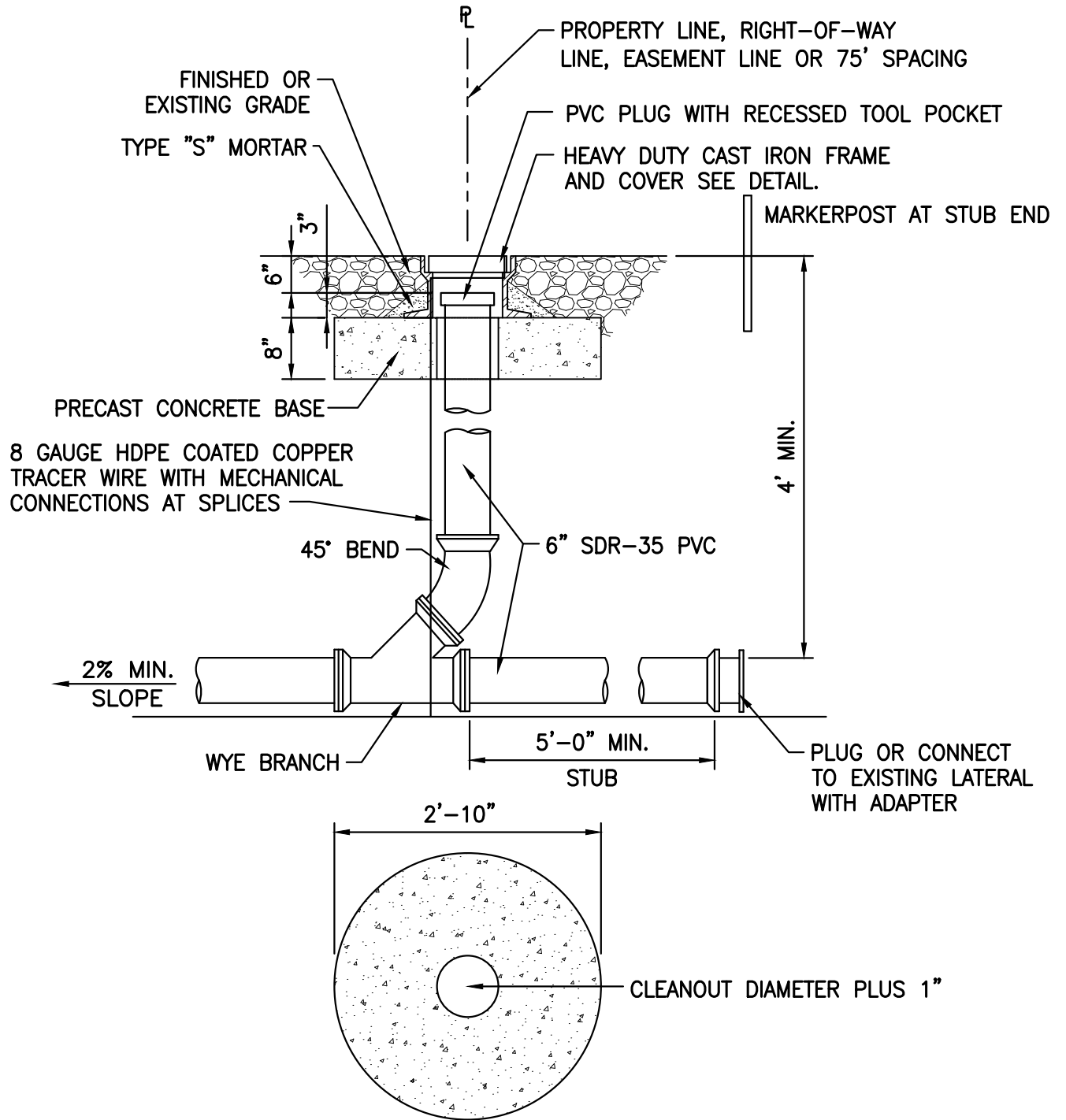

<p>TOWN OF DENTON DEPARTMENT OF PUBLIC WORKS</p>			SANITARY SEWER DETAILS	REVISED	SHEET
			LATERAL CLEANOUT	DEC 2007	
			FOR GRASS AREAS	APR 2021	
				SS-5.10	



### PRECAST CONCRETE BASE PLAN

**NOTES:**

1. C.O. NOT TO BE LOCATED IN DITCH, SWALE, ETC.
2. MAINTAIN 10' MIN. SEPARATION BETWEEN WATER AND SEWER LINES.
3. SEE HOUSE CONNECTION DETAIL FOR CONTINUATION.
4. ADD WARNING TAPE 12" MINIMUM BELOW GRADE ABOVE LATERAL FROM MAIN TO STRUCTURE.

TOWN OF DENTON DEPARTMENT OF PUBLIC WORKS			SANITARY SEWER DETAILS	REVISED	SHEET
			LATERAL CLEANOUT	DEC 2007	
			FOR TRAFFIC AREAS	APR 2021	
			SS-5.20		

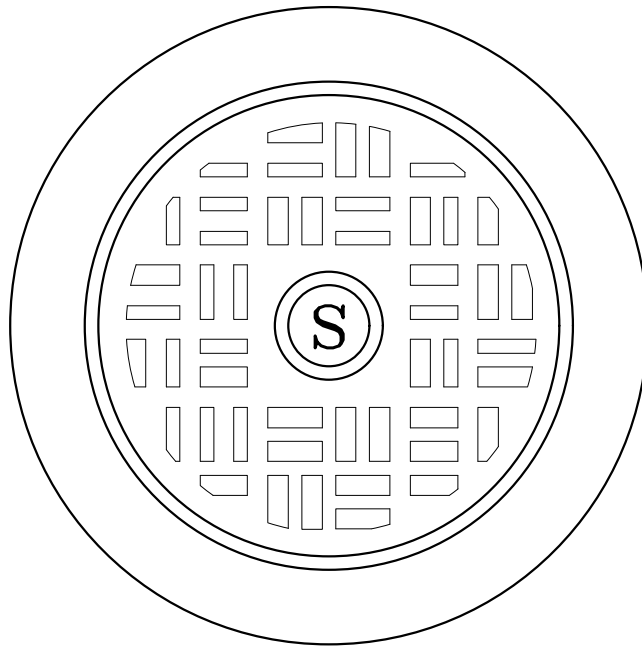

PLAN

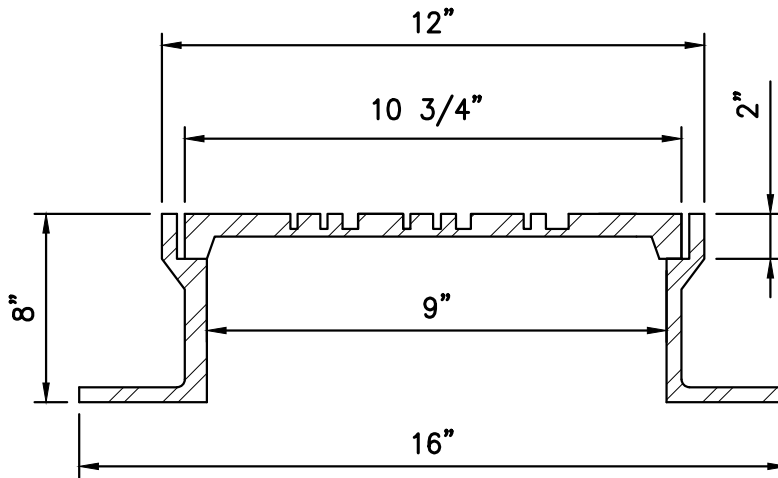



SECTION

MATERIAL – CAST IRON ASTM-A-48 CLASS 35  
 WEIGHT – APPROX. 130 LBS.

NOTES:

FOR USE WITH TRAFFIC BEARING SANITARY SEWER LATERAL CLEANOUT.

G:\Projects\2020\200110 Town of Denton On-Call Services 2020-2025\Standards & Specs\Revised 2021 (CHB)\Manual\DETAILS\CAD\SANITARY SEWER.dwg May 04, 2021 - 3:23pm

TOWN OF DENTON DEPARTMENT OF PUBLIC WORKS	 	SANITARY SEWER DETAILS HEAVY DUTY CLEANOUT FRAME AND COVER	REVISED	SHEET SS-6.00
			DEC 2007	
			APR 2021	

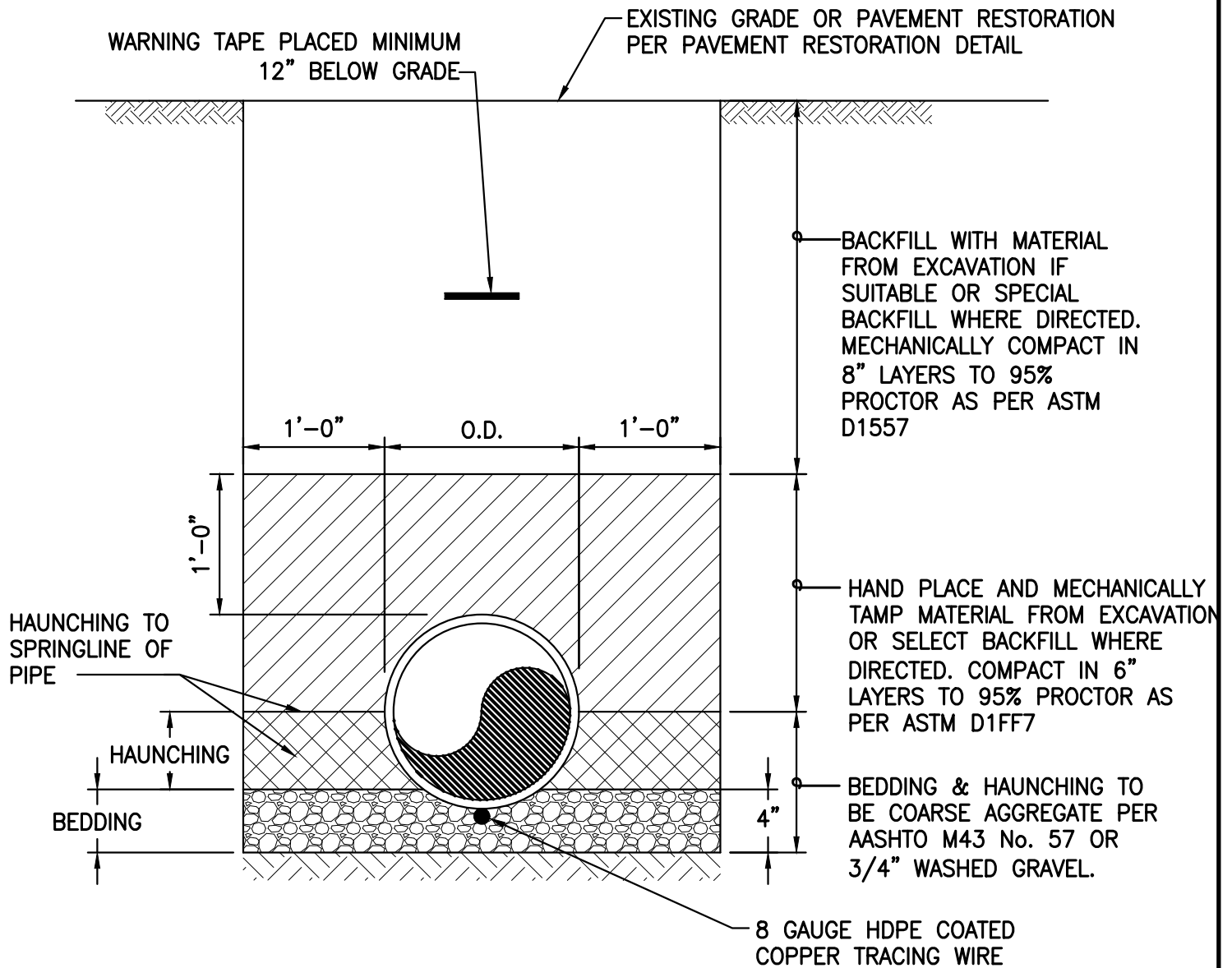

C:\Projects\2020\20110 Town of Denton On-Call Services 2020-2025 Standards & Specs Revised 2021 (CHB)\Manual\DETAILS\CAD\SANITARY SEWER.dwg May 04, 2021 - 3:24pm



**PIPE BEDDING AND BACKFILL DETAIL**

**NOTES:**

1. WARNING TAPE SHALL BE PLACED 24" ABOVE ALL PIPE OR MIN. 12" BELOW GRADE.
2. THE 8 GAUGE HDPE COATED COPPER TRACING WIRE SHALL BE A CONTINUOUS CONDUCTOR.
3. ALL FITTINGS SHALL BE AS SPECIFIED IN AWWA C110 MECHANICAL JOINT, DUCTILE IRON, PRESSURE RATED AT 350 PSI.
4. ALL FITTINGS SHALL BE RESTRAINED BY THRUST BLOCKS ACCORDING TO STANDARD DETAILS.
5. FIRM BEARING SHALL BE PROVIDED FOR FULL LENGTH OF BARREL. EXCAVATED FOR BELL HOLES.
6. ALL FM VALVES OPEN COUNTER-CLOCKWISE.

TOWN OF DENTON DEPARTMENT OF PUBLIC WORKS	 	SANITARY SEWER DETAILS PVC FORCE MAIN INSTALLATION	REVISED	SHEET
			DEC 2007	
			APR 2021	
			SS-7.00	

C:\Projects\2020\200110 Town of Denton On-Call Services 2020-2025 Standards & Specs Revised 2021 (CHB)\Manual\DETAILS\CAD\SANITARY SEWER.dwg May 04, 2021 - 3:24pm

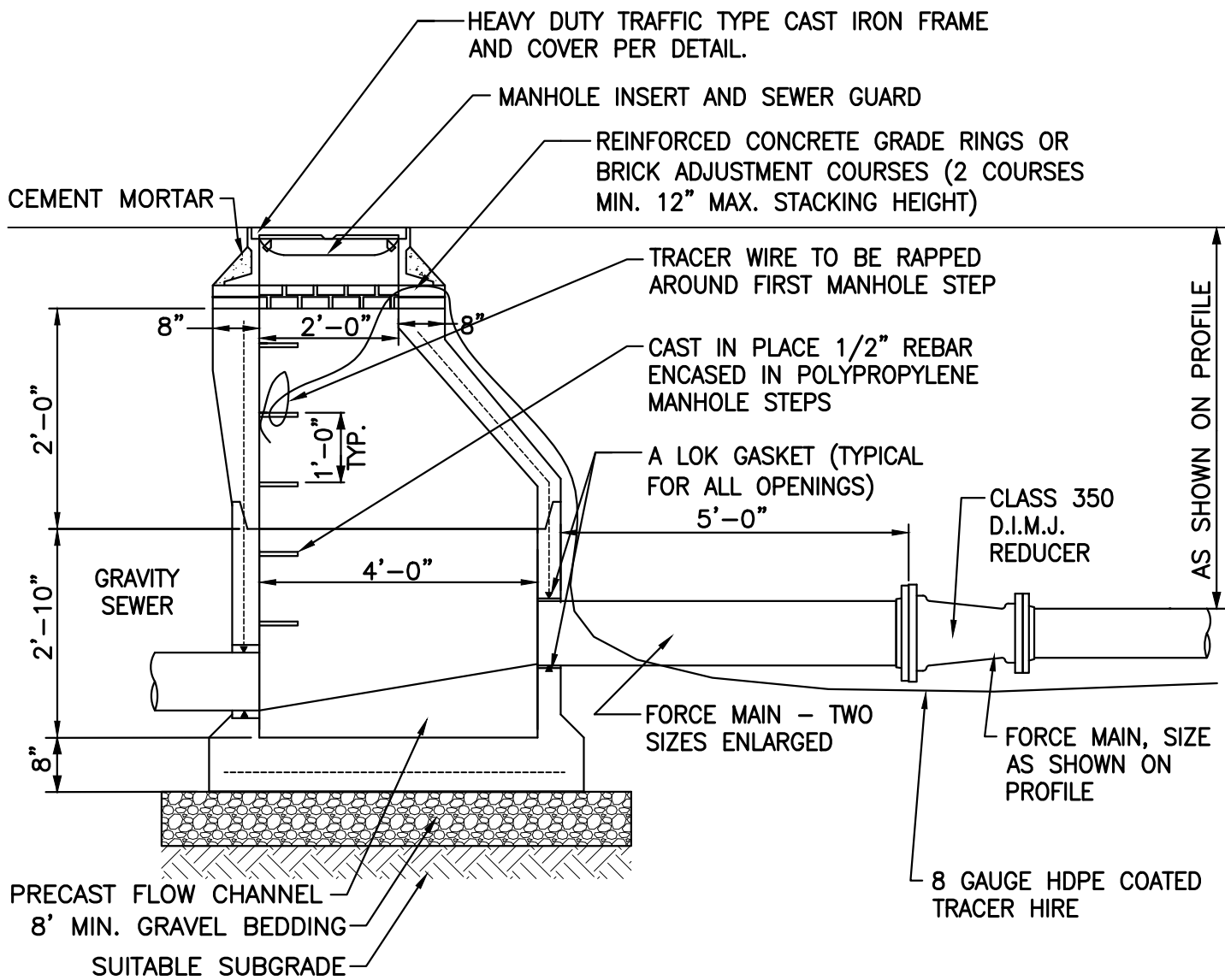

**SECTION**

**NOTES:**

1. MANHOLE SHALL CONFORM TO ASTM C-478, LATEST EDITION.
2. STRUCTURE SHALL BE PRECAST CONCRETE. REFER TO CONSTRUCTION DETAILS, AS APPLICABLE PER PRECAST CONCRETE MANHOLE DETAIL.
3. REFER TO APPROVED CONSTRUCTION PLANS FOR AIR RELEASE VALVE, PIPE AND OTHER SPECIFICATIONS.
4. PROVIDE WARNING TAPE 12" MINIMUM BELOW GRADE ABOVE FORCE MAIN.
5. PROVIDE 8 GAUGE HDPE COATED COPPER TRACER WIRE BELOW FORCE MAIN.

TOWN OF  
 DENTON  
 DEPARTMENT  
 OF  
 PUBLIC WORKS

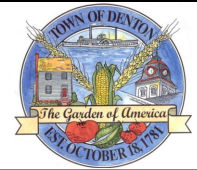

SANITARY SEWER DETAILS  
 FORCE MAIN  
 DISCHARGE MANHOLE

REVISED	SHEET
DEC 2007	
APR 2021	

SS-7.10



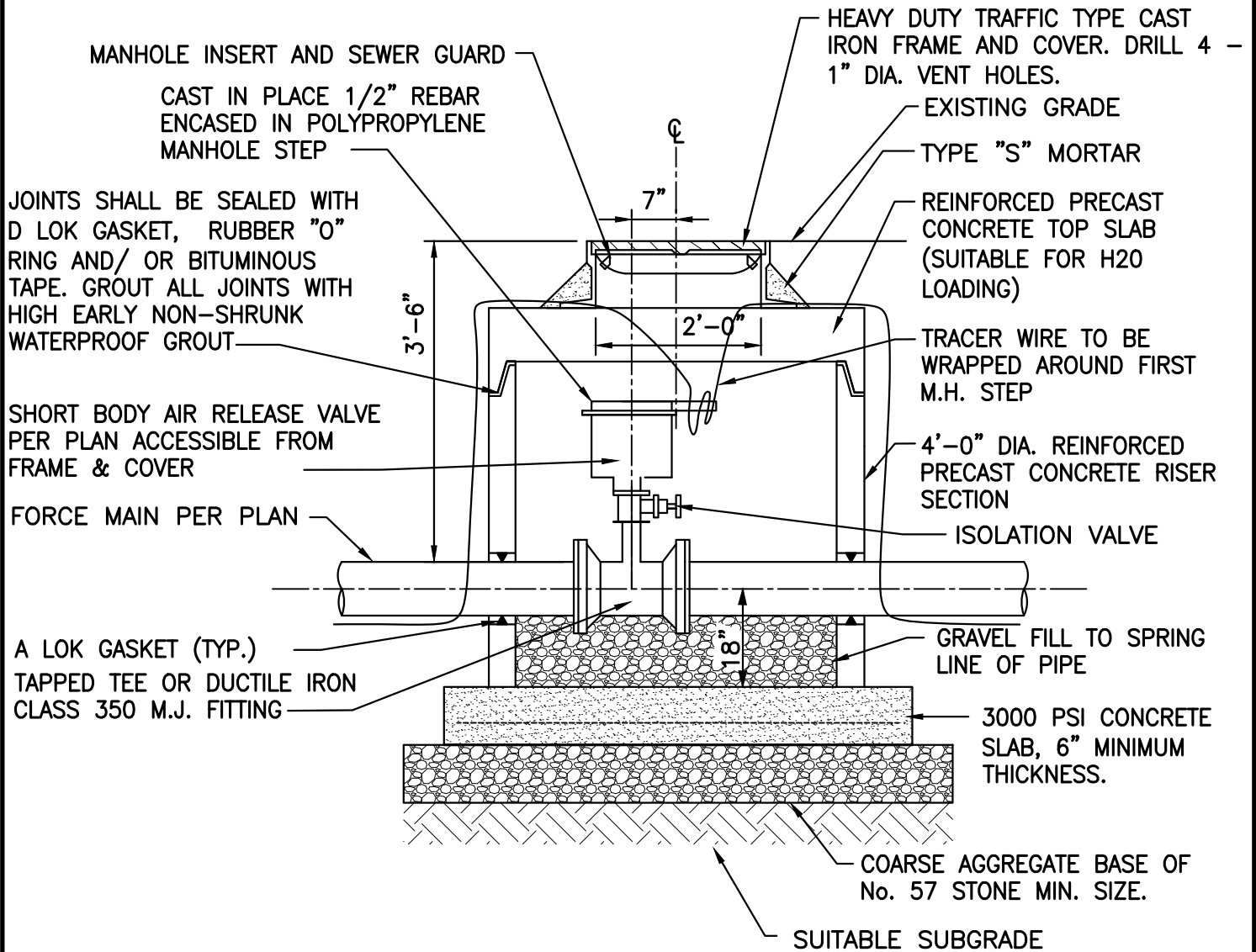

C:\Projects\2020\200110 Town of Denton On-Call Services 2020-2025\Standards & Specs\Revised 2021 (CHB)\Manual\DETAILS\CAD\SANITARY SEWER.dwg May 04, 2021 - 3:24pm



**NOTES:**

1. STRUCTURE SHALL BE PRECAST CONCRETE. REFER TO CONSTRUCTION DETAILS, AS APPLICABLE PER PRECAST CONCRETE MANHOLE DETAIL.
2. REFER TO APPROVED CONSTRUCTION PLANS FOR AIR RELEASE VALVE, PIPE AND OTHER SPECIFICATIONS.
3. PROVIDE WARNING TAPE 12" MINIMUM BELOW GRADE ABOVE FORCE MAIN.
4. PROVIDE 8 GAUGE HDPE COATED COPPER TRACER WIRE BELOW FORCE MAIN.

TOWN OF DENTON DEPARTMENT OF PUBLIC WORKS	 	SANITARY SEWER DETAILS  AIR RELEASE VALVE	REVISED	SHEET  SS-7.20
			DEC 2007	
			APR 2021	

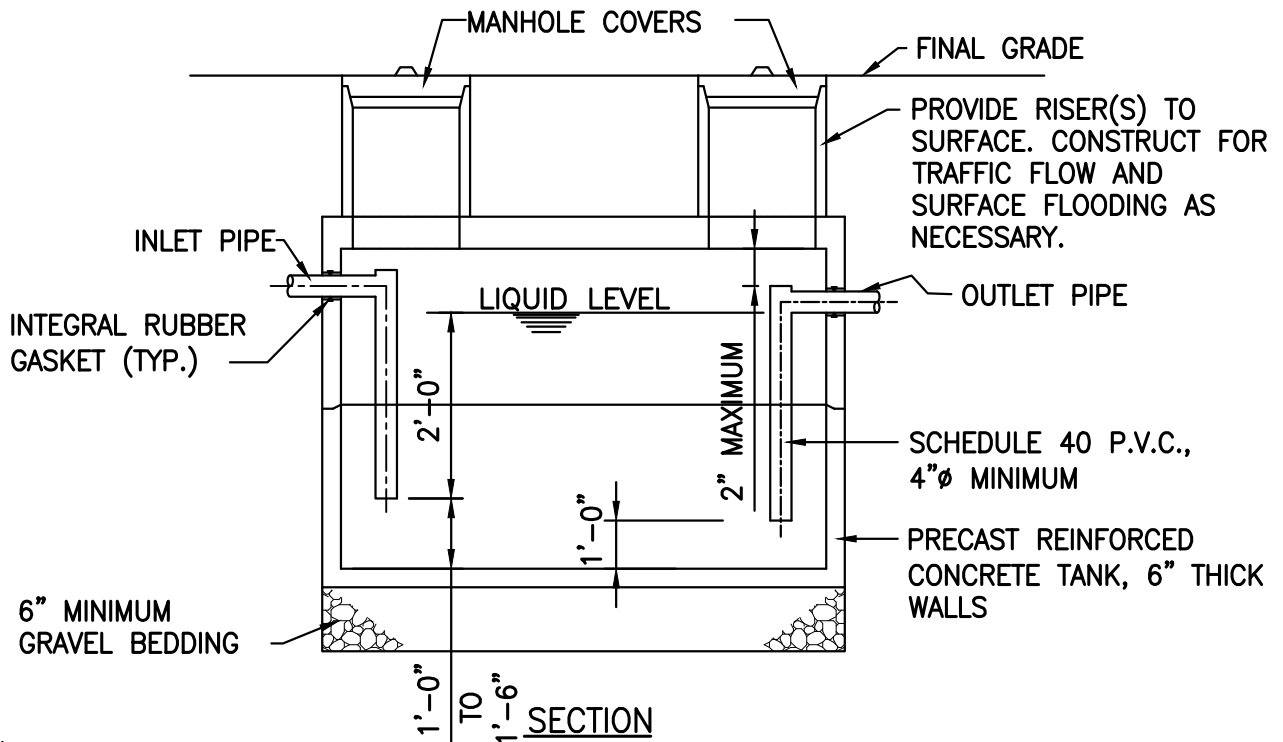
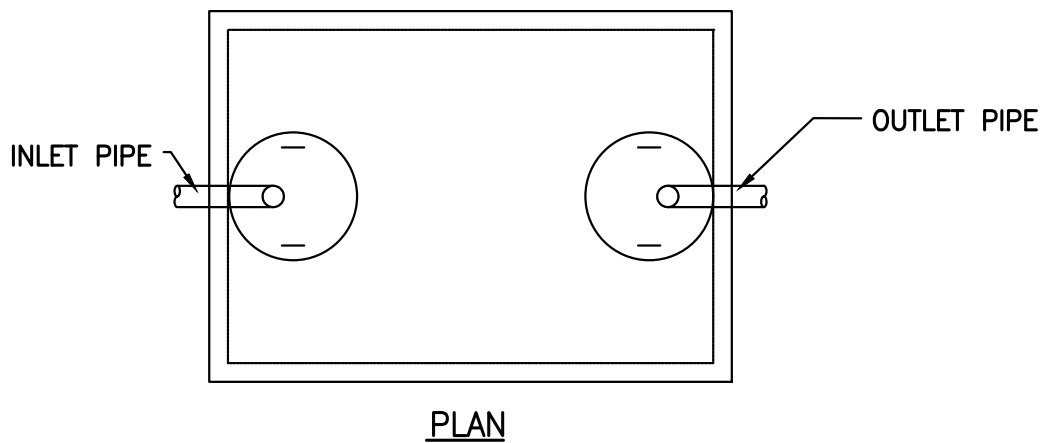

**NOTES:**

1. GREASE TRAP SHALL BE SIZED SUCH THAT GREASE RETENTION CAPACITY IS EQUAL TO AT LEAST TWICE THE PEAK FLOW CAPACITY IN GPM.
2. SEAL ALL SEAMS WITH TYPE "S" NON-SHRINK GROUT.
3. TRAP SHALL HAVE INTEGRAL RUBBER GASKETS FOR INLET AND OUTLET CONNECTIONS.
4. TANK SHALL HAVE TOP SEAM.
5. WHENEVER PRACTICAL ALL OPENINGS MUST BE ABOVE THE SEASONAL HIGH WATER TABLE.

TOWN OF  
DENTON  
DEPARTMENT  
OF  
PUBLIC WORKS

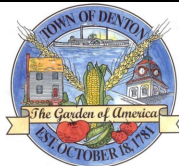

SANITARY SEWER DETAILS  
GREASE TRAP

REVISED  
DEC 2007

SHEET  
SS-8.00

G:\Projects\2020\200110 Town of Denton On-Call Services 2020-2025 Standards & Specs Revised 2021 (CMB)\Manual\DETAILS\CAD\WATER\dwg May 04, 2021 - 3:24pm

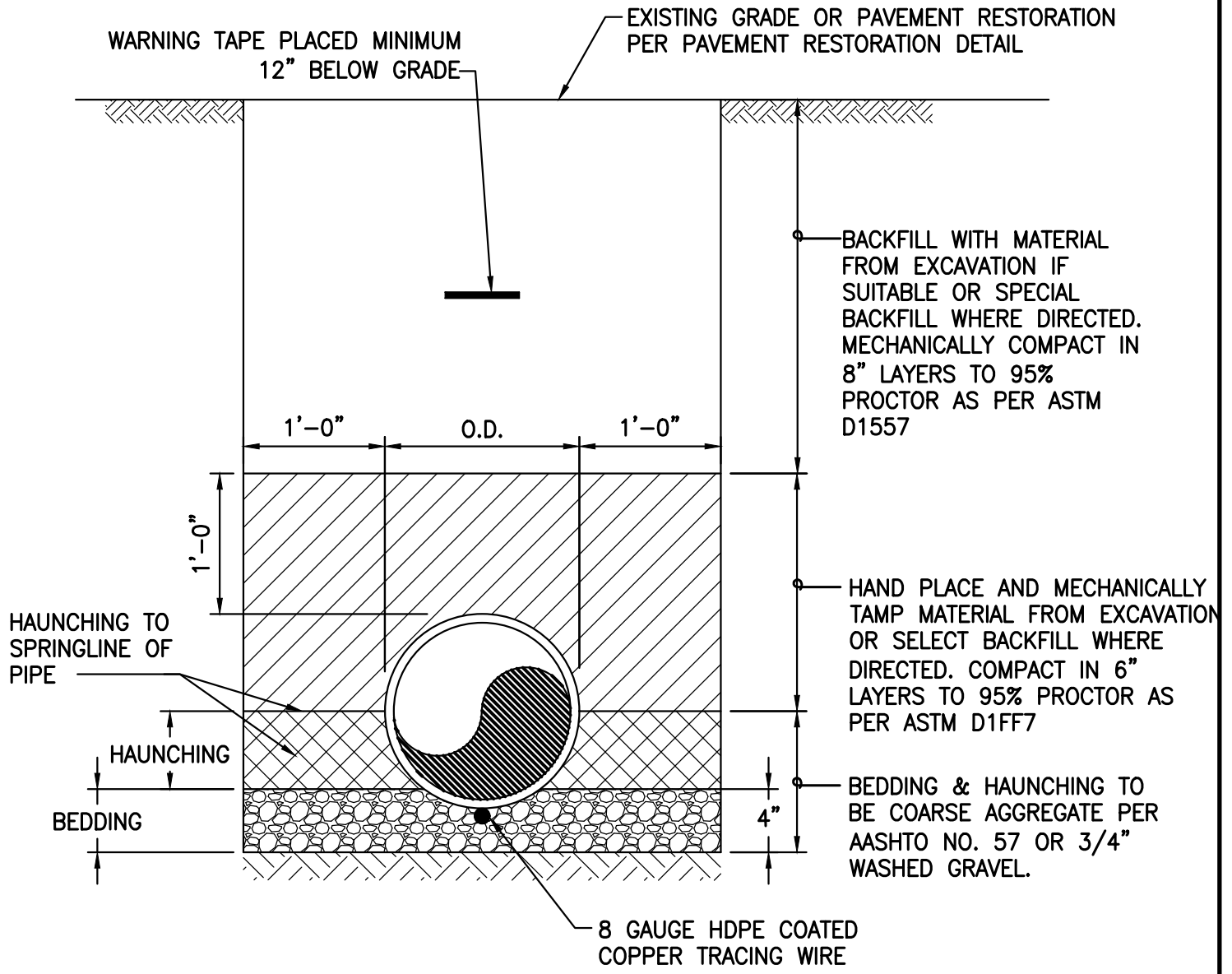

**PIPE BEDDING AND BACKFILL DETAIL**

**NOTES:**

1. WARNING TAPE SHALL BE PLACED 12" MINIMUM BELOW GRADE ABOVE ALL PIPE.
2. THE HDPE COATED COPPER TRACING WIRE SHALL BE A CONTINUOUS CONDUCTOR. CONNECT TO ALL FITTINGS, FIRE HYDRANTS AND SERVICES.
3. ALL FITTINGS SHALL BE AS SPECIFIED IN AWWA C110-93, MECHANICAL JOINT, DUCTILE IRON, PRESSURE RATED AT 350 PSI.
4. ALL FITTINGS SHALL BE RESTRAINED BY THRUST BLOCKS ACCORDING TO STANDARD DETAILS.
5. FIRM BEARING SHALL BE PROVIDED FOR FULL LENGTH OF BARREL. EXCAVATE FOR BELL HOLES.

TOWN OF  
DENTON  
DEPARTMENT  
OF  
PUBLIC WORKS

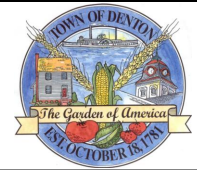

WATER MAIN DETAILS  
PVC WATER MAIN INSTALLATION  
AND COVER

REVISED
DEC 2007
APR 2021

SHEET  
  
W-1.00



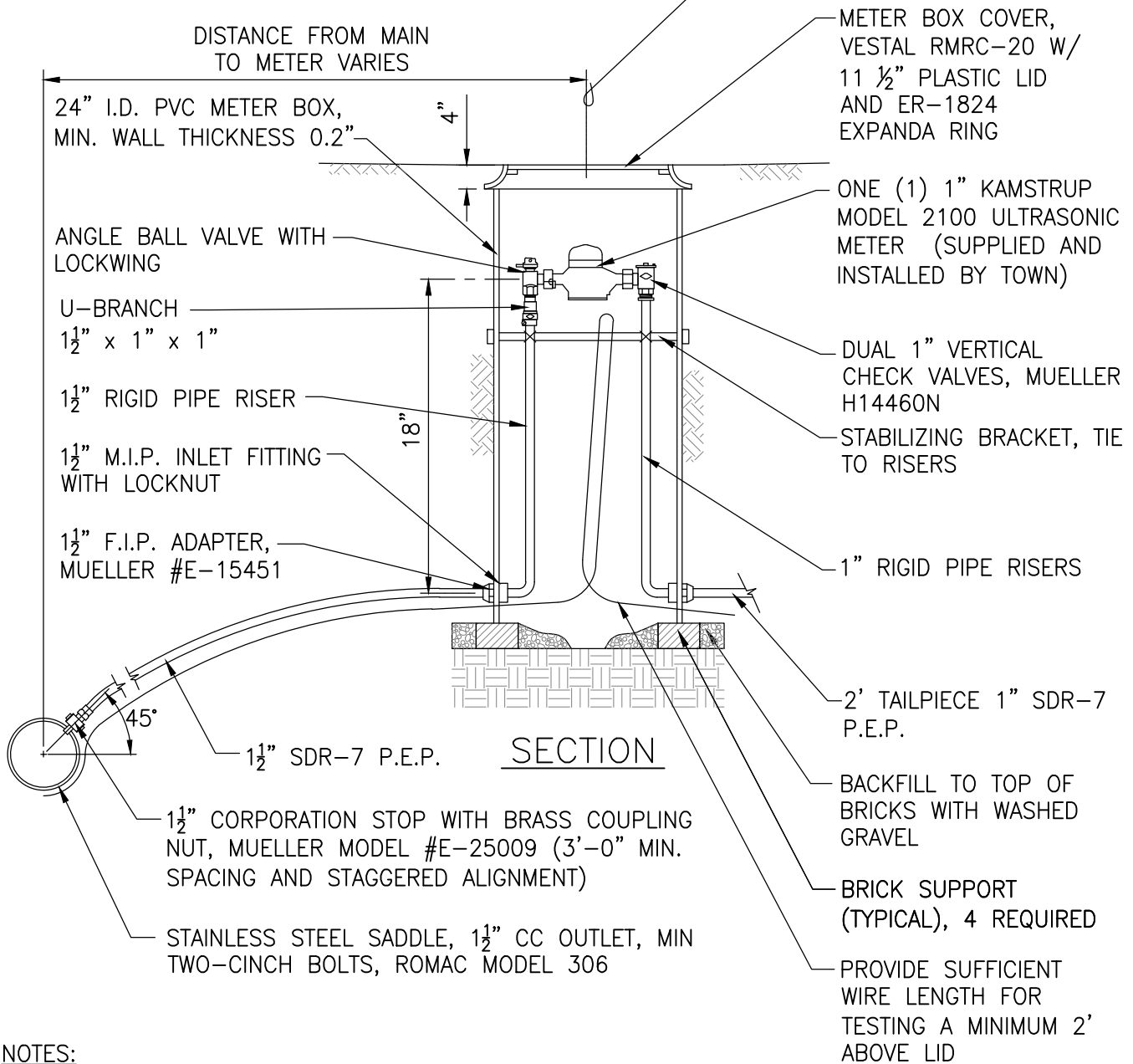
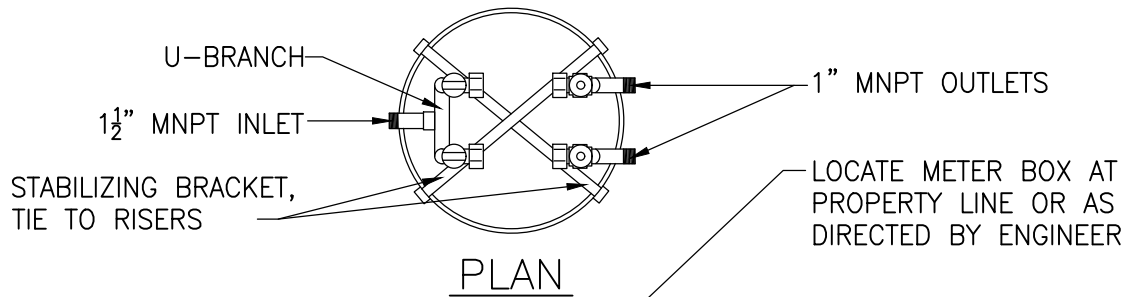

**NOTES:**

1. USE S.S. LINERS IN TUBING AT COMPRESSION CONNECTIONS (MUELLER MODEL #529116, 505142).
2. PIT SETTER SHALL BE EQUAL TO MUELLER 330RD2430FDBS000454N.
3. PROVIDE WARNING TAPE AND 8 GAUGE UNCOATED COPPER TRACER WIRE
4. MAINTAIN 36" MIN. COVER ON WATER SERVICE LINE FROM MAIN TO BUILDING.

TOWN OF DENTON  
DEPARTMENT OF PUBLIC WORKS

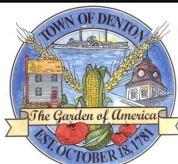

WATER MAIN DETAILS  
DUAL WATER METER

REVISED  
DEC 2007  
APR 2023

SHEET  
W-3.00

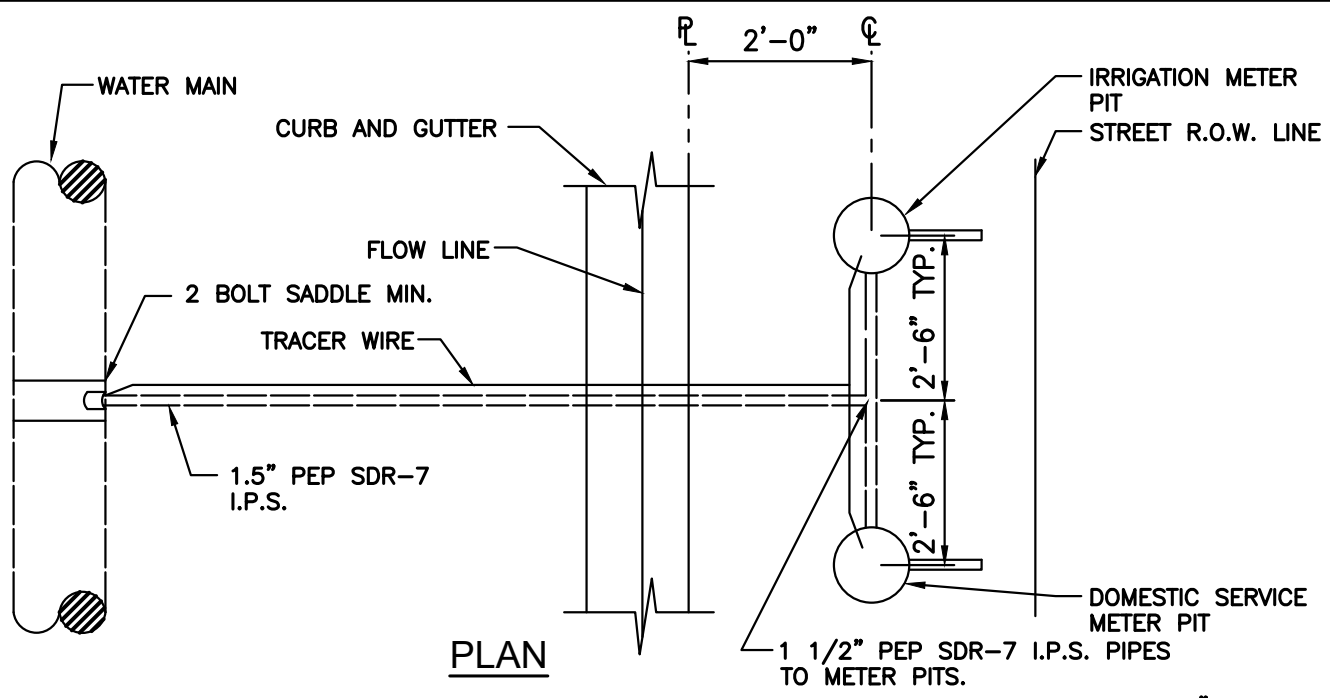

**PLAN**

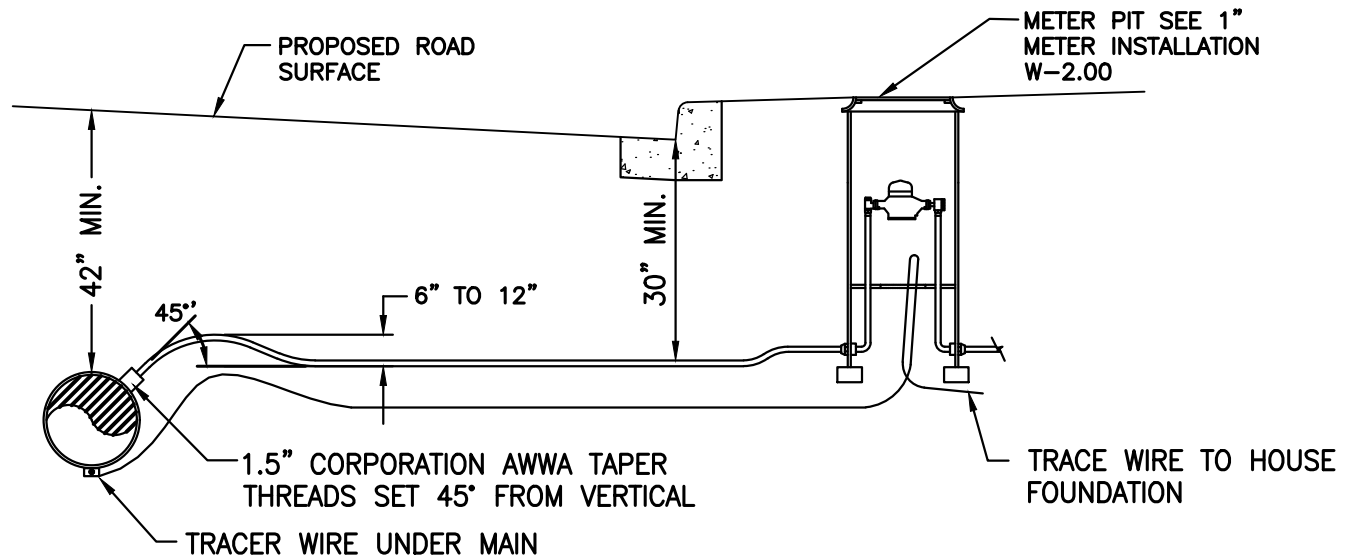

**PROFILE**

**NOTES:**

1. COPPER TRACER WIRE TO BE LAID LEVEL WITH BOTTOM OF MAIN UNLESS OTHERWISE DIRECTED BY ENGINEER.
2. CORPORATION COCK TO BE LEFT OPEN. METER ANGLE VALVE LEFT CLOSED.
3. ADD DETECTOR TAPE AND TRACER WIRE TO ALL PIPE.
4. PE4710 POLYETHYLENE SDR-7 PIPE SHALL BE MANUFACTURED BY JM EAGLE, LOS ANGELES, CA, OR APPROVED EQUAL.
5. BACKFILL AND TAMP WITH SELECT MATERIAL TO PAD PIPE. SEE DETAIL.
6. CERTIFIED FIRE SUPPRESSION SYSTEM DESIGNER SHALL VERIFY LINE SIZE REQUIREMENTS TO STRUCTURE.

G:\Projects\2020\200110 Town of Denton On-Call Services 2020-2025 Standards & Specs Revised 2021 (CHB)\Manual\DETAILS\CAD\WATER.dwg May 27, 2021 - 10:02am

TOWN OF DENTON  
DEPARTMENT OF PUBLIC WORKS

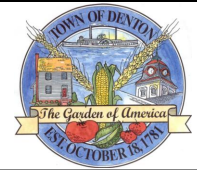

WATER MAIN DETAILS  
DOUBLE METER SERVICE  
INSTALLATION  
(IRRIGATION / DOMESTIC)

REVISED	SHEET W-3.10
DEC 2007	
NOV 2009	
APR 2021	



METER BOX COVER, VESTAL EXPANDA RING  
 P/N 32-048 WITH 20" MONITOR FRAME,  
 VESTAL P/N 32-056 WITH TRUMBALL MODEL  
 367-5610 SOLID PVC LID (20" LID OPENING)

30" ID X 30" PVC METER PIT, BINGHAM  
 AND TAYLOR MODEL PMP 30 SUPPORTED  
 WITH (4) - 4"x8"x6" SOLID CONCRETE  
 BLOCKS EQUALLY SPACED

1 1/2" ANGLE BALL VALVE  
 (FLANGED X FIP)

PROVIDE SUFFICIENT WIRE LENGTH  
 FOR TESTING A MINIMUM 2'  
 ABOVE LID

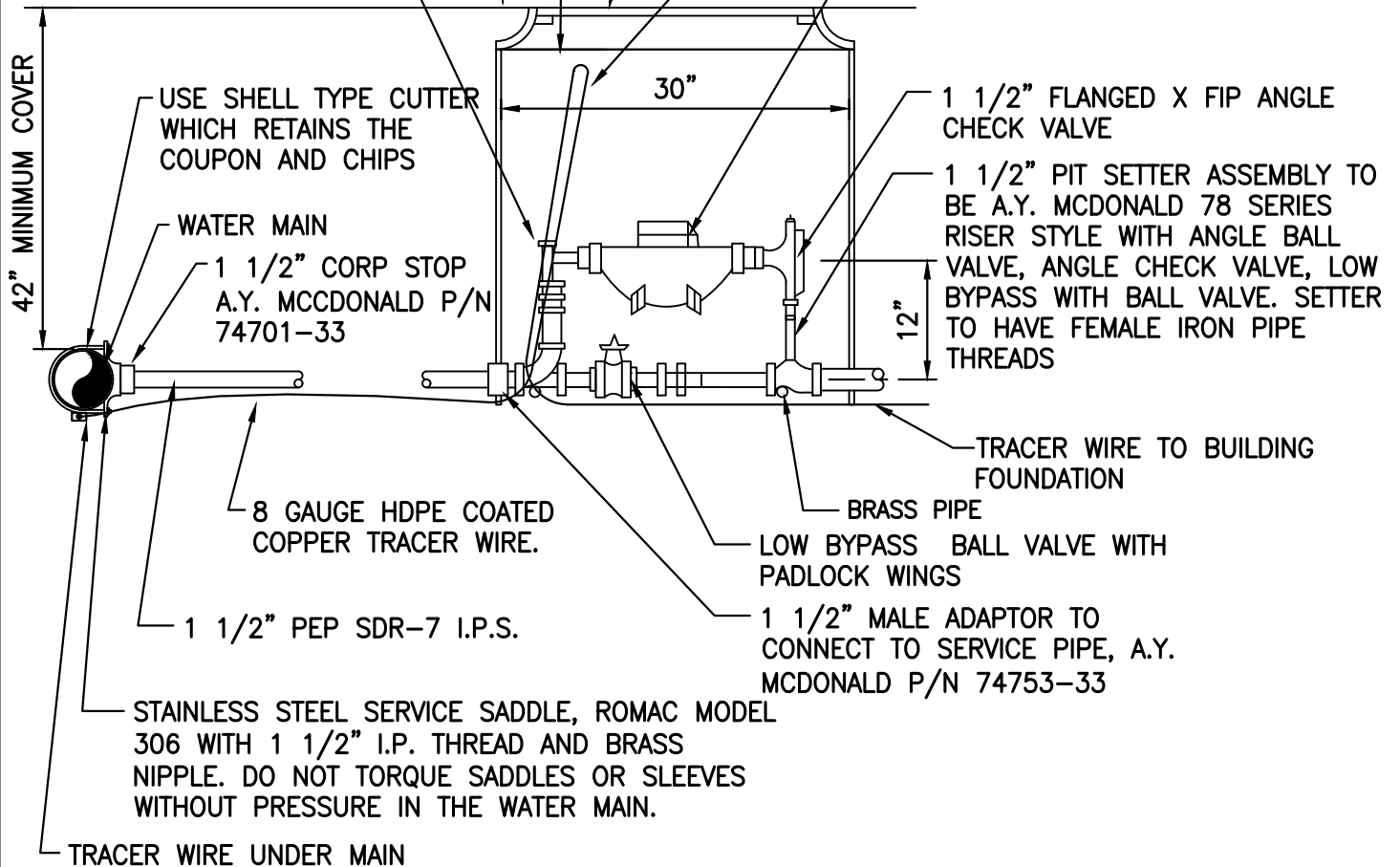

ONE (1) 1 1/2" KAMSTRUP  
 MODEL 3101 ULTRASONIC METER  
 (SUPPLIED BY OWNER, INSTALLED  
 BY CONTRACTOR)



**NOTES:**

1. WRAP ALL THREAD WITH TEFLON TAPE.
2. MAINTAIN 36" COVER ON WATER SERVICE FROM MAIN TO BUILDING.
3. ADD WARNING TAPE 12" MINIMUM BELOW GRADE ABOVE WATER SERVICE.
4. PE4710 POLYETHYLENE SDR-7 PIPE BY JM EAGLE, LOS ANGELES, CA OR APPROVED EQUAL.

G:\Projects\2020\200110 Town of Denton On-Call Services 2020-2025\Standards & Specs\Revised 2021 (CHB)\Manual\DETAILS\CAD\WATER.dwg May 04, 2021 - 3:24pm

TOWN OF DENTON DEPARTMENT OF PUBLIC WORKS	 	WATER MAIN DETAILS COMMERCIAL WATER METER AND 1 1/2" SERVICE CONNECTION	REVISED	SHEET
			DEC 2007	
			APR 2021	
			W-4.00	

METER BOX COVER, VESTAL EXPANDA RING  
 P/N 32-043 WITH 20" MONITOR FRAME,  
 VESTAL P/N 32-056 WITH TRUMBALL MODEL  
 367-5610 SOLID PVC LID (20" LID OPENING)

36" ID X 30" PVC METER PIT, BINGHAM  
 AND TAYLOR MODEL PMP 36 SUPPORTED  
 WITH (4) - 4"x8"x6" SOLID CONCRETE  
 BLOCKS EQUALLY SPACED

PROVIDE SUFFICIENT WIRE LENGTH  
 FOR TESTING A MINIMUM 2'  
 ABOVE LID

ONE (1) 2" KAMSTRUP MODEL  
 3101 ULTRASONIC METER  
 (SUPPLIED BY OWNER, INSTALLED  
 BY CONTRACTOR)

FINISH GRADE

2" ANGLE BALL VALVE  
 (FLANGED X FIP)

42" MINIMUM COVER

USE SHELL TYPE CUTTER  
 WHICH RETAINS THE  
 COUPON AND CHIPS

WATER MAIN

2" CORP STOP A.Y.  
 MCDONALD P/N  
 74701-33

36"

2" FLANGED X FIP ANGLE CHECK  
 VALVE

2" PIT SETTER ASSEMBLY TO BE  
 A.Y. MCDONALD 78 SERIES RISER  
 STYLE WITH ANGLE BALL VALVE,  
 ANGLE CHECK VALVE, LOW BYPASS  
 WITH BALL VALVE. SETTER TO  
 HAVE FEMALE IRON PIPE THREADS

12"

TRACER WIRE TO BUILDING  
 FOUNDATION

8 GAUGE HDPE COATED  
 COPPER TRACER WIRE

BRASS PIPE

LOW BYPASS BALL VALVE WITH  
 PADLOCK WINGS

2" PEP SDR-7 I.P.S.

2" MALE ADAPTOR TO CONNECT  
 TO SERVICE PIPE, A.Y. MCDONALD  
 P/N 74753-33

STAINLESS STEEL SERVICE SADDLE, ROMAC MODEL  
 306 WITH 2" I.P. THREAD AND BRASS NIPPLE. DO  
 NOT TORQUE SADDLES OR SLEEVES WITHOUT  
 PRESSURE IN THE WATER MAIN.

TRACER WIRE UNDER MAIN

**NOTES:**

1. WRAP ALL THREAD WITH TEFLON TAPE.
2. MAINTAIN 36" COVER ON WATER SERVICE FROM MAIN TO BUILDING.
3. ADD WARNING TAPE 12" MINIMUM BELOW GRADE ABOVE WATER SERVICE.
4. PE4710 POLYETHYLENE SDR-7 PIPE BY JM EAGLE, LOS ANGELES, CA OR APPROVED EQUAL.

G:\Projects\2020\200110 Town of Denton On-Call Services 2020-2025\Standards & Specs\Revised 2021 (CHB)\Manual\DETAILS\CAD\WATER\wg May 04, 2021 - 3:24pm

TOWN OF DENTON DEPARTMENT OF PUBLIC WORKS	 	WATER MAIN DETAILS COMMERCIAL WATER METER AND 2" SERVICE CONNECTION	REVISED	SHEET
			DEC 2007	
			APR 2021	
			W-4.10	



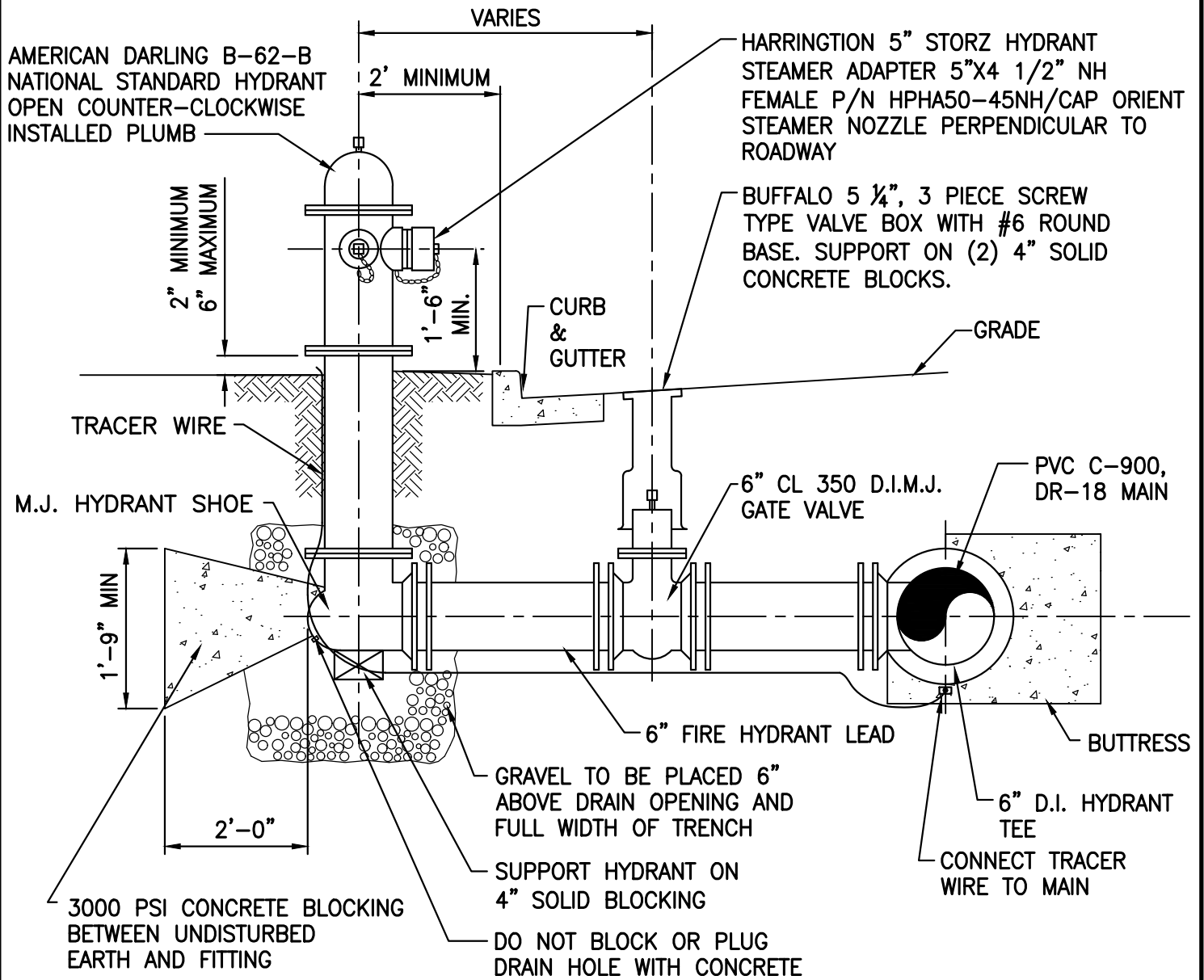

C:\Projects\2020\200110 Town of Denton On-Call Services 2020-2025\Standards & Specs\Revised 2021 (CHB)\Manual\DETAILS\CAD\WATER.dwg May 27, 2021 - 10:02am



**NOTES:**

1. RETAINER GLANDS SHALL BE UTILIZED AT ALL JOINTS.
2. ALL VALVES, FITTINGS TO BE CLASS 350 D.I.M.J.
3. FIRE HYDRANT TO BE INSTALLED AT THE PROPERTY LINE BETWEEN LOTS.
4. HYDRANT TO BE PAINTED SAFETY YELLOW.
5. PROVIDE WARNING TAPE 12" MINIMUM BELOW GRADE ABOVE HYDRANT LEAD.
6. PROVIDE 8 GAUGE HDPE COATED COPPER TRACER WIRE.

TOWN OF DENTON DEPARTMENT OF PUBLIC WORKS	 	WATER MAIN DETAILS TYPICAL FIRE HYDRANT INSTALLATION	REVISED	SHEET  W-5.00
			DEC 2007	
			APR 2021	

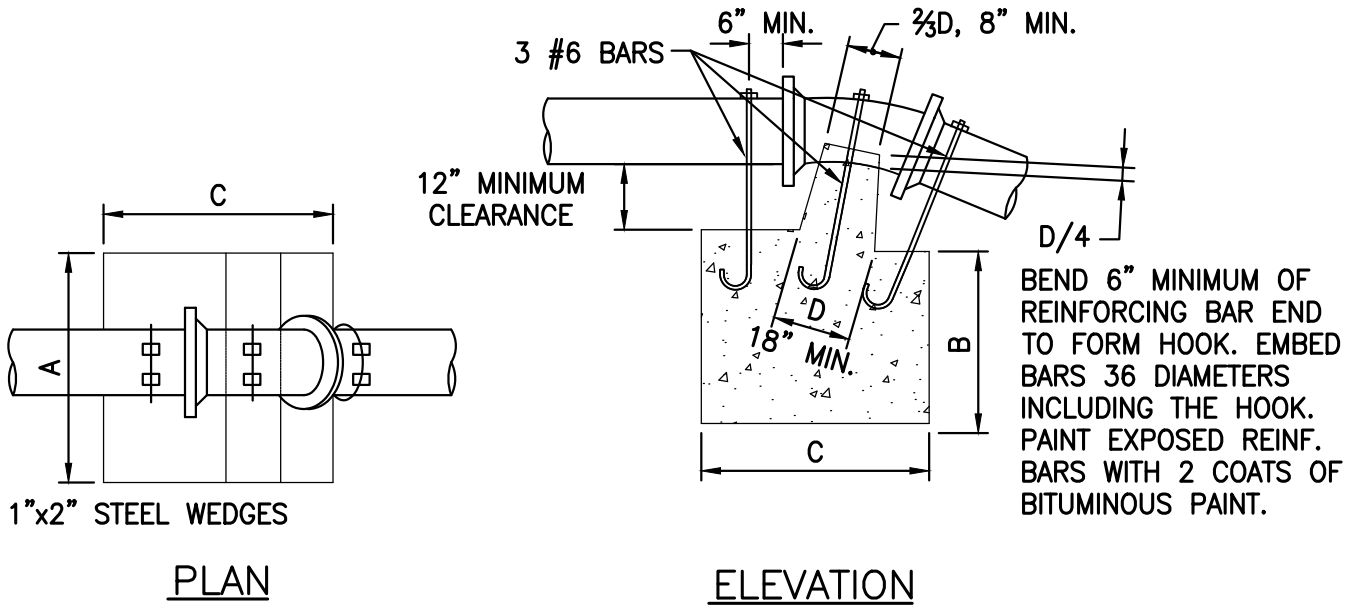

G:\Projects\2020\200110 Town of Denton On-Call Services 2020-2025 Standards & Specs\Revised 2021 (CMB)\Manual\DETAILS\CAD\WATER\wg May 04, 2021 - 3:24pm



		BUTTRESS DIMENSIONS					
BEND		3"	4"	6"	8"	10"	12"
ANCHORAGE 11 ¼° BEND	A	1'-6"	1'-6"	1'-6"	1'-6"	1'-5"	3'-0"
	B	1'-3"	1'-3"	1'-3"	1'-9"	1'-3"	2'-0"
	C	2'-0"	2'-0"	2'-0"	2'-6"	2'-9"	3'-0"
ANCHORAGE 22 ½° BEND	A	2'-0"	2'-0"	2'-0"	3'-4"	3'-8"	4'-0"
	B	1'-9"	1'-9"	1'-9"	2'-3"	2'-6"	2'-6"
	C	2'-6"	2'-6"	2'-6"	2'-8"	3'-10"	4'-0"
ANCHORAGE 45° BEND	A	2'-6"	2'-6"	2'-6"	3'-0"	4'-0"	4'-6"
	B	2'-6"	2'-6"	2'-6"	2'-9"	3'-0"	3'-6"
	C	3'-0"	3'-0"	3'-0"	4'-0"	4'-6"	4'-9"

**NOTES:**

1. ALL CONCRETE TO HAVE MINIMUM COMPRESSIVE STRENGTH OF 3,000 PSI.
2. BUTTRESS DIMENSIONS GIVEN ARE MINIMUM DIMENSIONS BASED UPON 3000 PSI SOIL BEARING CAPACITY AND 150 PSI INTERNAL PIPE PRESSURE.
3. ALL CONCRETE SHALL BE CARRIED TO UNDISTURBED EARTH.
4. PIPE JOINTS WITH KRAFT PAPER OR 4 MIL POLYETHYLENE PRIOR TO POURING OF CONCRETE.

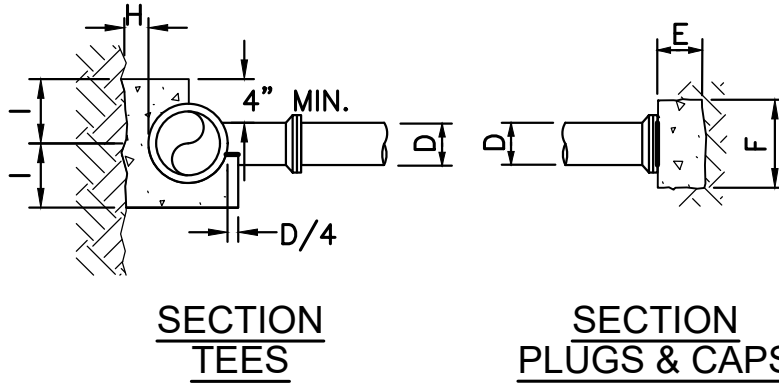
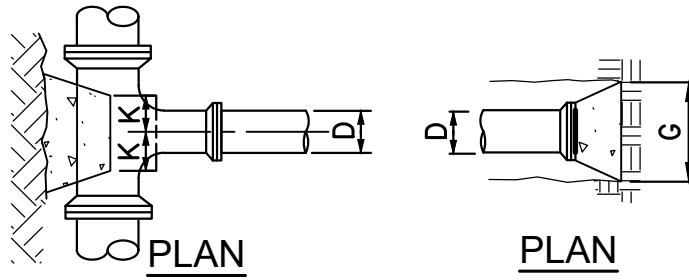

TOWN OF DENTON DEPARTMENT OF PUBLIC WORKS	 	WATER MAIN DETAILS BUTTRESS FOR UPPER VERTICAL BENDS	REVISED	SHEET W-6.00
			DEC 2007	



		BUTTRESS DIMENSIONS				
D		4"	6"	8"	10"	12"
PLUGS & CAPS	E	0'-6"	0'-6"	0'-8"	0'-8"	0'-10"
	F	1'-0"	1'-0"	1'-4"	1'-8"	2'-0"
	G	1'-5"	1'-5"	1'-11"	2'-5"	2'-10"
TEES	H	0'-8"	0'-8"	0'-9"	0'-10"	1'-0"
	I	0'-8"	0'-8"	0'-10"	1'-0"	1'-3"
	J	0'-7"	0'-7"	0'-9"	1'-0"	1'-2"
	K	0'-6"	0'-6"	0'-8"	0'-8"	0'-8"

**NOTES:**

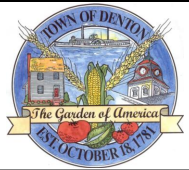
1. ALL CONCRETE TO HAVE MINIMUM COMPRESSIVE STRENGTH OF 3000 PSI.
2. BUTTRESS DIMENSIONS GIVEN ARE MINIMUM DIMENSIONS BASED UPON 3000 PSI SOIL BEARING CAPACITY AND 150 PSI INTERNAL PIPE PRESSURE.
3. ALL CONCRETE SHALL BE CARRIED TO UNDISTURBED EARTH.
4. WRAP PIPE JOINTS WITH KRAFT PAPER OR 4 MIL POLYETHYLENE SHEETING PRIOR TO POURING OF CONCRETE.

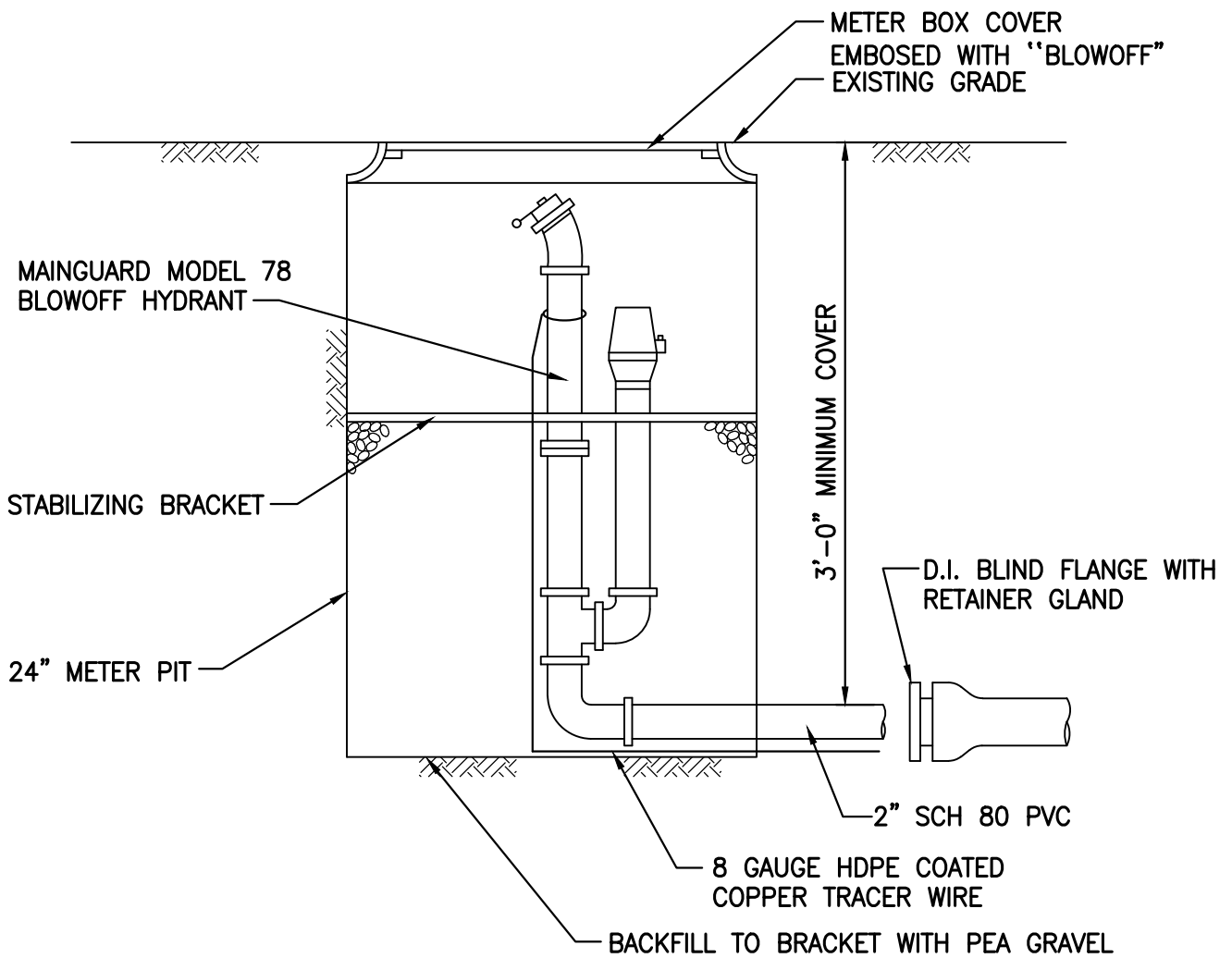

TOWN OF DENTON DEPARTMENT OF PUBLIC WORKS	 	WATER MAIN DETAILS BUTTRESS FOR TEES, PLUGS & CAPS	REVISED	SHEET
			DEC 2007	
			W-6.10	



**NOTES:**

1. INSTALL WARNING TAPE.
2. LOCATE BLOWOFF ASSEMBLY AS DIRECTED BY ENGINEER.

G:\Projects\2020\200110 Town of Denton On-Call Services 2020-2025\Standards & Specs\Revised 2021 (CHB)\Manual\DETAILS\CAD\WATER.dwg May 04, 2021 - 3:25pm

<b>TOWN OF DENTON DEPARTMENT OF PUBLIC WORKS</b>			<b>WATER MAIN DETAILS</b>	<b>REVISED</b>	<b>SHEET</b>  <b>W-7.00</b>
			<b>2" BLOWOFF ASSEMBLY</b>	<b>DEC 2007</b>	
				<b>APR 2021</b>	

C:\Projects\2020\200110 Town of Denton On-Call Services 2020-2025 Standards & Specs\Revised 2021 (CHB)\Manual\DETAILS\CAD\STORM WATER.dwg May 04, 2021 - 3:25pm

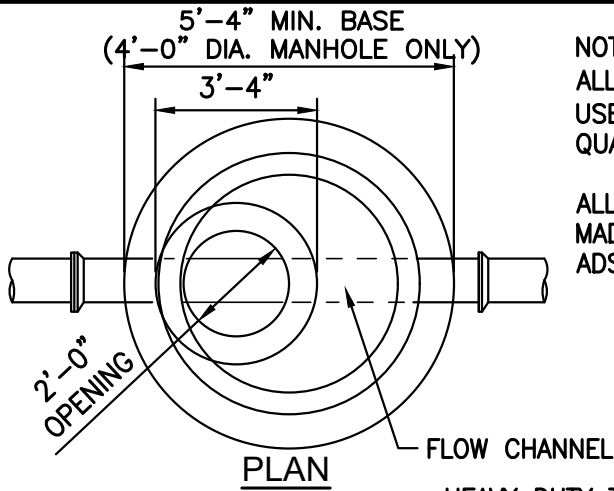

**NOTE:**  
ALL BRICK WORK FOR GRADE/LEVEL ADJUSTMENT SHALL USE TYPE "S" MORTAR AND BE CONSTRUCTED BY QUALIFIED MECHANICS.

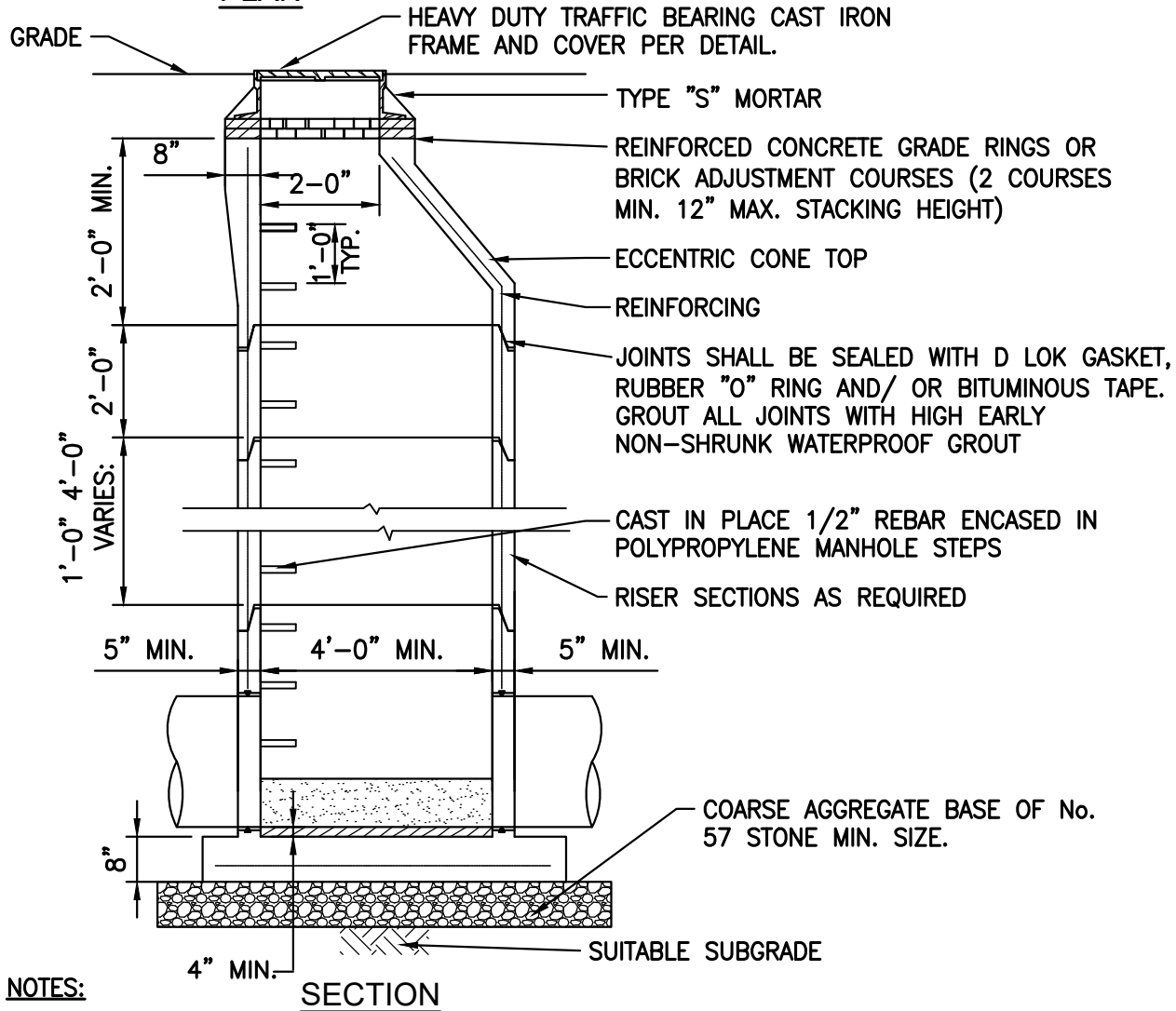

ALL HDPE PIPE CONNECTIONS TO STRUCTURE SHALL BE MADE WITH WATER STOP GASKET AS MANUFACTURED BY ADS OR APPROVED EQUAL



**NOTES:**

**SECTION**

1. MANHOLE SHALL CONFORM TO ASTM C-478, LATEST EDITION.
2. PARGE ALL JOINTS WITH TYPE "S" NON-SHRINK GROUT.
3. ALL BRICK WORK FOR GRADE/LEVEL ADJUSTMENT SHALL USE TYPE "S" MORTAR AND BE CONSTRUCTED BY QUALIFIED MECHANICS.
4. ALL HDPE PIPE CONNECTIONS TO STRUCTURE SHALL BE MADE WITH WATER STOP GASKET AS MANUFACTURED BY ADS OR APPROVED EQUAL.

<p>TOWN OF DENTON DEPARTMENT OF PUBLIC WORKS</p>  	<p>STORM DRAIN DETAILS PRECAST CONCRETE MANHOLE</p>		<p>REVISED DEC 2007 APR 2021</p>	<p>SHEET SD-1.00</p>

G:\Projects\2020\20110 Town of Denton On-Call Services 2020-2025\Standards & Specs\Revised 2021 (CAD)\Manual\DETAILS\CAD\STORM WATER.dwg May 04, 2021 - 3:25pm

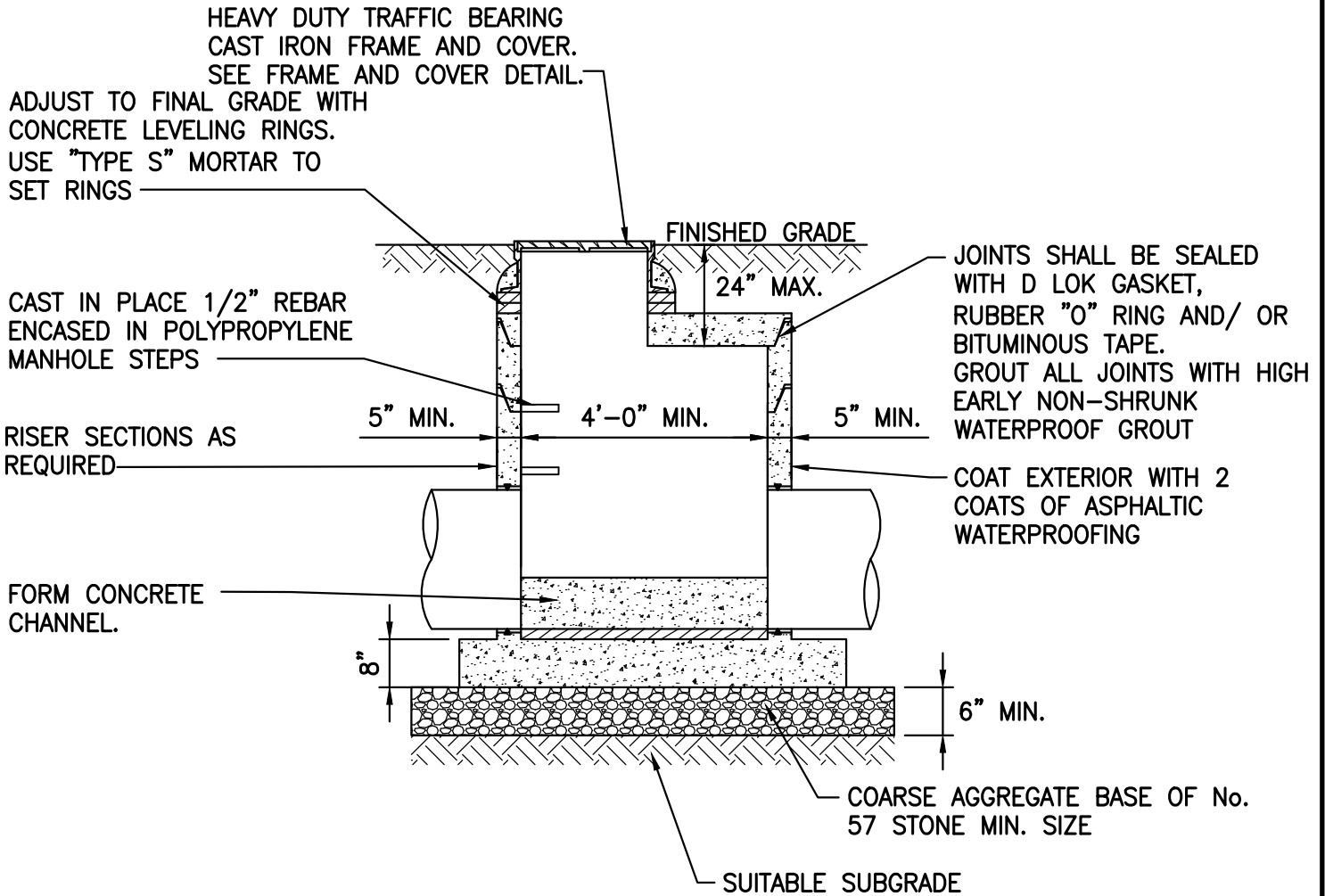

**NOTES:**

1. PRECAST MANHOLE SHALL CONFORM TO ASTM C-478 LATEST EDITION.
2. ALL MORTAR SHALL BE "TYPE S".
3. BENCH AND CHANNEL SHALL BE BRICK OR HAND FORMED CONCRETE. MINIMUM THICKNESS OF 4", BENCH SHALL SLOPE TO TOP OF PIPE 1/2" FALL PER FOOT.
4. ALL BRICK WORK FOR GRADE/LEVEL ADJUSTMENT SHALL BE CONSTRUCTED BY QUALIFIED MECHANICS.
5. ALL HDPE PIPE CONNECTIONS TO STRUCTURE SHALL BE MADE WITH A WATER STOP GASKET AS MANUFACTURED BY ADS, OR APPROVED EQUAL.

<p>TOWN OF DENTON DEPARTMENT OF PUBLIC WORKS</p>			STORM DRAIN DETAILS	REVISED	SHEET
			SHALLOW PRECAST	DEC 2007	
			MANHOLE	APR 2021	
				SD-1.10	

C:\Projects\2020\200110 Town of Denton On-Call Services 2020-2025 Standards & Specs\Revised 2021 (CMR)\Manual\DETAILS\CAD\STORM WATER.dwg May 04, 2021 - 3:25pm

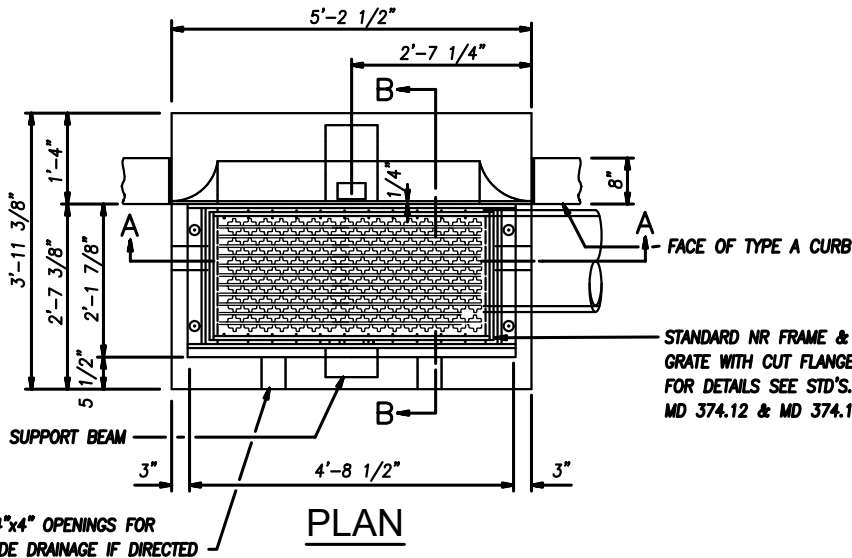

**NOTE:**

1. INLET SHALL BE CONSTRUCTED OF REINFORCED CONCRETE MIX NO. SIZE, TYPE & DIRECTION OF INLET CONNECTION WILL VARY TO SUIT CONDITIONS. SEE S.H.A. SPECIFICATIONS FOR INLETS. REINFORCEMENT REQUIRED ON OUTSIDE, AS WELL AS ON INSIDE, OF WALLS BELOW 7'-0" WHEN "A" IS GREATER THAN 7'-0". SPACING, SAME AS FOR INSIDE OF WALL. PLACE 1/4" EXPANSION MATERIAL OF SAME TYPE APPROVED FOR PAVEMENT BETWEEN THE FRAME & ABUTTING RIGID PAVEMENT, & BETWEEN ENDS OF INLET CURB & NORMAL CURB. BRICK FOR MASONRY TO COMPLY WITH THE S.H.A. SPECIFICATIONS. FOR UNDEPRESSED INLETS, USE NORMAL PAVEMENT SLOPE. IF LADDER RUNGS ARE REQUIRED SEE STD. NO. MD 383.91 OR MD 383.92.
2. ALL BRICK WORK FOR GRADE/LEVEL ADJUSTMENT SHALL USE TYPE "S" MORTAR AND BE CONSTRUCTED BY QUALIFIED MECHANICS.
3. PARGE ALL JOINTS WITH BITUMASTIC TAPE, GROUT SEAMS WITH TYPE "S" NON-SHRINK GROUT.
4. ALL HDPE PIPE CONNECTIONS TO STRUCTURE SHALL BE MADE WITH WATER STOP GASKET AS MANUFACTURED BY ADS OR APPROVED EQUAL.

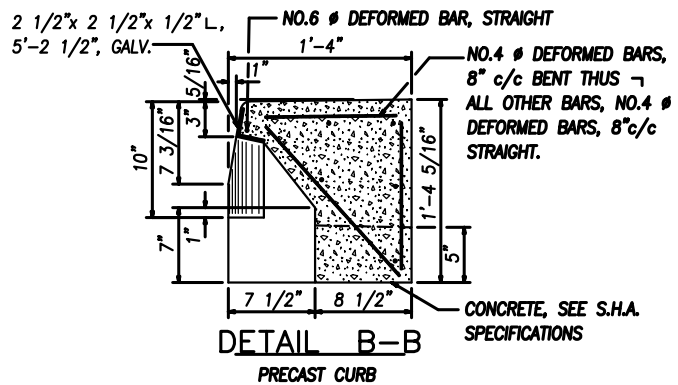
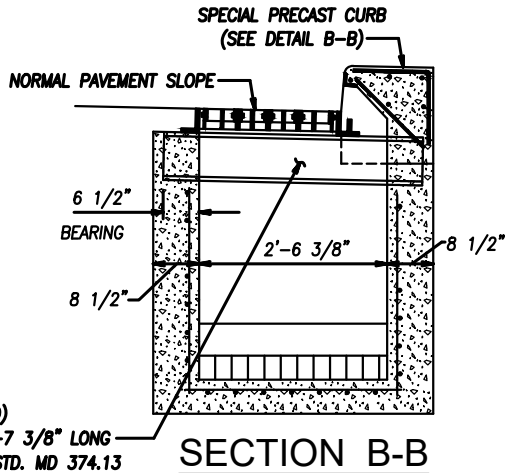
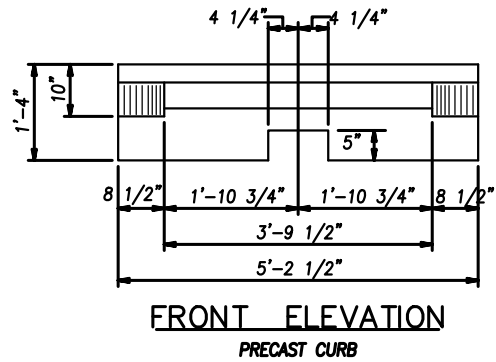
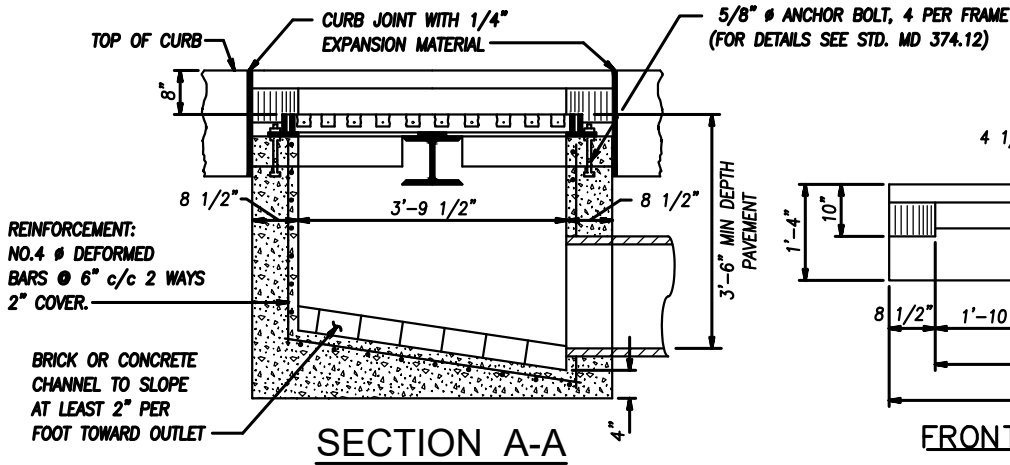

**W8x31 (GALVANIZED)**  
 SUPPORT BEAM 3'-7 3/8" LONG  
 FOR DETAILS SEE STD. MD 374.13  
 FOR METHOD OF ANCHORING  
 SUPPORT BEAM INLET IF  
 CONSTRUCTED OF BRICK  
 SEE STD. MD 374.15  
 (FOR INLET REPAIR ONLY)

TOWN OF  
 DENTON  
 DEPARTMENT  
 OF  
 PUBLIC WORKS



STORM DRAIN DETAILS  
 STANDARD "NR" INLET

REVISED  
 DEC 2007  
 APR 2021

SHEET  
 SD-2.00



C:\Projects\2020\200110 Town of Denton On-Call Services 2020-2025 Standards & Specs (Revised 2021 (CMB)\Manual\DETAILS\CAD\STORM WATER.dwg May 04, 2021 - 3:25pm

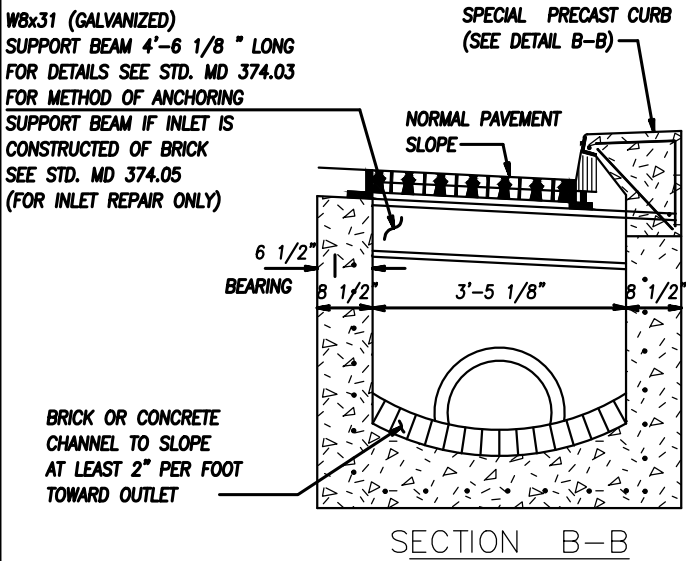
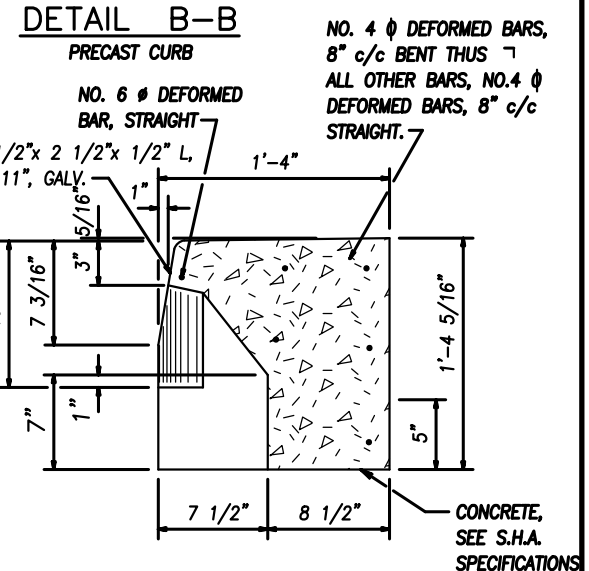
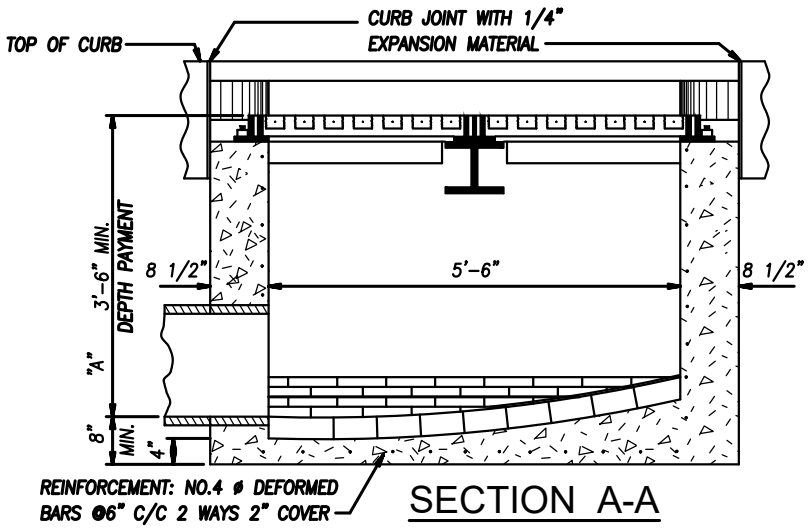
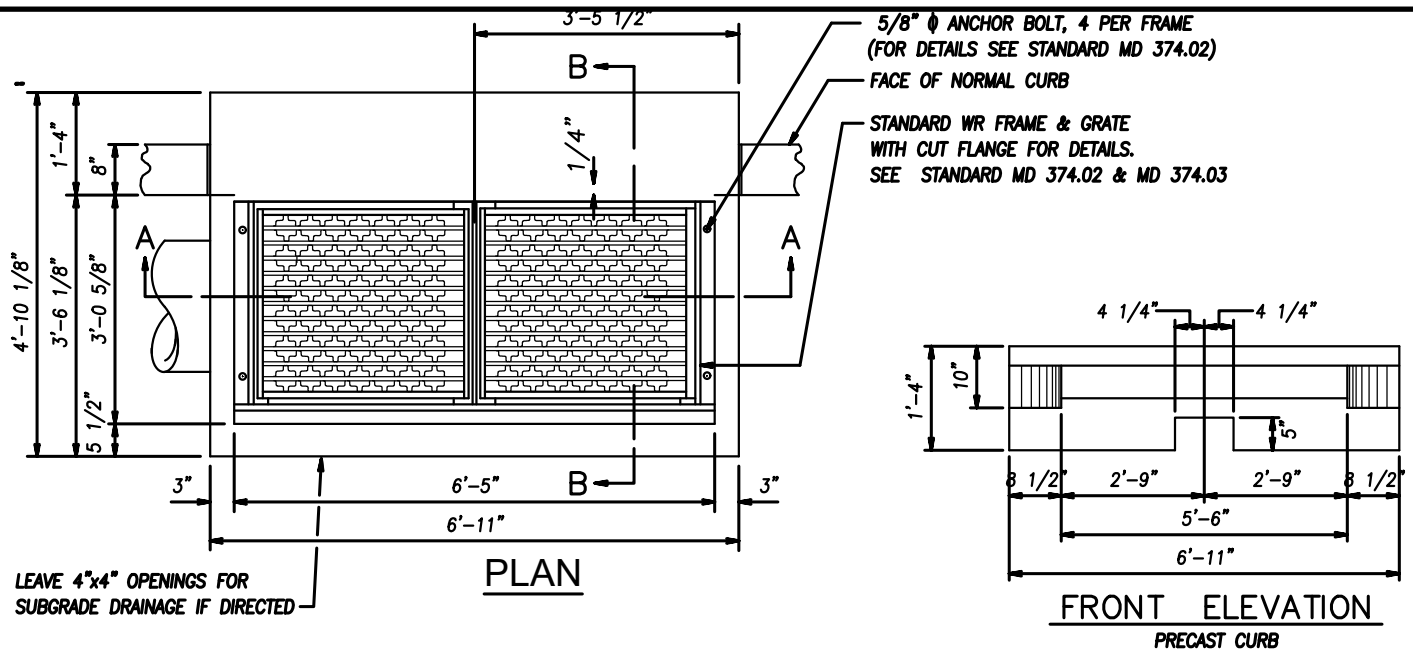

- NOTE:**
1. INLET SHALL BE CONSTRUCTED OF REINFORCED CONCRETE MIX NO. SIZE, TYPE & DIRECTION OF INLET CONNECTION WILL VARY TO SUIT CONDITIONS. SEE S.H.A. SPECIFICATIONS FOR INLETS. REINFORCEMENT REQUIRED ON OUTSIDE, AS WELL AS ON INSIDE, OF WALLS BELOW 7'-0" WHEN "A" IS GREATER THAN 7'-0". SPACING, SAME AS FOR INSIDE OF WALL PLACE 1/4" EXPANSION MATERIAL OF SAME TYPE APPROVED FOR PAVEMENT BETWEEN THE FRAME & ABUTTING RIGID PAVEMENT, & BETWEEN ENDS OF INLET CURB & NORMAL CURB. BRICK FOR MASONRY TO COMPLY WITH THE S.H.A. SPECIFICATIONS. FOR UNDEPRESSED INLETS, USE NORMAL PAVEMENT SLOPE. IF LADDER RUNGS ARE REQUIRED SEE STD. NO. MD 383.91 OR MD 383.92.
  2. ALL BRICK WORK FOR GRADE/LEVEL ADJUSTMENT SHALL USE TYPE "S" MORTAR AND BE CONSTRUCTED BY QUALIFIED MECHANICS.
  3. PARGE ALL JOINTS WITH BITMASTIC TAPE, GROUT SEAMS WITH TYPE "S" NON-SHRINK GROUT.
  4. ALL HDPE PIPE CONNECTIONS TO STRUCTURE SHALL BE MADE WITH WATER STOP GASKET AS MANUFACTURED BY ADS OR APPROVED EQUAL.



TOWN OF DENTON DEPARTMENT OF PUBLIC WORKS	 	STORM DRAIN DETAILS STANDARD "WR" INLET	REVISED	SHEET
			DEC 2007	
			APR 2021	
			SD-2.10	

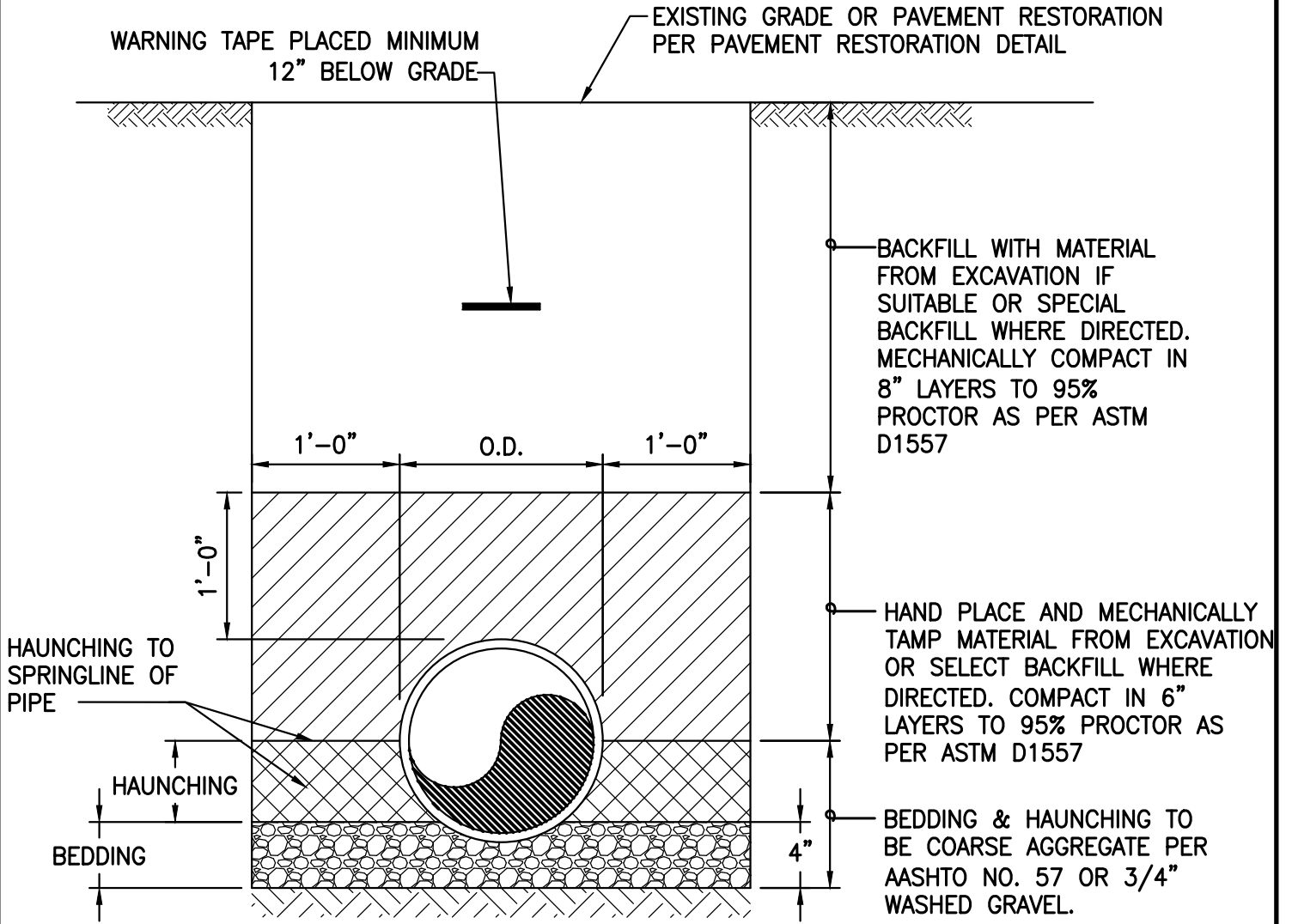

C:\Projects\2020\20110 Town of Denton On-Call Services 2020-2025\Standards & Specs\Revised 2021 (CMB)\Manual\DETAILS\CAD\STORM WATER.dwg May 04, 2021 - 3:25pm

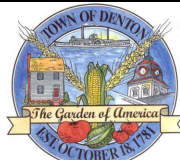

**PIPE BEDDING AND BACKFILL DETAIL**

TOWN OF DENTON DEPARTMENT OF PUBLIC WORKS	 	STORM DRAIN DETAILS PIPE BEDDING & BACKFILL	REVISED	SHEET
			DEC 2007	
			APR 2021	
			SD-3.00	

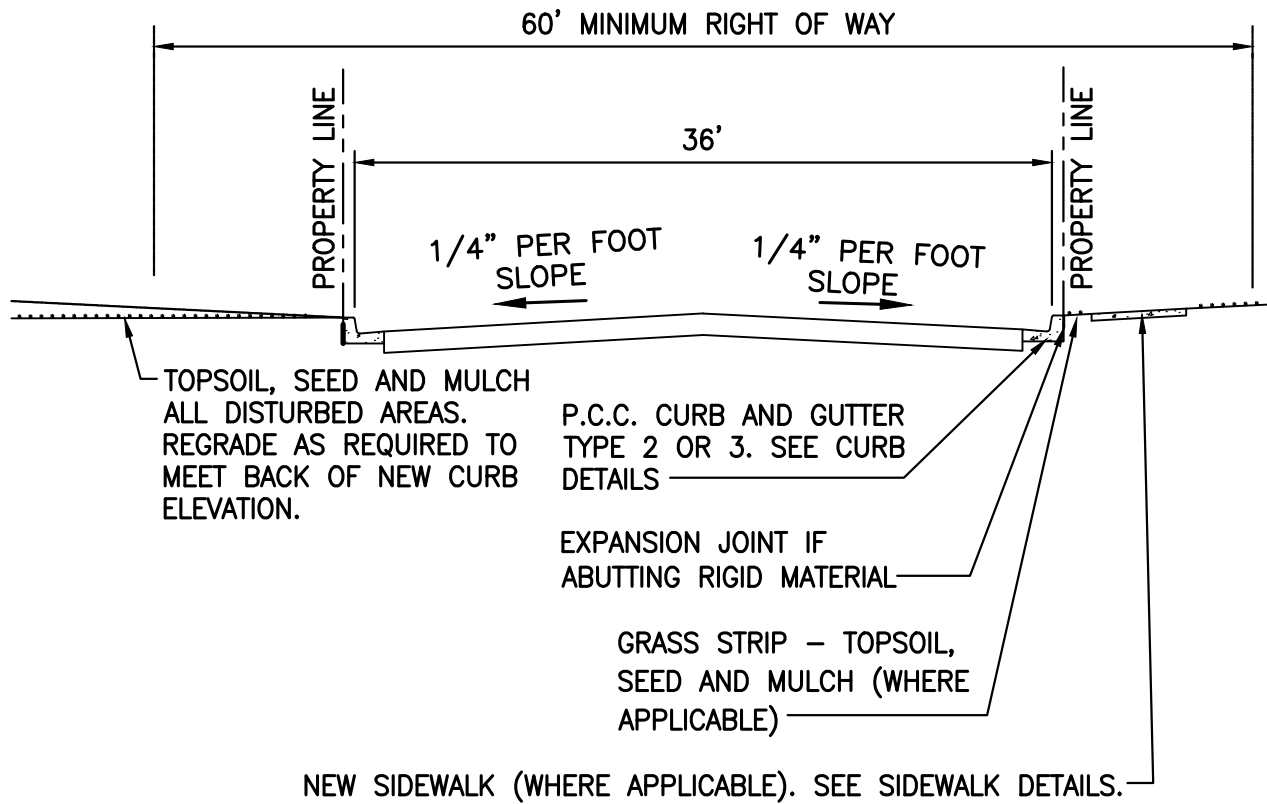

### RIGHT OF WAY SECTION

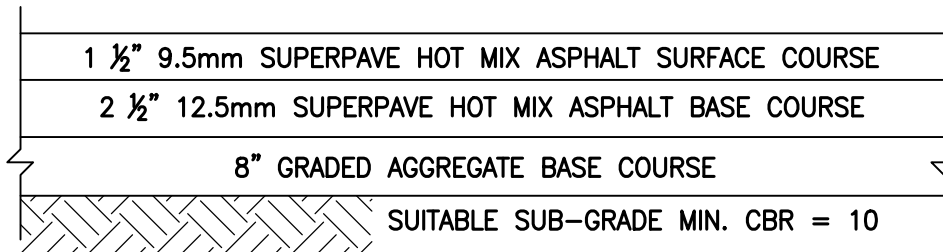

### PAVING SECTION

**NOTES:**

1. BASE & SUB-BASE COURSES TO BE COMPACTED TO MIN. 95% MODIFIED PROCTOR PER ASTM D-1557.
2. SOIL STABILIZATION (SOIL CEMENT), GEOTEXTILES / FABRICS FOR BASE STABILIZATION MAY BE CONSIDERED ONLY AFTER SPECIFIC APPROVAL FROM TOWN OF DENTON DPW.
3. PAVEMENT THICKNESS PER PAVEMENT DESIGN AS APPLICABLE.

TOWN OF  
DENTON  
DEPARTMENT  
OF  
PUBLIC WORKS



PAVEMENT & CONCRETE DETAILS  
COLLECTOR STREETS  
RESIDENTIAL AREAS

REVISED  
DEC 2007  
APR 2021

SHEET  
PW-1.00

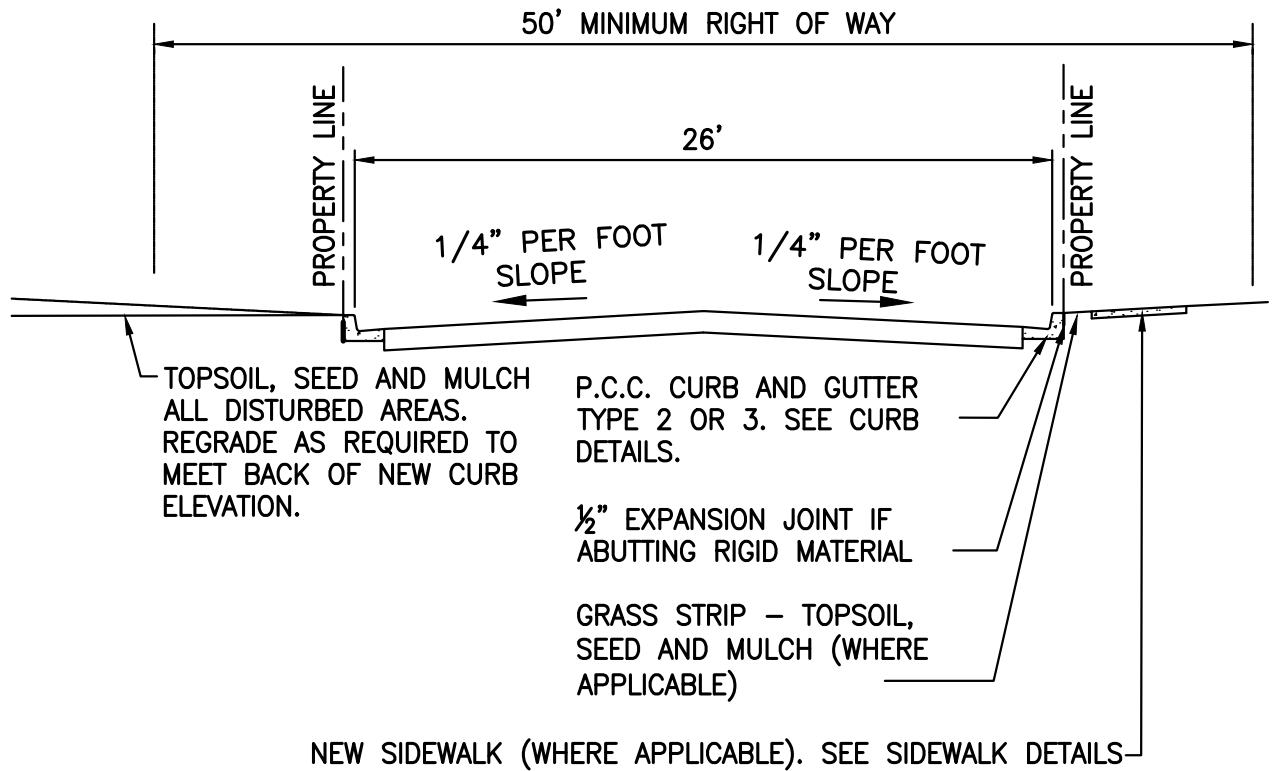

### RIGHT OF WAY SECTION

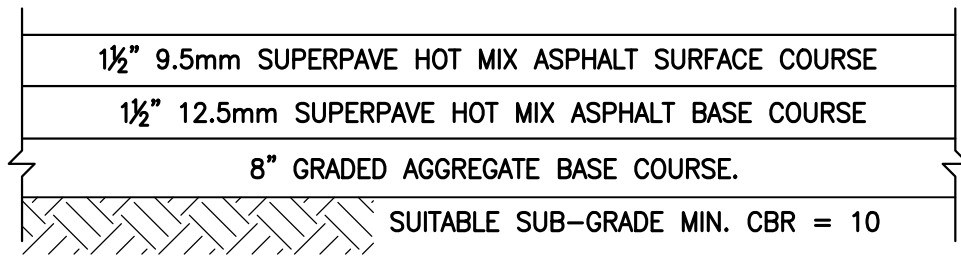

### PAVING SECTION

**NOTES:**

1. BASE & SUB-BASE COURSES TO BE COMPACTED TO MIN. 95% MODIFIED PROCTOR PER ASTM D-1557.
2. SOIL STABILIZATION (SOIL CEMENT), GEOTEXTILES / FABRICS FOR BASE STABILIZATION MAY BE CONSIDERED ONLY AFTER SPECIFIC APPROVAL FROM TOWN OF DENTON DPW.
3. PAVEMENT THICKNESS PER PAVEMENT DESIGN AS APPLICABLE.

TOWN OF  
DENTON  
DEPARTMENT  
OF  
PUBLIC WORKS



PAVEMENT & CONCRETE DETAILS  
MINOR STREETS IN SINGLE  
FAMILY RESIDENTIAL AREAS

REVISED
DEC 2007
APR 2021

SHEET  
PW-1.10

G:\Projects\2020\200110 Town of Denton On-Call Services 2020-2025 Standards & Specs Revised 2021 (CMB)\Manual\DETAILS\CAD\PAVEMENT & CONCRETE.dwg May 04, 2021 - 3:25pm

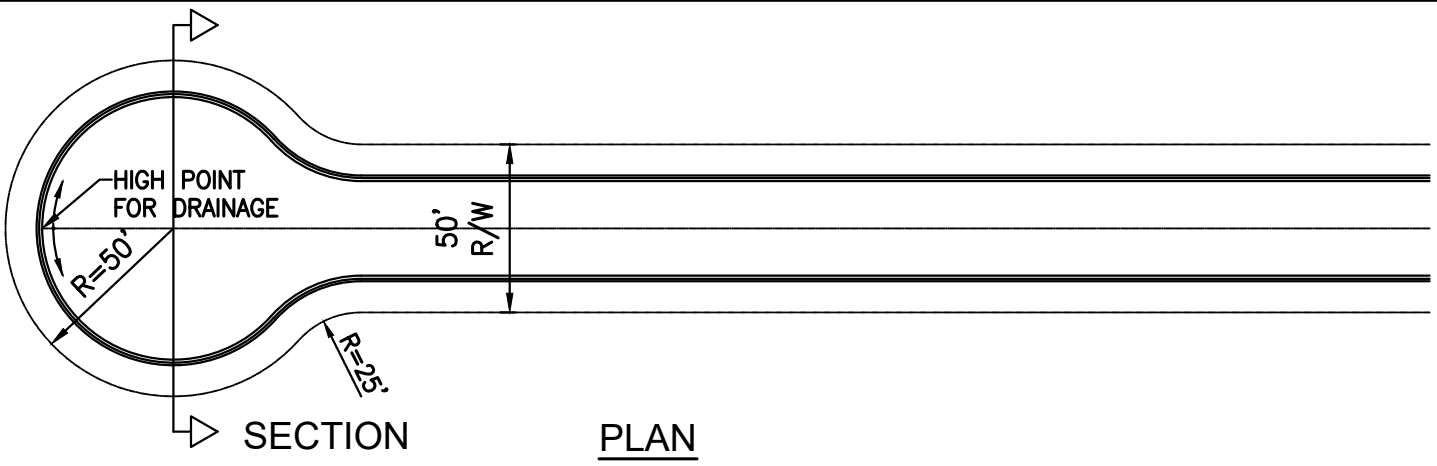

**SECTION** PLAN

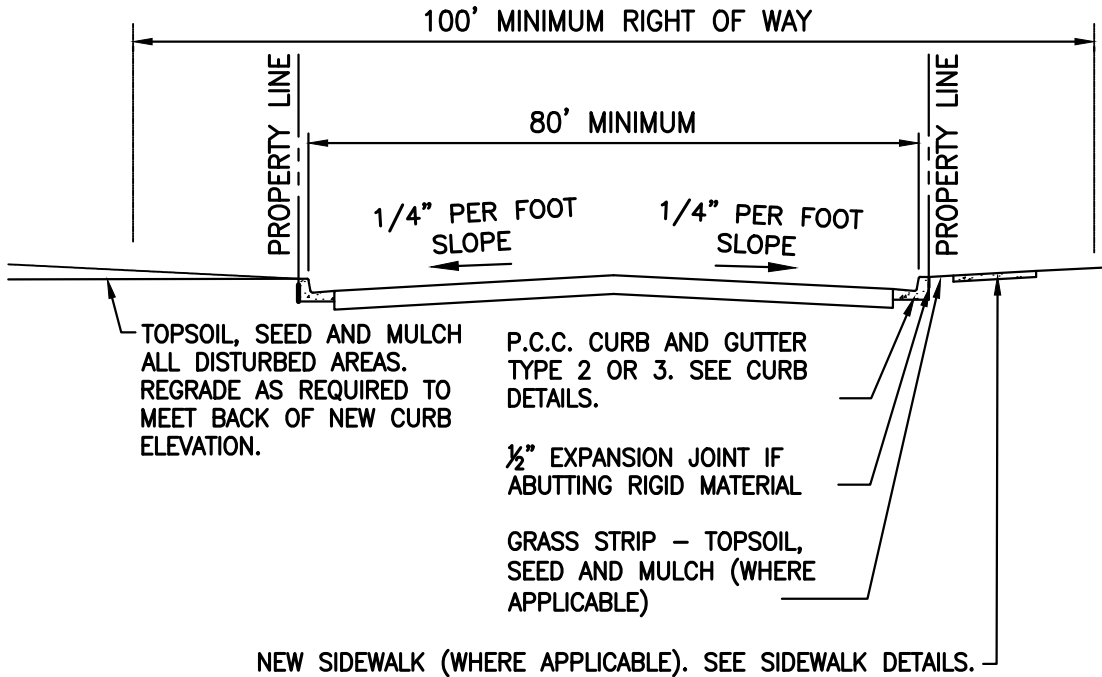

**NOTE:**  
 MAXIMUM LENGTH OF CUL-DE-SAC STREET: 600 FEET, AS MEASURED ALONG CENTERLINE STATIONING

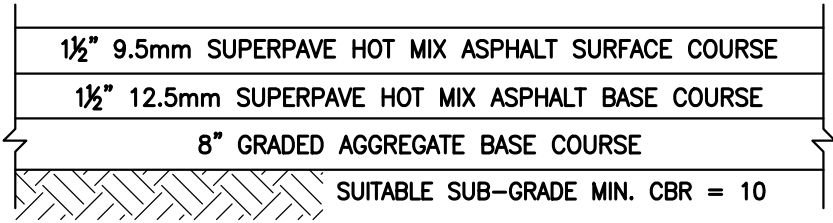

RIGHT OF WAY SECTION



**NOTES:**

PAVING SECTION

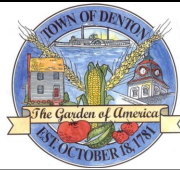
1. BASE & SUB-BASE COURSES TO BE COMPACTED TO MIN. 95% MODIFIED PROCTOR PER ASTM D-1557.
2. SOIL STABILIZATION (SOIL CEMENT), GEOTEXTILES / FABRICS FOR BASE STABILIZATION MAY BE CONSIDERED ONLY AFTER SPECIFIC APPROVAL FROM TOWN OF DENTON DPW.
3. PAVEMENT THICKNESS PER PAVEMENT DESIGN, AS APPLICABLE.

TOWN OF DENTON DEPARTMENT OF PUBLIC WORKS	 	PAVEMENT & CONCRETE DETAILS  CUL-DE-SAC IN SINGLE FAMILY RESIDENTIAL AREAS	REVISED	SHEET  PW-1.20
			DEC 2007	
			APR 2021	

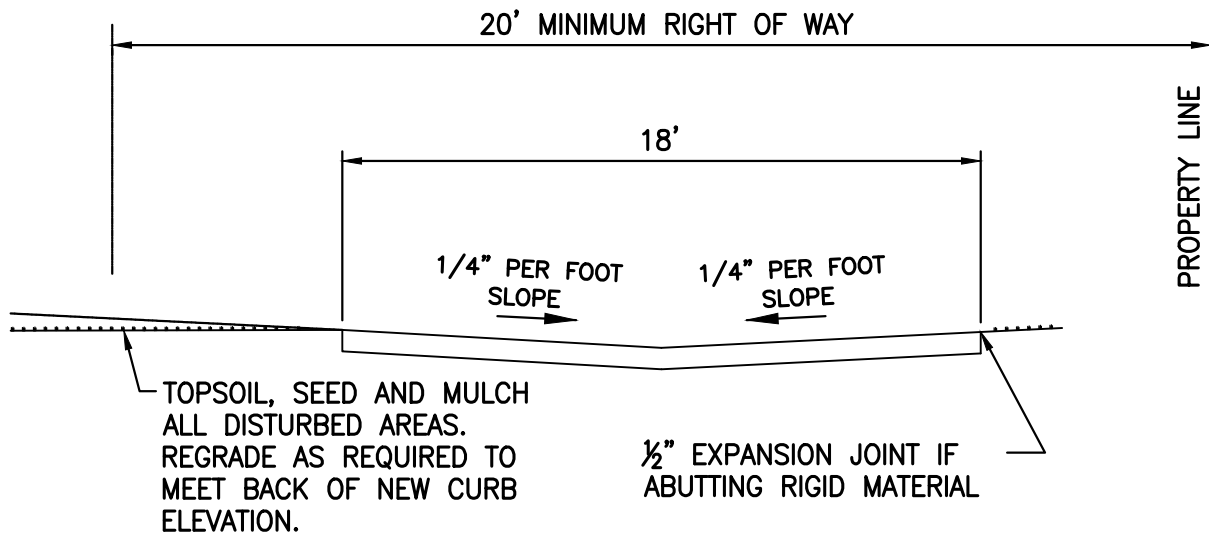

RIGHT OF WAY SECTION

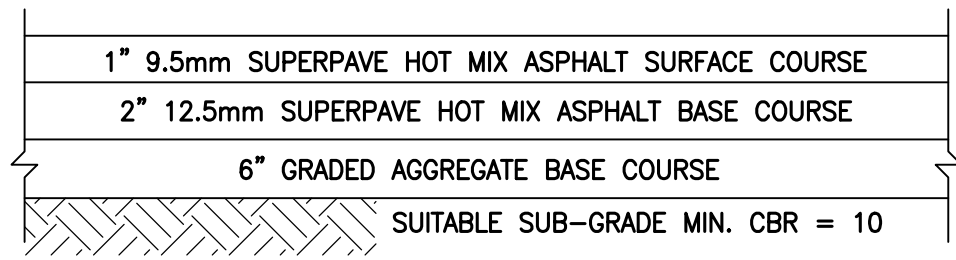



PAVING SECTION

NOTES:

1. BASE & SUB-BASE COURSES TO BE COMPACTED TO MIN. 95% MODIFIED PROCTOR PER ASTM D-1557.
2. SOIL STABILIZATION (SOIL CEMENT), GEOTEXTILES / FABRICS FOR BASE STABILIZATION MAY BE CONSIDERED ONLY AFTER SPECIFIC APPROVAL FROM TOWN OF DENTON DPW.
3. PAVEMENT THICKNESS PER PAVEMENT DESIGN AS APPLICABLE.

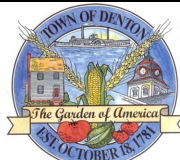
G:\Projects\2020\200110 Town of Denton On-Call Services 2020-2025\Standards & Specs\Revised 2021 (CMB)\Manual\DETAILS\CAD\PAVEMENT & CONCRETE.dwg May 04, 2021 - 3:25pm

TOWN OF DENTON DEPARTMENT OF PUBLIC WORKS	 	PAVEMENT & CONCRETE DETAILS  RESIDENTIAL ALLEY	REVISED	SHEET  PW-1.30
			DEC 2007	
			APR 2021	

G:\Projects\2020\200110 Town of Denton On-Call Services 2020-2025\Standards & Specs\Revised 2021 (CHB)\Manual\DETAILS\CAD\PAVEMENT & CONCRETE.dwg May 04, 2021 - 3:25pm

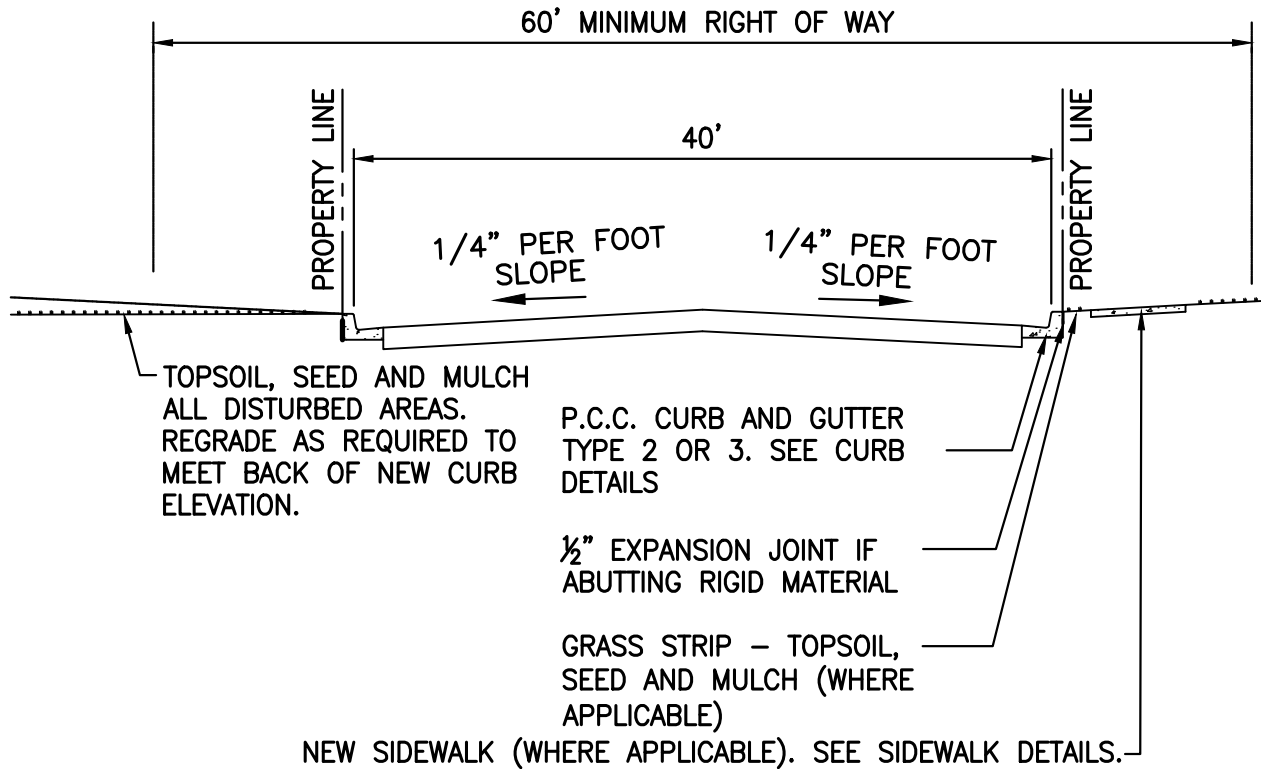

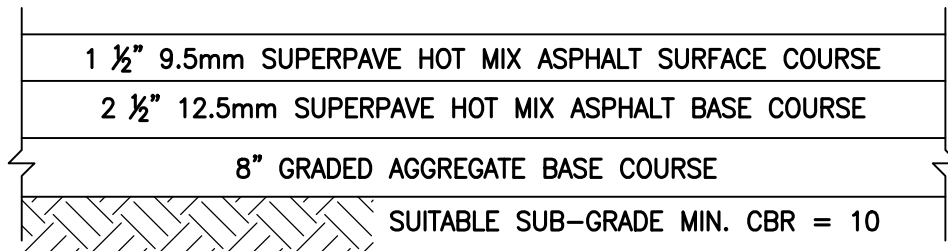

### RIGHT OF WAY SECTION



### PAVING SECTION

**NOTES:**

1. BASE & SUB-BASE COURSES TO BE COMPACTED TO MIN. 95% MODIFIED PROCTOR PER ASTM D-1557.
2. SOIL STABILIZATION (SOIL CEMENT), GEOTEXTILES / FABRICS FOR BASE STABILIZATION MAY BE CONSIDERED ONLY AFTER SPECIFIC APPROVAL FROM TOWN OF DENTON DPW.
3. PAVEMENT THICKNESS PER PAVEMENT DESIGN AS APPLICABLE.

<b>TOWN OF DENTON DEPARTMENT OF PUBLIC WORKS</b>	 	<b>PAVEMENT &amp; CONCRETE DETAILS</b>  COLLECTOR STREETS  COMMERCIAL & INDUSTRIAL AREAS	REvised	<b>SHEET</b>  PW-1.40
			DEC 2007	
			APR 2021	

G:\Projects\2020\200110 Town of Denton On-Call Services 2020-2025\Standards & Specs\Revised 2021 (CMB)\Manual\DETAILS\CAD\PAVEMENT & CONCRETE.dwg May 04, 2021 - 3:25pm

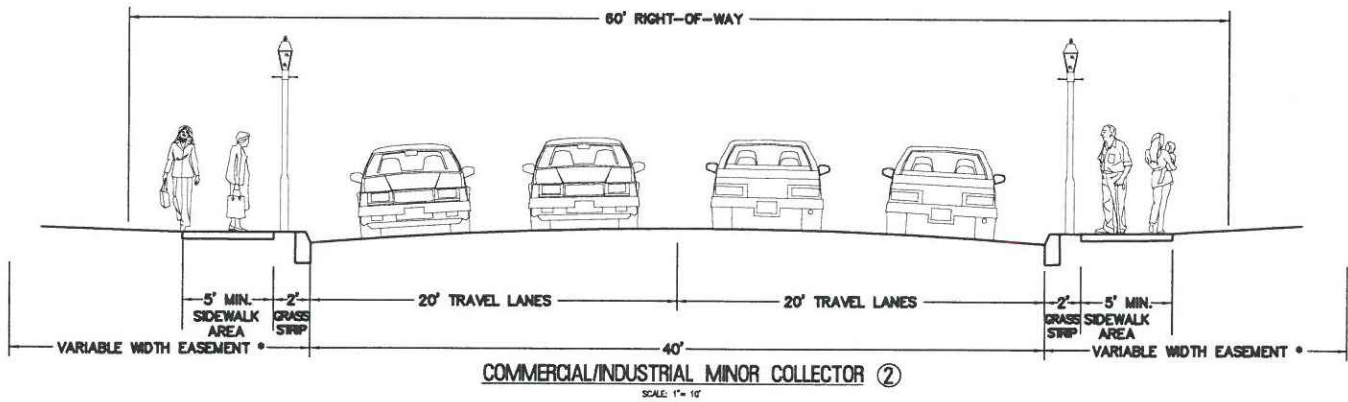
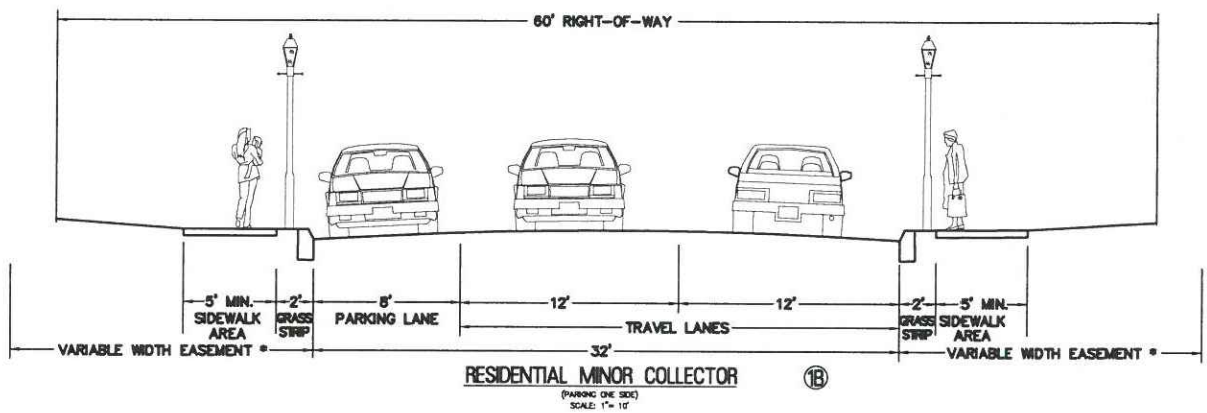
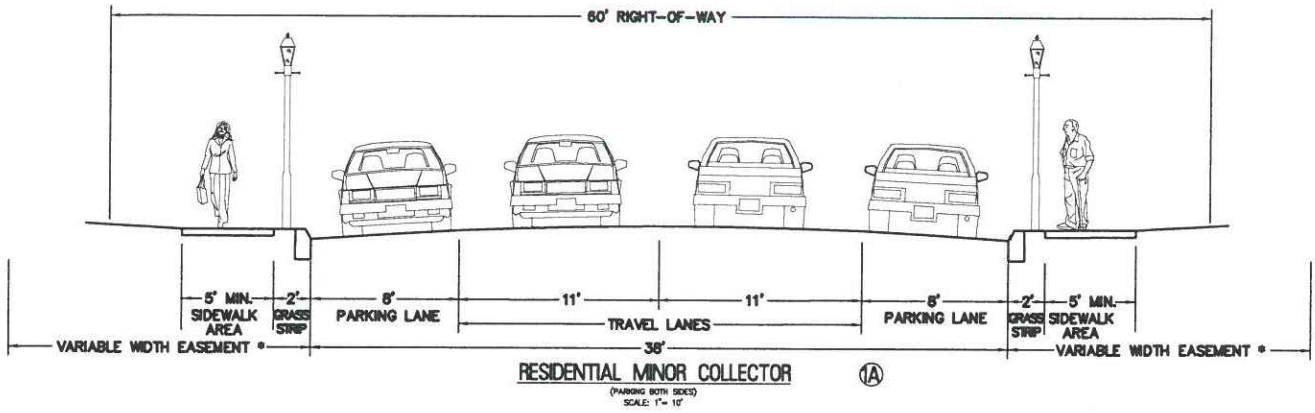

**TOWN OF DENTON  
 DEPARTMENT  
 OF  
 PUBLIC WORKS**

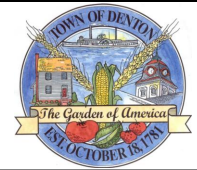

**PAVEMENT & CONCRETE DETAILS**  
 STANDARD ROAD  
 CROSS-SECTION DETAILS  
 1 OF 2

REVISED
DEC 2007
APR 2021

**SHEET**  
 PW-1.50

G:\Projects\2020\200110 Town of Denton On-Call Services 2020-2025\Standards & Specs\Revised 2021 (CHB)\Manual\DETAILS\CAD\PAVEMENT & CONCRETE.dwg May 04, 2021 - 3:26pm

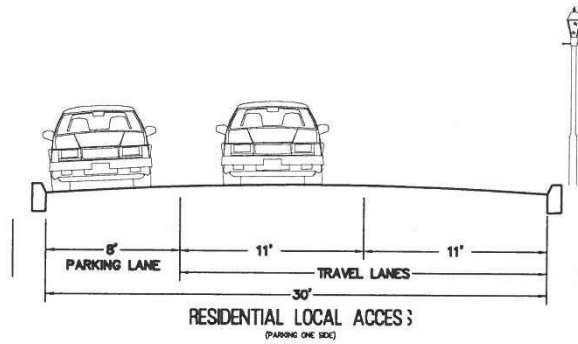
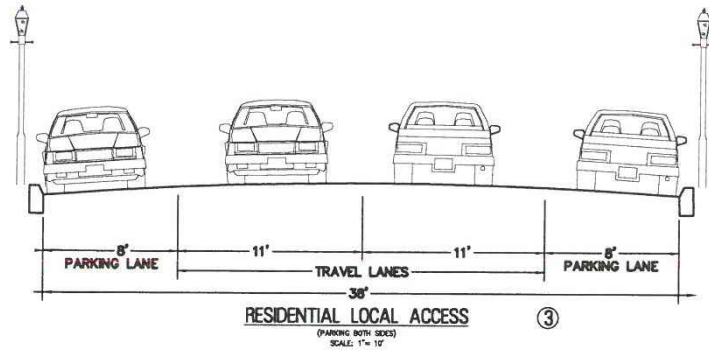

TOWN OF  
DENTON  
DEPARTMENT  
OF  
PUBLIC WORKS



PAVEMENT & CONCRETE DETAILS  
STANDARD ROAD  
CROSS-SECTION DETAILS  
2 OF 2

REVISED
DEC 2007
APR 2021

SHEET  
PW-1.60



G:\Projects\2020\200110 Town of Denton On-Call Services 2020-2025\Standards & Specs\Revised 2021 (CMB)\Manual\DETAILS\CAD\PAVEMENT & CONCRETE.dwg May 04, 2021 - 3:26pm

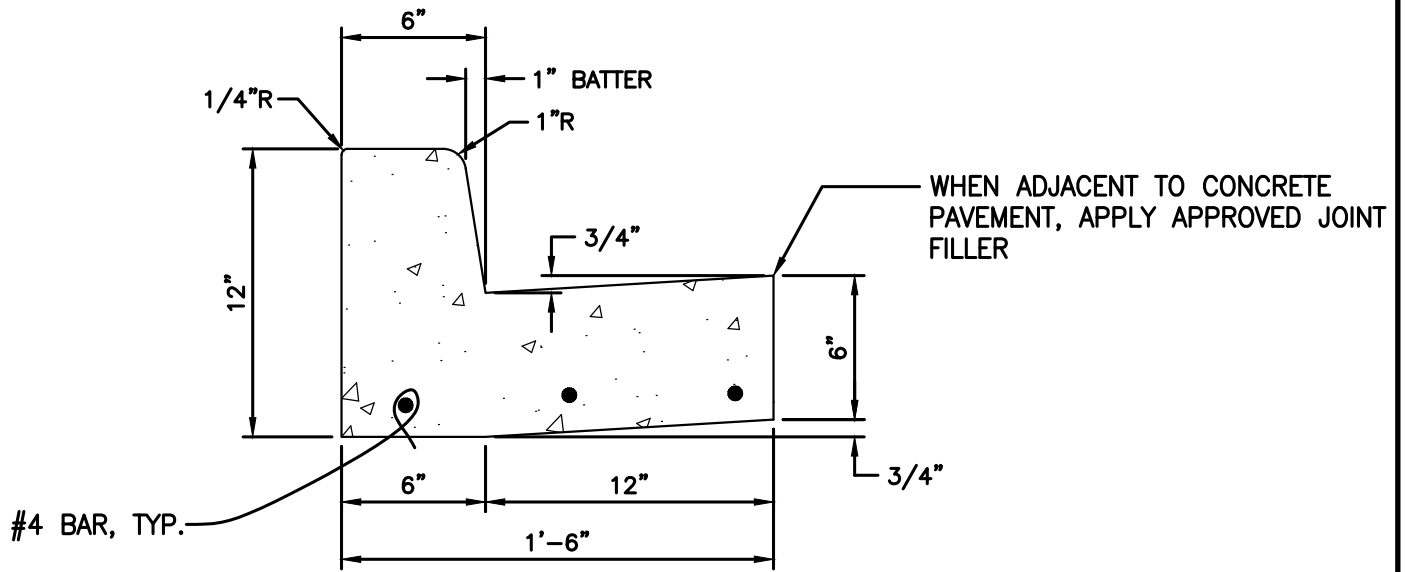

STANDARD CURB AND GUTTER

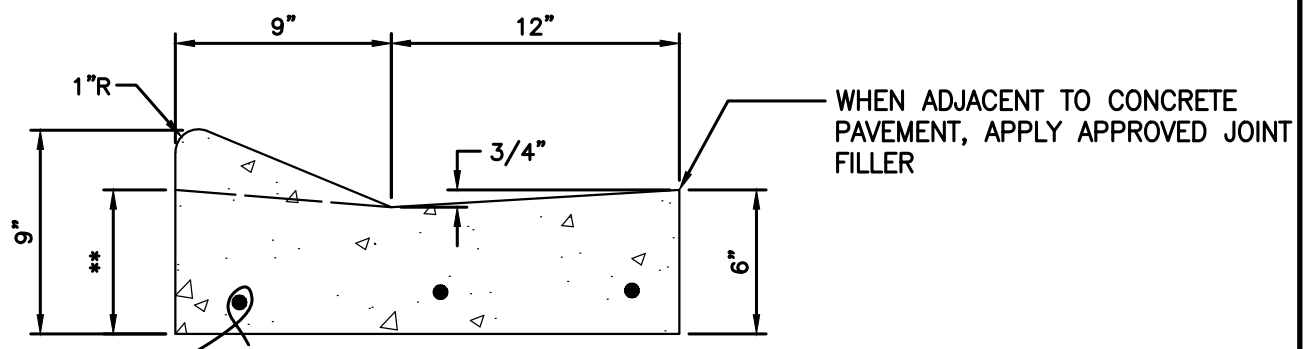



MOUNTABLE CURB AND GUTTER

#4 BAR, TYP.

NOTES:

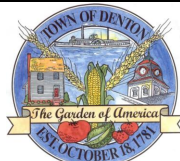

1. CURBING SHALL BE INSTALLED ON MINIMUM 8" GRADED AGGREGATE BASE ON SUITABLE SUBGRADE COMPACTED TO MINIMUM 95% MODIFIED PROCTOR PER ASTM D-1557.
2. ALL CONCRETE USED FOR CURB AND GUTTER SHALL BE 3000 PSI.
3. CURB AND GUTTER SHALL HAVE CONTRACTION JOINTS EVERY 10'-0" AND EXPANSION JOINTS EVERY 40'-0". EXTRUDED CONCRETE CURB AND GUTTER SHALL HAVE CONTRACTION JOINTS EVERY 10'-0", AND EXPANSION JOINTS EVERY 100'-0".
- \*\* 4. CURB HEIGHT SHALL BE 6" AT HANDICAP RAMPS.

TOWN OF DENTON DEPARTMENT OF PUBLIC WORKS	 	PAVEMENT & CONCRETE DETAILS  COMBINATION CONCRETE  CURB & GUTTER	REVISED	SHEET  PW-2.00
			DEC 2007	
			NOV. 2009	
			APR 2021	

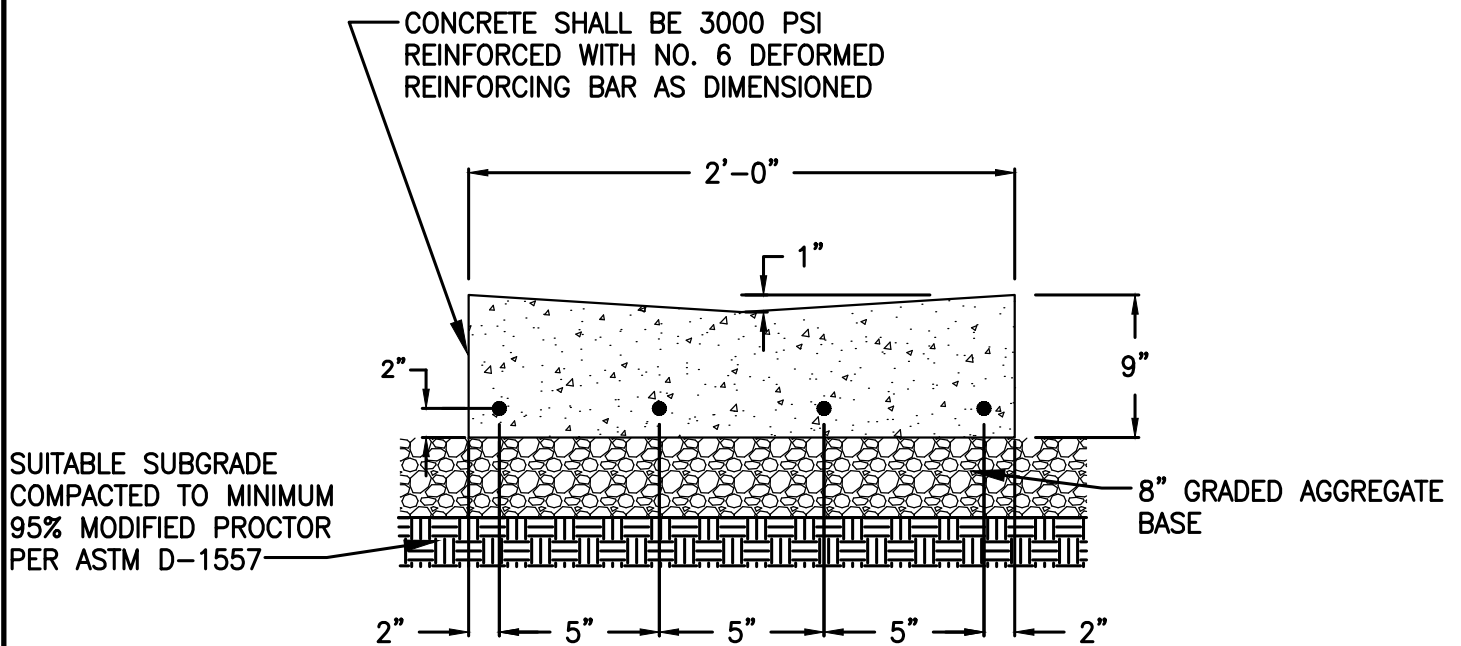
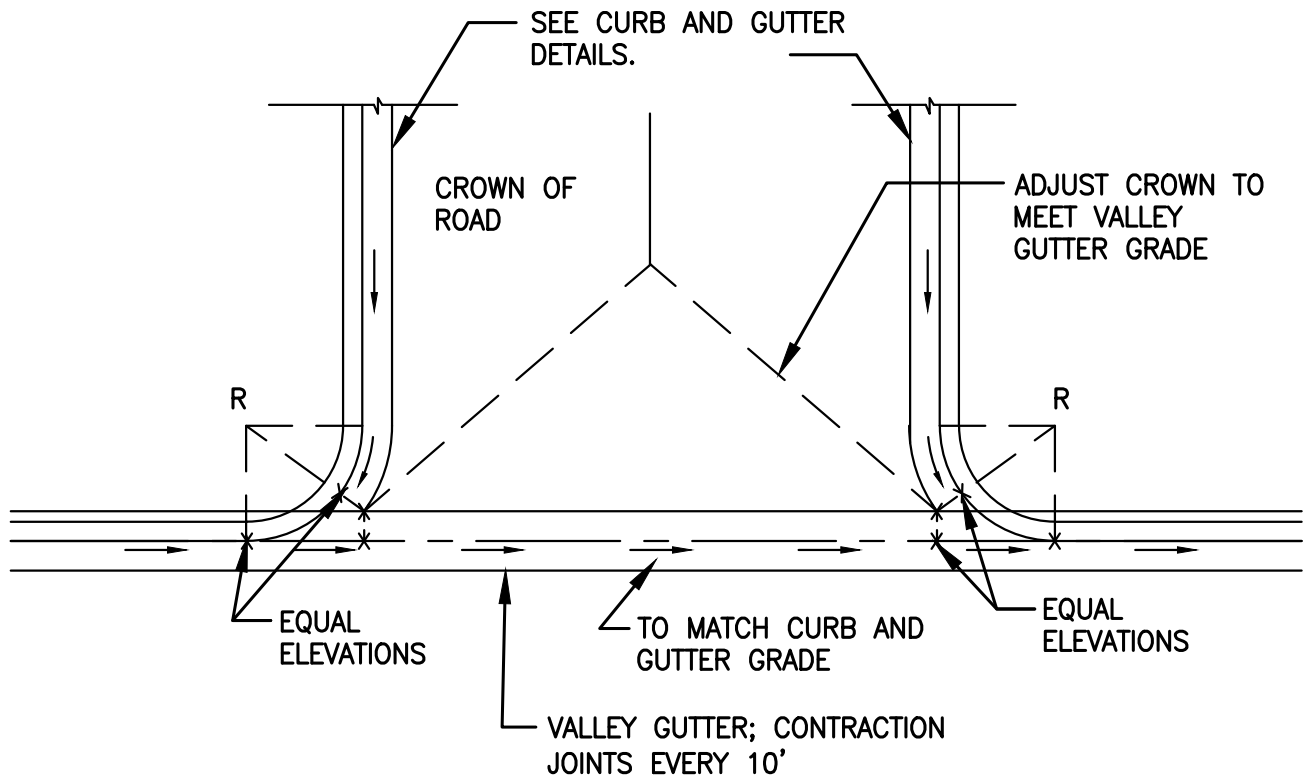
C:\Projects\2020\200110 Town of Denton On-Call Services 2020-2025 Standards & Specs (Revised 2021) (CHB)\Manual\DETAILS\CAD\PAVEMENT & CONCRETE.dwg May 04, 2021 - 3:26pm



**VALLEY GUTTER**

TOWN OF DENTON DEPARTMENT OF PUBLIC WORKS	 	PAVEMENT & CONCRETE DETAILS VALLEY GUTTER AND INTERSECTION DETAIL	REVISED	SHEET
			DEC 2007	
			APR 2021	
			PW-3.00	

C:\Projects\2020\200110 Town of Denton On-Call Services 2020-2025 Standards & Specs\Revised 2021 (CHB)\Manual\DETAILS\CAD\PAVEMENT & CONCRETE.dwg May 04, 2021 - 3:28pm

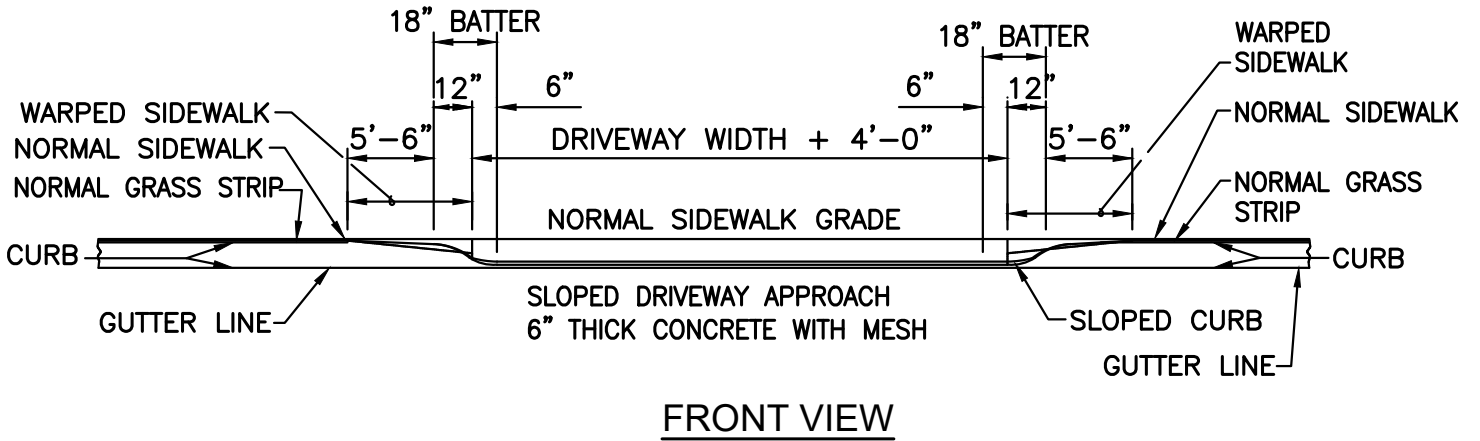
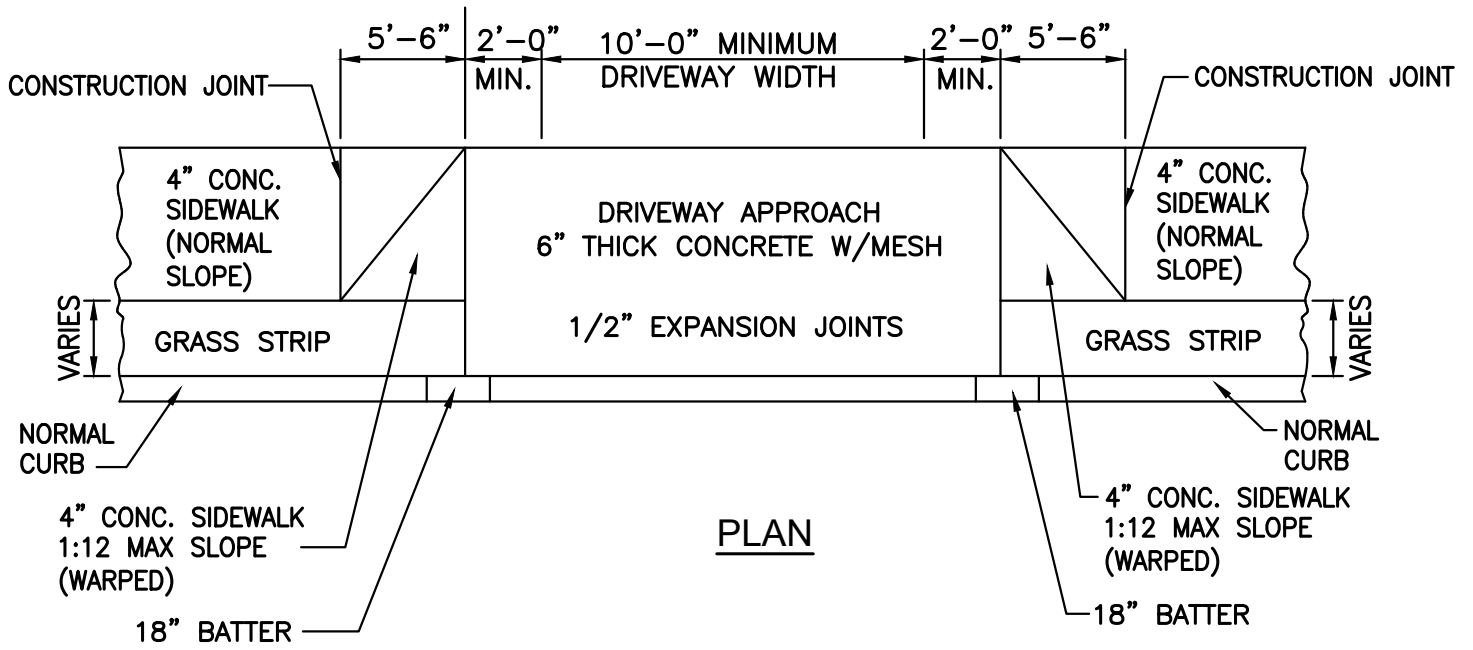

**NOTES:**

1. ALL SIDEWALK AND DRIVEWAY ENTRANCES SHALL MEET A.D.A. REQUIREMENTS.
2. REFER TO TYPICAL SIDEWALKS DETAILS.

TOWN OF  
 DENTON  
 DEPARTMENT  
 OF  
 PUBLIC WORKS



PAVEMENT & CONCRETE DETAILS  
 TYPICAL DRIVEWAY ENTRANCE  
 WITH GRASS STRIP

REVISED  
 DEC 2007

SHEET  
 PW-4.00

C:\Projects\2020\200110 Town of Denton On-Call Services 2020-2025\Standards & Specs\Revised 2021 (CHB)\Manual\DETAILS\CAD\PAVEMENT & CONCRETE.dwg May 04, 2021 - 3:26pm

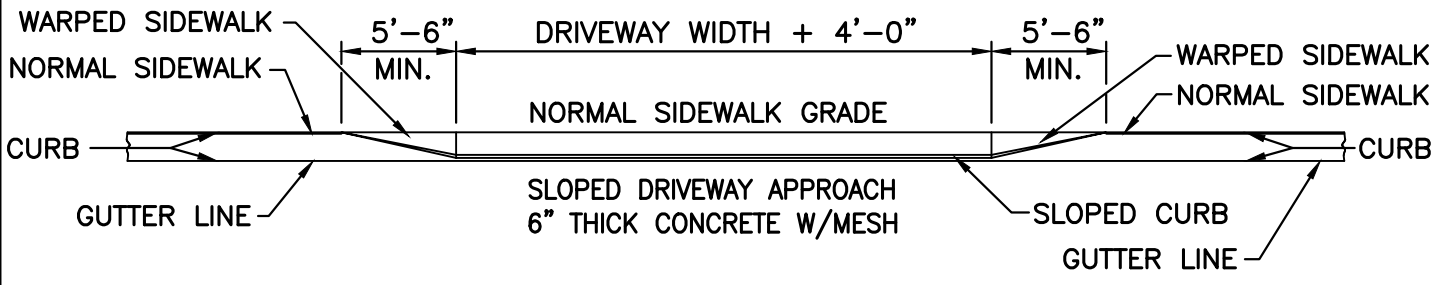
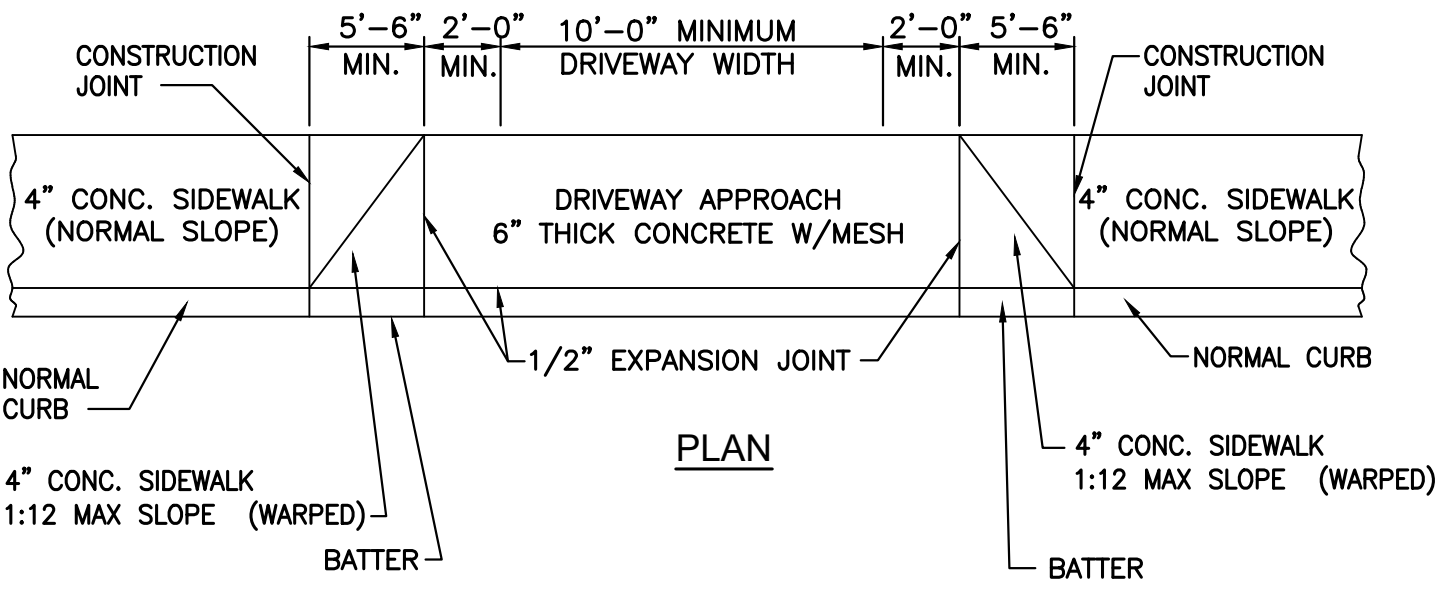

**NOTES:**

1. ALL SIDEWALK AND DRIVEWAY ENTRANCES SHALL MEET A.D.A. REQUIREMENTS.
2. REFER TO TYPICAL SIDEWALK DETAIL.

TOWN OF DENTON DEPARTMENT OF PUBLIC WORKS	 The Garden of America EST. OCTOBER 18, 1791	 DENTON PUBLIC WORKS	PAVEMENT & CONCRETE DETAILS		REVISED	SHEET
			TYPICAL DRIVEWAY ENTRANCE		DEC 2007	
			WITHOUT GRASS STRIP			
					PW-4.10	

C:\Projects\2020\200110 Town of Denton On-Call Services 2020-2025 Standards & Specs Revised 2021 (CHB)\Manual\DETAILS\CAD\PAVEMENT & CONCRETE.dwg May 04, 2021 - 3:26pm

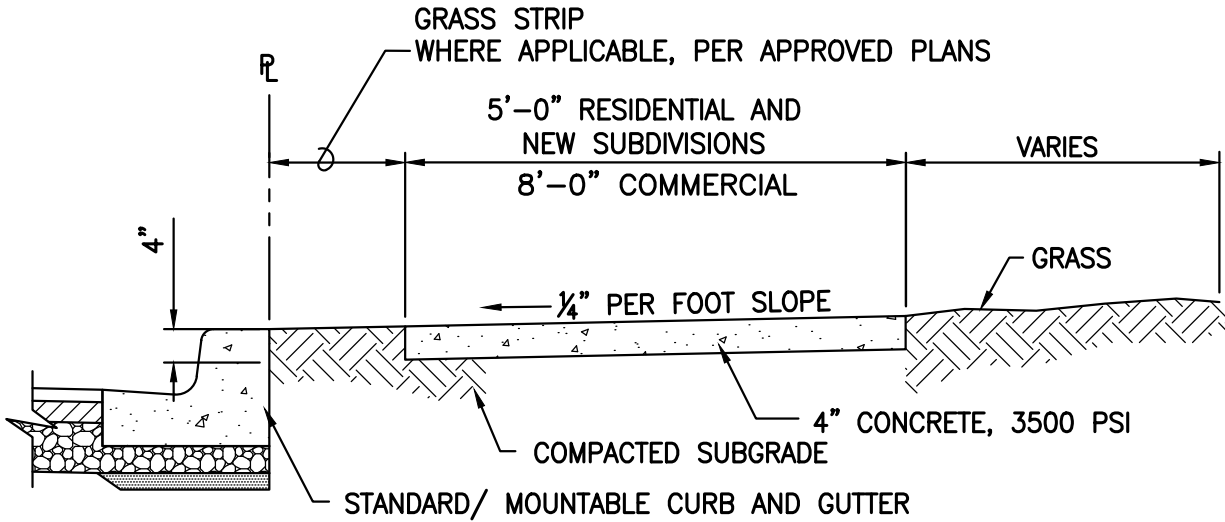

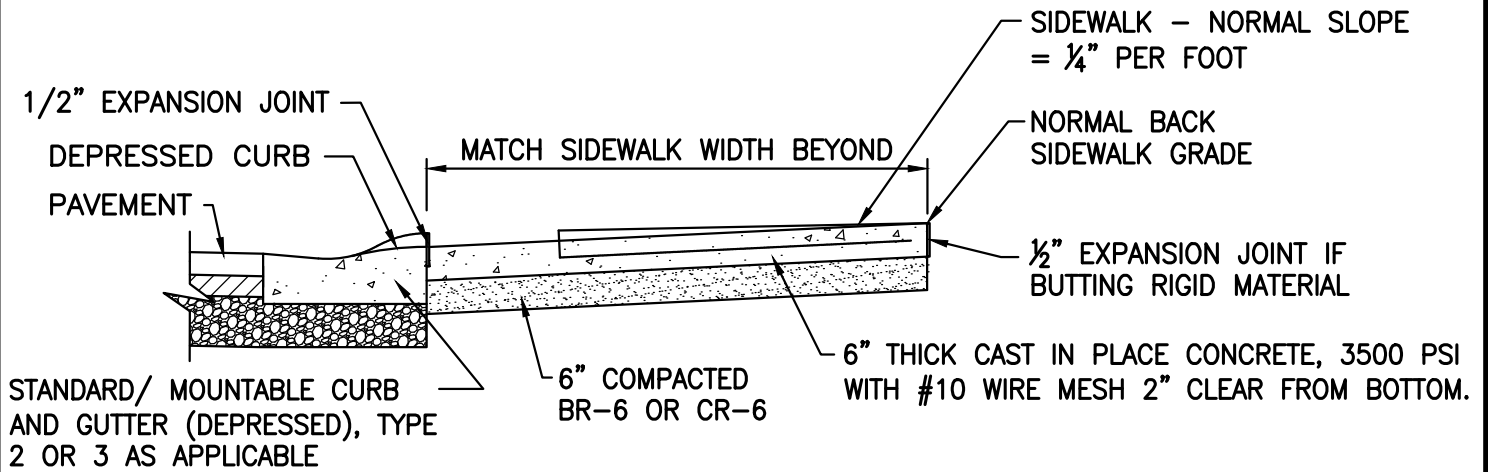

**TYPICAL SIDEWALK INSTALLATION**



**TYPICAL SIDEWALK AT DRIVEWAY ENTRANCE**

**NOTES:**

1. CONSTRUCT 1/2" EXPANSION JOINT WHERE CONCRETE ABUTS RIGID PAVEMENT, CURB AND/OR WALL.
2. TOPSOIL, SEED AND MULCH ALL DISTURBED AREAS. REGRADE AS REQUIRED TO MEET BACK OF CURB ELEVATION.

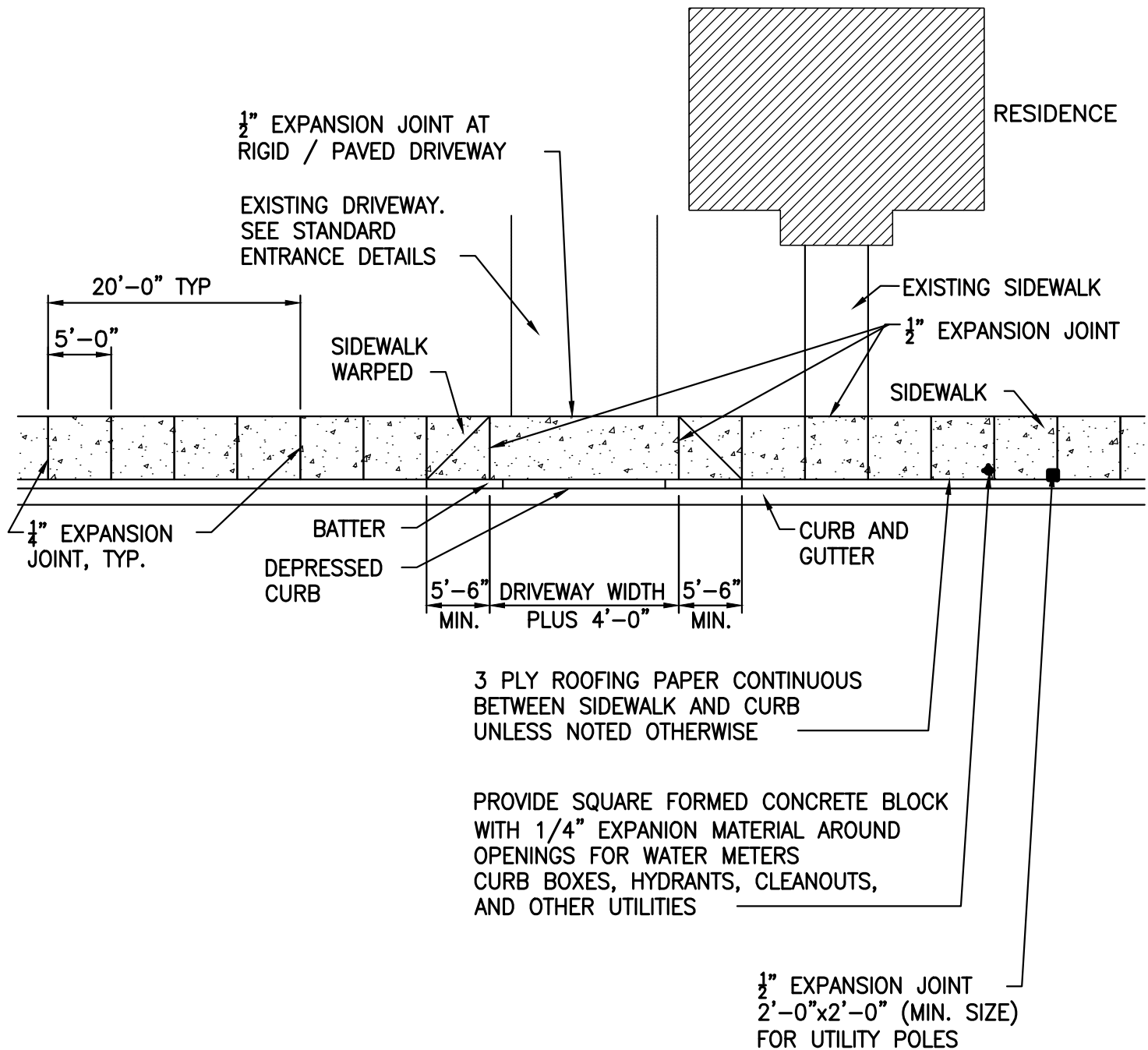

TOWN OF DENTON DEPARTMENT OF PUBLIC WORKS	 	PAVEMENT & CONCRTE DETAILS  TYPICAL SIDEWALKS	REVISED	SHEET  PW-5.00
			DEC 2007	
			APR 2021	

G:\Projects\2020\200110 Town of Denton On-Call Services 2020-2025 Standards & Specs Revised 2021 (CHB)\Manual\DETAILS\CAD\PAVEMENT & CONCRETE.dwg May 04, 2021 - 3:26pm



**NOTES:**

1. CONCRETE SHALL BE 3500 PSI
2. CONTRACTION JOINTS AT 5' INTERVALS
3. 1/4" THICK, FULL DEPTH EXPANSION JOINTS AT INTERVALS NOT GREATER THAN 20'
4. REFER TO OTHER SIDEWALK AND DRIVEWAY STANDARD DETAILS

TOWN OF DENTON DEPARTMENT OF PUBLIC WORKS	 	PAVEMENT & CONCRTE DETAILS  TYPICAL CURB, GUTTER & SIDEWALK EXPANSION JOINTS	REVISED	SHEET  PW-5.10
			DEC 2007	

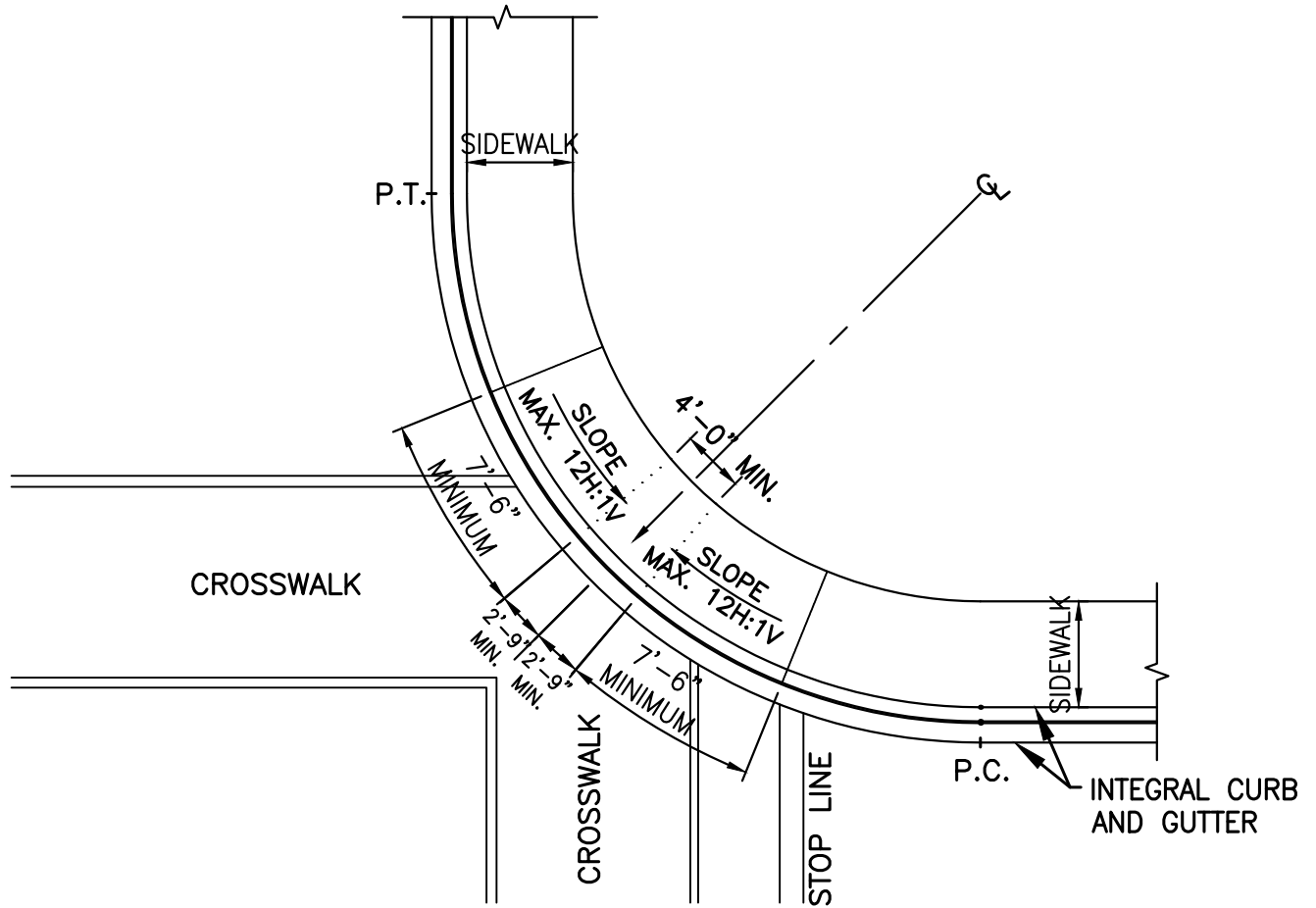

PLAN

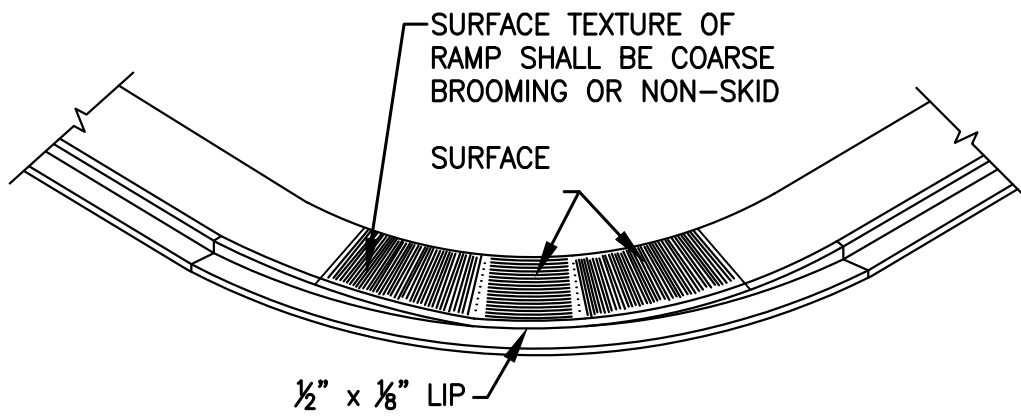

ISOMETRIC

**NOTES:**

1. ALL HANDICAP RAMPS SHALL BE A.D.A. COMPLIANT.
2. NO SLOPE SHALL EXCEED 12H:1V ON THE RAMP OR SIDEWALK.

TOWN OF DENTON DEPARTMENT OF PUBLIC WORKS			PAVEMENT & CONCRTE DETAILS	REVISED	SHEET
			HANDICAP RAMP	DEC 2007	PW-6.00

C:\Projects\2020\200110 Town of Denton On-Call Services 2020-2025\Standards & Specs\Revised 2021 (CHB)\Manual\DETAILS\CAD\PAVEMENT & CONCRETE.dwg May 04, 2021 - 3:26pm

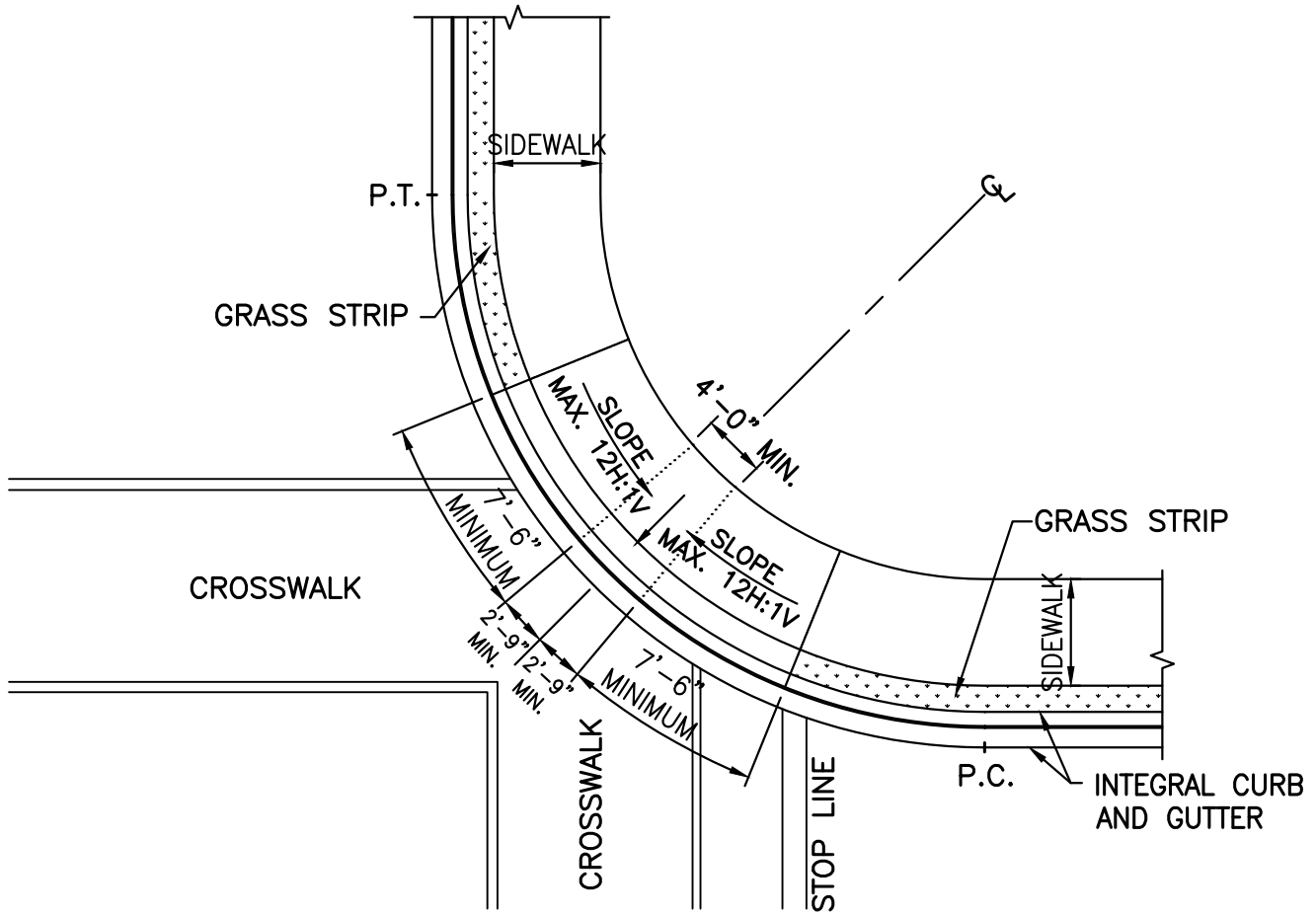

**PLAN**

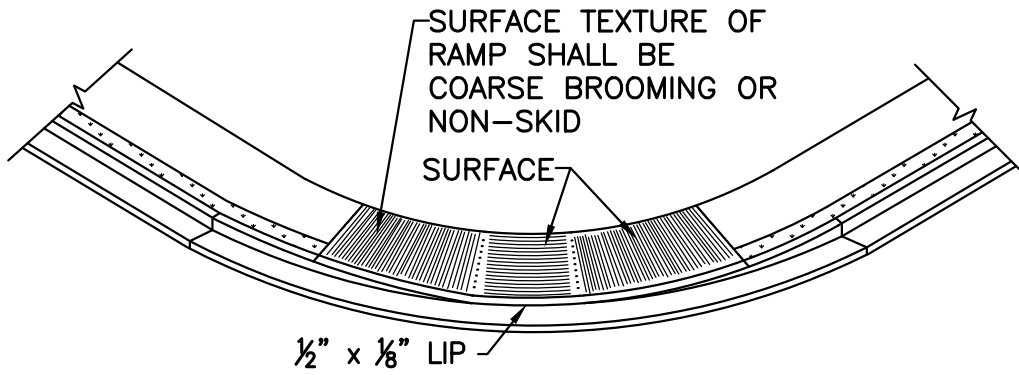

**ISOMETRIC**

**NOTES:**

1. ALL HANDICAP RAMPS SHALL BE A.D.A. COMPLIANT.
2. NO SLOPE SHALL EXCEED 12H:1V ON THE RAMP OR SIDEWALK.



TOWN OF DENTON DEPARTMENT OF PUBLIC WORKS	 	PAVEMENT & CONCRTE DETAILS  HANDICAP RAMP WITH GRASS STRIP	REVISED	SHEET  PW-6.10
			DEC 2007	

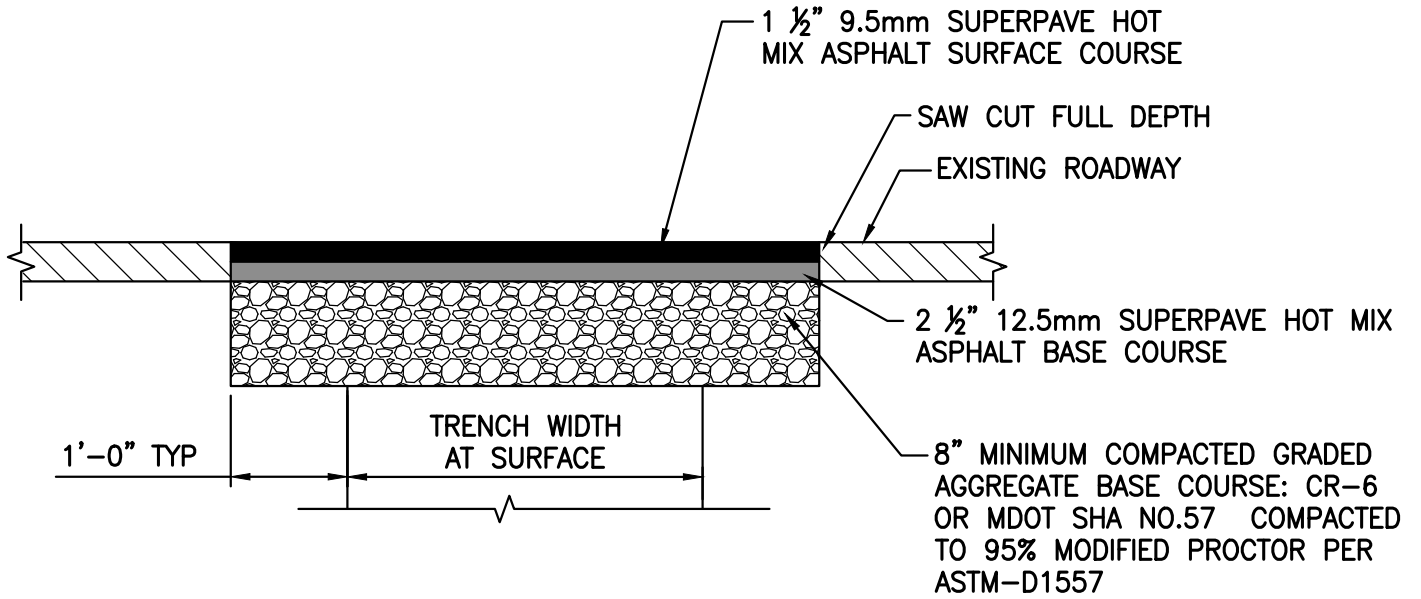

G:\Projects\2020\200110 Town of Denton On-Call Services 2020-2025\Standards & Specs\Revised 2021 (CHB)\Manual\DETAILS\CAD\PAVEMENT & CONCRETE.dwg May 04, 2021 - 3:26pm



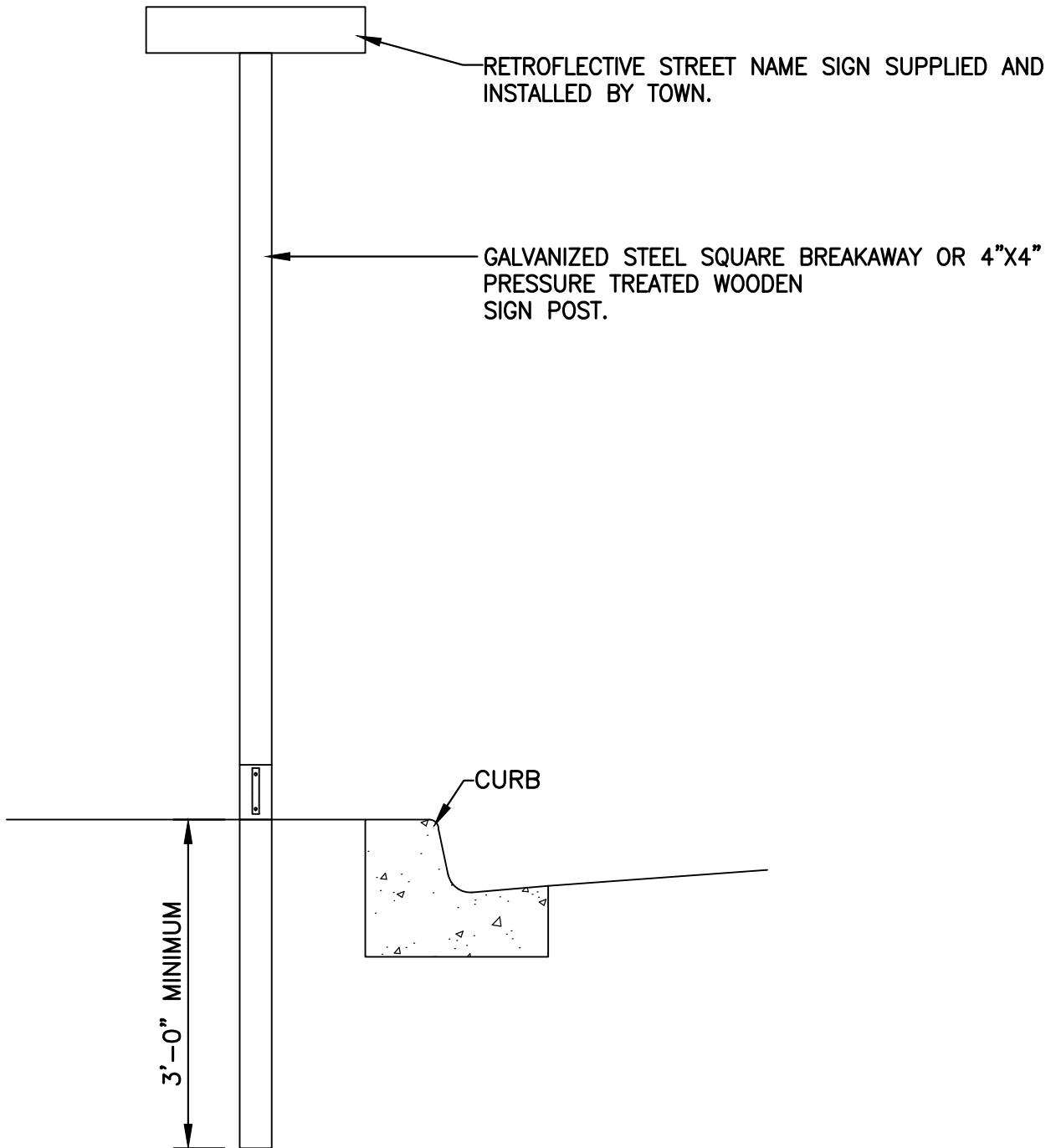

PAVEMENT RESTORATION DETAIL

<p>TOWN OF DENTON DEPARTMENT OF PUBLIC WORKS</p>	 	<p>PAVEMENT &amp; CONCRTE DETAILS</p> <p>PAVEMENT RESTORATION</p>	REVISED	SHEET
			DEC 2007	
			APR 2021	
			PW-7.00	



**NOTES:**

1. SIGN POST SHALL BE NUCOR MARION STEEL COMPANY "LAP SPLICE BREAKAWAY SYSTEM" MODEL OR AN APPROVED EQUAL.
2. SIGN HEIGHT AND PLACEMENT SHALL BE IN ACCORDANCE WITH THE CURRENT "MANUAL OF UNIFORM TRAFFIC CONTROL DEVICES" (MUTCD).
3. FOR PRIVATE SUBDIVISION / DEVELOPMENT PROJECTS ALL SIGNAGE COSTS BORNE BY DEVELOPER.

TOWN OF DENTON DEPARTMENT OF PUBLIC WORKS	 	PAVEMENT & CONCRTE DETAILS  STREET NAME SIGN	REVISED	SHEET  PW-8.00
			DEC 2007	
			APR 2021	

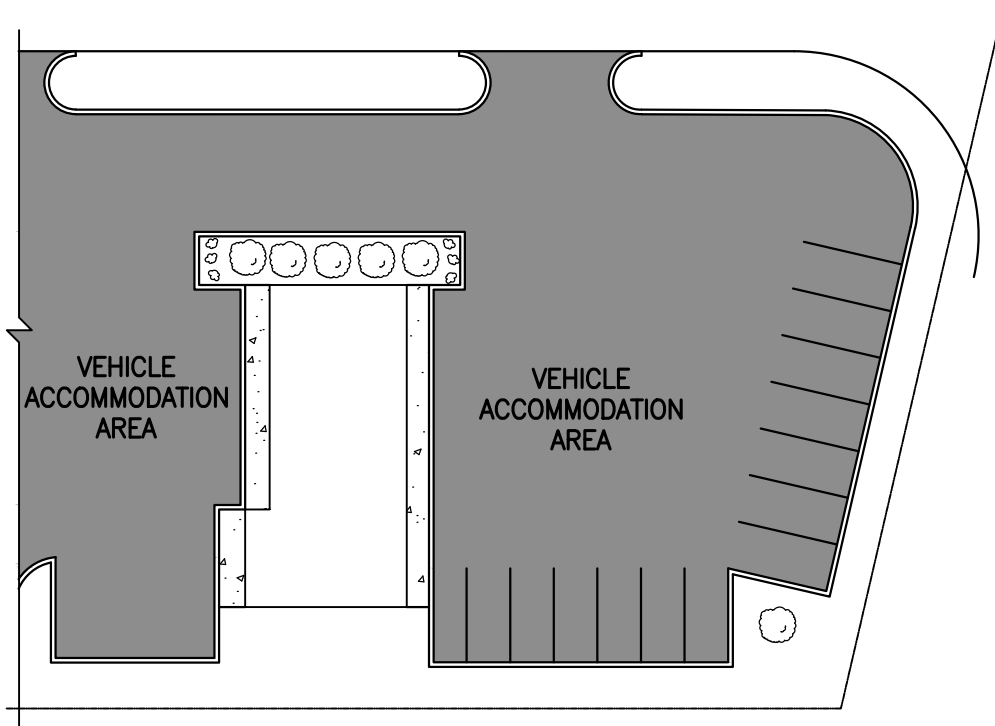

TYPICAL VEHICLE ACCOMMODATION  
AREA SURFACES

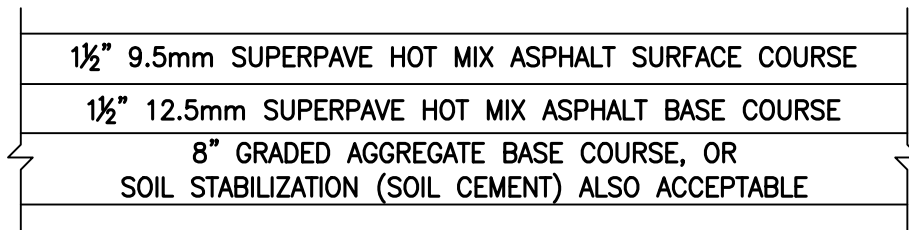

PAVED SURFACE SECTION



ALTERNATE - GRAVEL SURFACE SECTION

G:\Projects\2020\200110 Town of Denton On-Call Services 2020-2025\Standards & Specs\Revised 2021 (CMB)\Manual\DETAILS\CAD\PAVEMENT & CONCRETE.dwg May 04, 2021 - 3:26pm

<p align="center">TOWN OF DENTON DEPARTMENT OF PUBLIC WORKS</p>			PAVEMENT & CONCRTE DETAILS	REVISED	SHEET
			VEHICLE ACCOMMODATION	DEC 2007	PW-9.00
			AREA SURFACES		