

**TOWN OF DENTON**  
**ROAD OPENING & DIRECTIONAL DRILLING PERMIT APPLICATION**

Fax to: **Planning & Codes**                      Date: \_\_\_\_\_                      From: \_\_\_\_\_  
Attn: **David Renshaw**  
Email: **drenshaw@dentonmaryland.com**  
Fax #: **410-479-3534**                                      Company: \_\_\_\_\_  
Phone#: **410-479-3625**                                      Fax #: \_\_\_\_\_                                      Phone#: \_\_\_\_\_

Location of Work: \_\_\_\_\_

Description & Purpose of Work: \_\_\_\_\_

Emergency: Yes  No  Starting Date: \_\_\_\_\_ Completion Date: \_\_\_\_\_

Estimated Opening Area: \_\_\_\_\_ Sq.yds                      Is Opening within a Street Intersection? \*Yes  No

Will opening and/or drilling work, equipment, or materials interfere with a Traffic Lane? \*Yes  No   
*\*If Yes, applicant must submit a Maintenance of Traffic plan for review and approval prior to work commencement.*

Provide sketch below of proposed openings and/or drillings including street names, curb line or edge of paving:

MULTIPLE OPENINGS MAY BE INCLUDED ON ONE PERMIT, ONLY IF LOCATED IN SAME BLOCK. *No work shall be performed (except in emergency) before this application is approved and permit granted. A copy of the permit shall be available on site when work is in progress. Applicant agrees to restore road according to town specifications within fifteen (15) days from date work is completed. Applicant must notify this department by phone in emergency situations before proceeding with work.*

Signature of person authorized to make application: \_\_\_\_\_ Date: \_\_\_\_\_

Date permit approved: \_\_\_\_\_ By: \_\_\_\_\_ Bond required? Yes  No

Special conditions or instructions: \_\_\_\_\_  
\_\_\_\_\_  
\_\_\_\_\_

Final completion inspection date: \_\_\_\_\_ By: \_\_\_\_\_

Accepted                       Rejection                       Reason: \_\_\_\_\_  
\_\_\_\_\_  
\_\_\_\_\_

G:\Projects\2020\200110 Town of Denton On-Call Services 2020-2025\Standards & Specs\Revised 2021 (CHB)\Manual\DETAILS\CAD\PAVEMENT & CONCRETE.dwg May 04, 2021 - 3:26pm

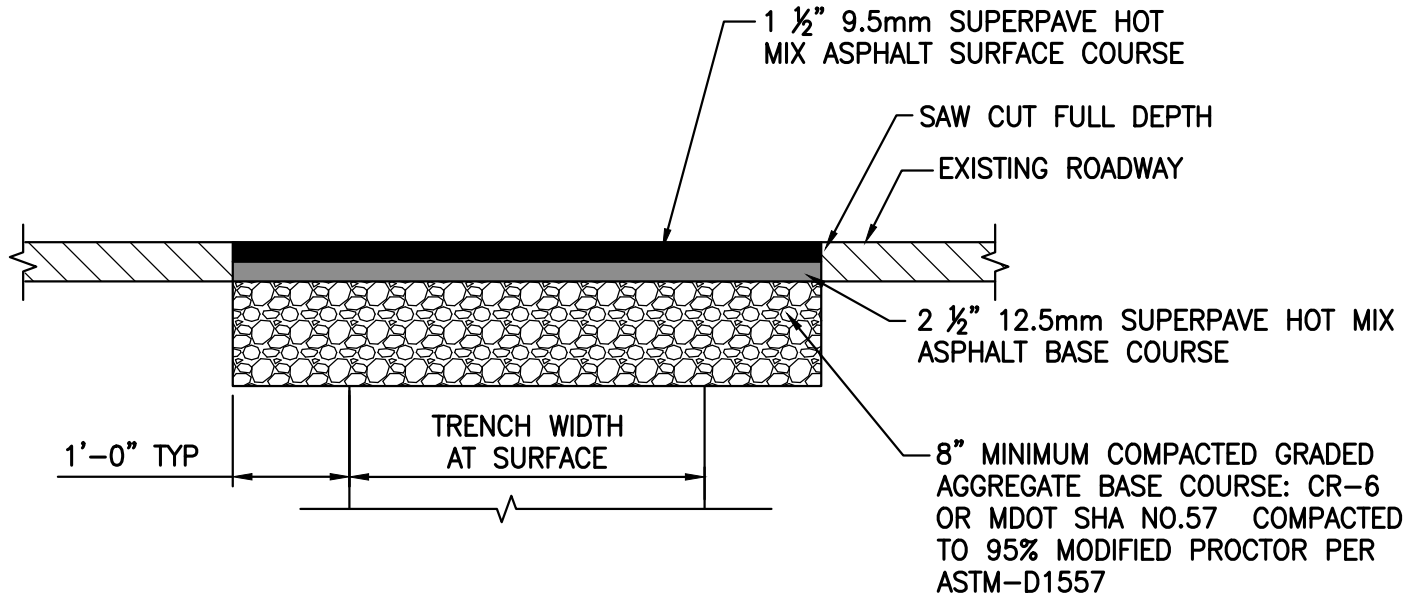

PAVEMENT RESTORATION DETAIL

<p>TOWN OF DENTON DEPARTMENT OF PUBLIC WORKS</p>		<p>DENTON PUBLIC WORKS</p>	PAVEMENT & CONCRTE DETAILS		REVISED	SHEET
			PAVEMENT RESTORATION		DEC 2007	
					APR 2021	
					PW-7.00	